

SERIES 211.40

SELF-PRIMING VERTICAL SCREW PUMP FOR NON LUBRICATING LIQUIDS

PRODUCTS

WATER

SEAWATER

OILS

HEAVY FUEL OILS

LIGHT PRODUCTS

LABELLING

CARGO PUMPS

TRANSFER PUMPS

CIRCULATION PUMPS

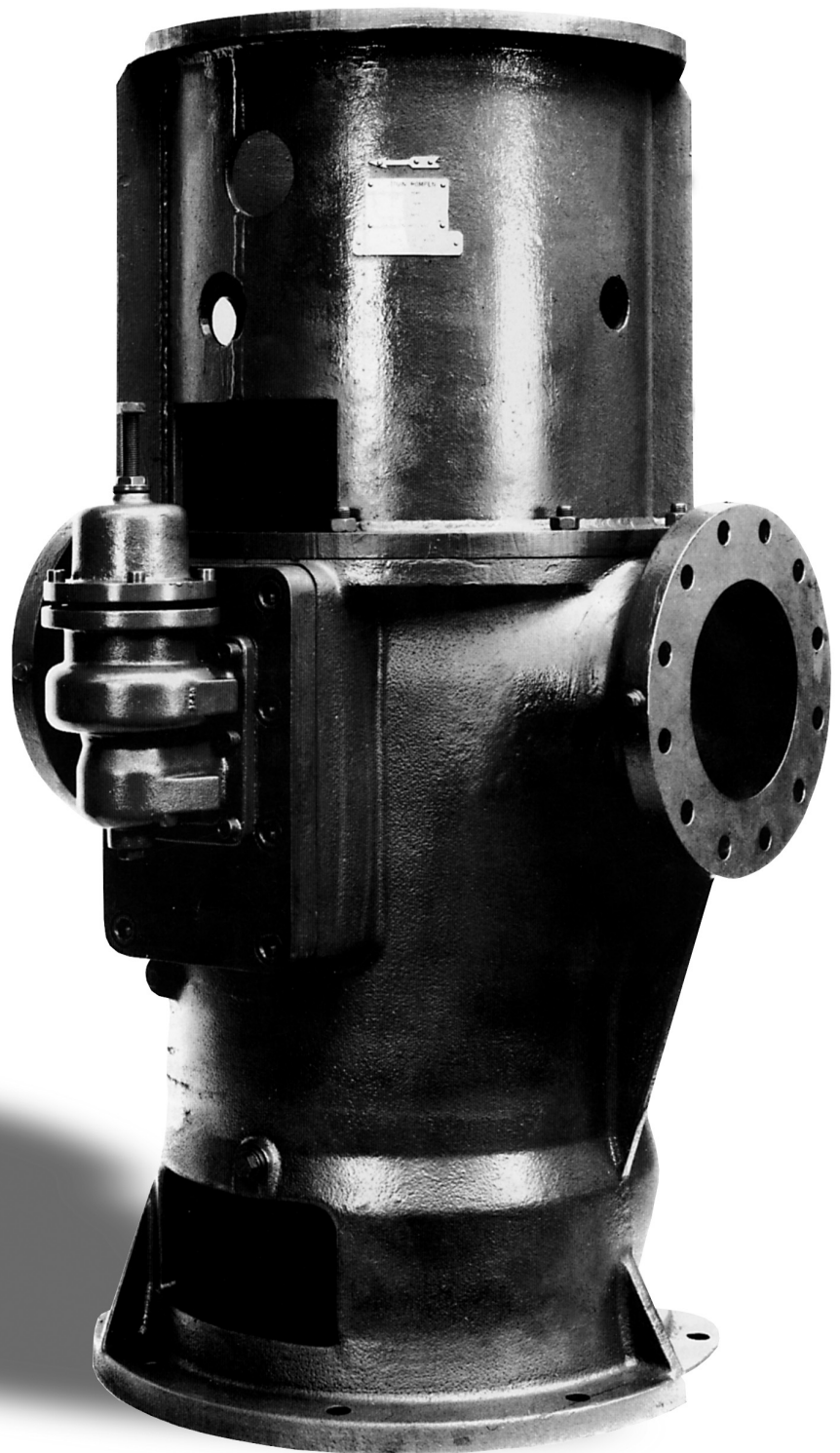

A COLFAX BUSINESS UNIT



HOUTTUIN B.V.



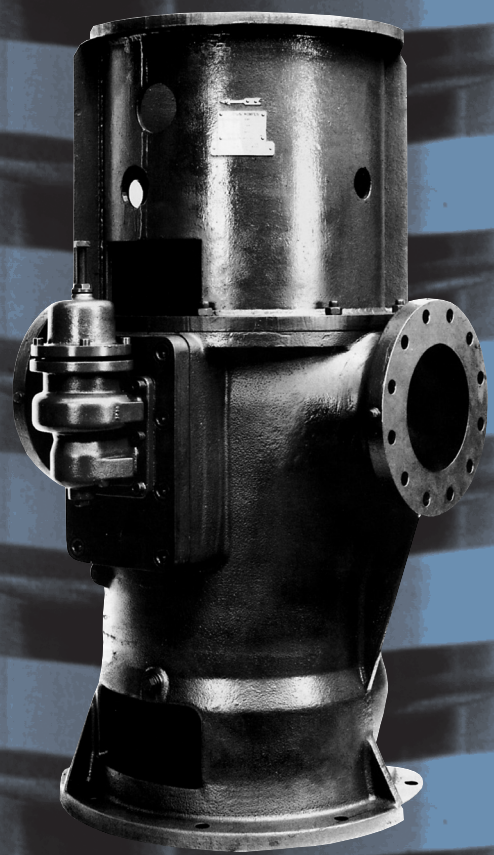

Principle

The Houttuin double entry twin screw pumps series 211 are vertical rotating self priming positive displacement pumps. Two inter-meshing screws rotating in a pump casing insert ensure high pumping efficiency with constant axial flow and unequalled suction power.

Construction

The spindles are supported and axially held in position by ball bearings. The transmission of torque from the driven spindle to the idler spindle is effected by oil lubricated timing gears located outside of the pumping area in an attached gear box. The ball bearings and timing gears maintain a small clearance between the screws, thus preventing metal to metal contact.

Shaft sealing

Single unbalanced mechanical seals keeping the liquid to be pumped isolated from the bearings and the gear box.

Overload protection

For protection against overload a built-on spring loaded relief valve can be supplied

Applications

For pumping contaminated or slightly abrasive, lubricating and non-lubricating liquids of low or high viscosity which do not chemically attack the pump materials (corrosion proof materials can be offered). In the chemical and petrochemical industry, soap and grease industry, paint and lacquer industry, food and beverage industry, plastics industry, sugar industry, environmental technology, in tankfarms and in the shipbuilding industry.

Products

- Water
- Seawater
- Oils
- Heavy fuel oils
- Light products

Labelling

- Bilge/ballast pumps
- General service pumps
- Cargo pumps
- Transfer pumps

Performance data

Capacity	Q	up to 1100 m ³ /h
Viscosity range	V	0,6 to 1500 cSt
Temperature of pumped liquid	t	up to 100 °C
Inlet pressure	p _s	up to 10 bar
Outlet pressure	p _d	up to 16 bar
Difference pressure	Δp	up to 16 bar
Speed	n	up to 2900 rpm
Flanges		according to DIN or ANSI

A preliminary pump selection can be effected by means of the performance graphs. For the exact performance data as function of the viscosity of the liquid to be pumped and the pump speed, please refer to the individual characteristics.

AVAILABLE MATERIALS

FOR PUMP AND MECHANICAL SEALS:

Pump				Mechanical seal according to DIN 24960 / API		
Screw shafts	Casing insert	Casing	Covers	Seal faces	Springs	'O' -rings
- Carbon Steel	- Cast Iron	- Cast Iron	- Cast Iron	- Chrome Steel or	- Stainless	- Viton
- Stainless Steel	- Nodular	- Nodular	- Cast Iron	- Silicon Carbide	Steel	- Teflon
(Type 400)	Cast Iron	Cast Iron	with coating	against	(Type 300)	
- Stainless Steel	- Ni-Resist	- Ni-Resist	- Nodular	- Carbon		
(Type 300)	- Bronze	- Cast Iron	- Carbon Steel			
		with coating	- Stainless Steel			
		- Bronze				
		- Carbon Steel				
		- Stainless Steel				

Flow rate/pressure at minimum and maximum viscosity according to pump size.
 For exact performance data dependant of viscosity and rpm please refer to the individual characteristics per pump size.

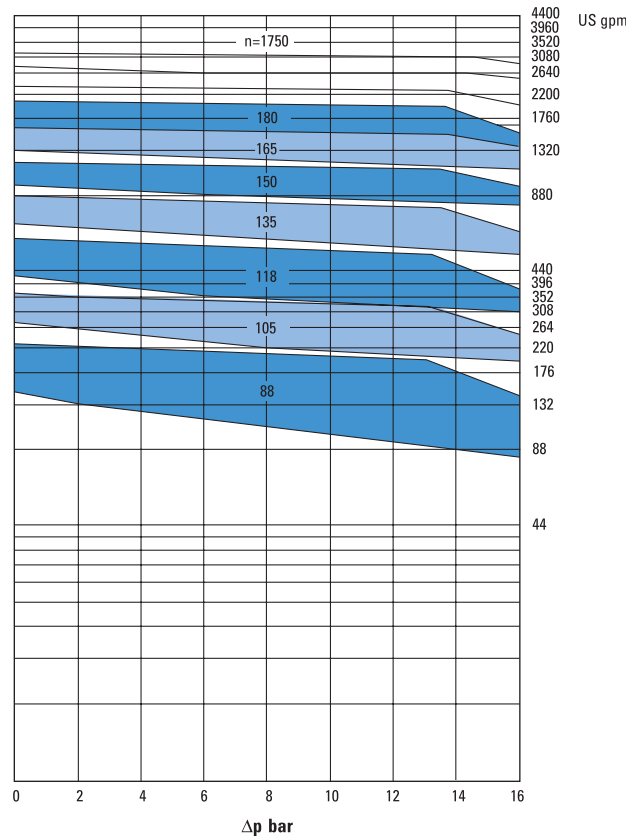
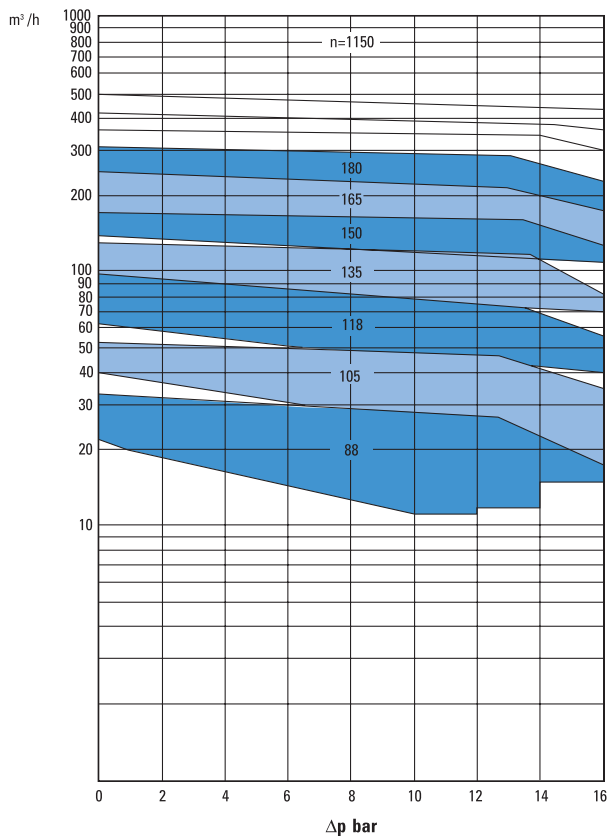
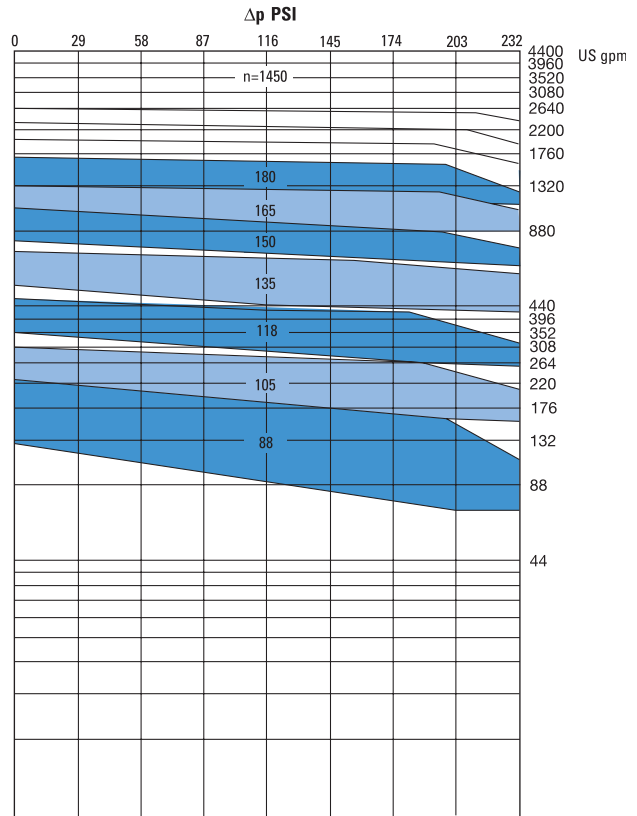
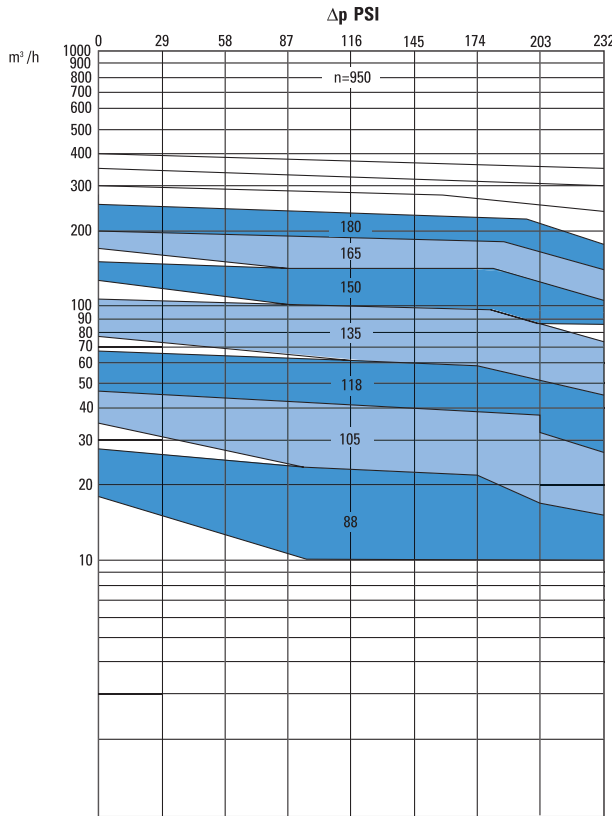

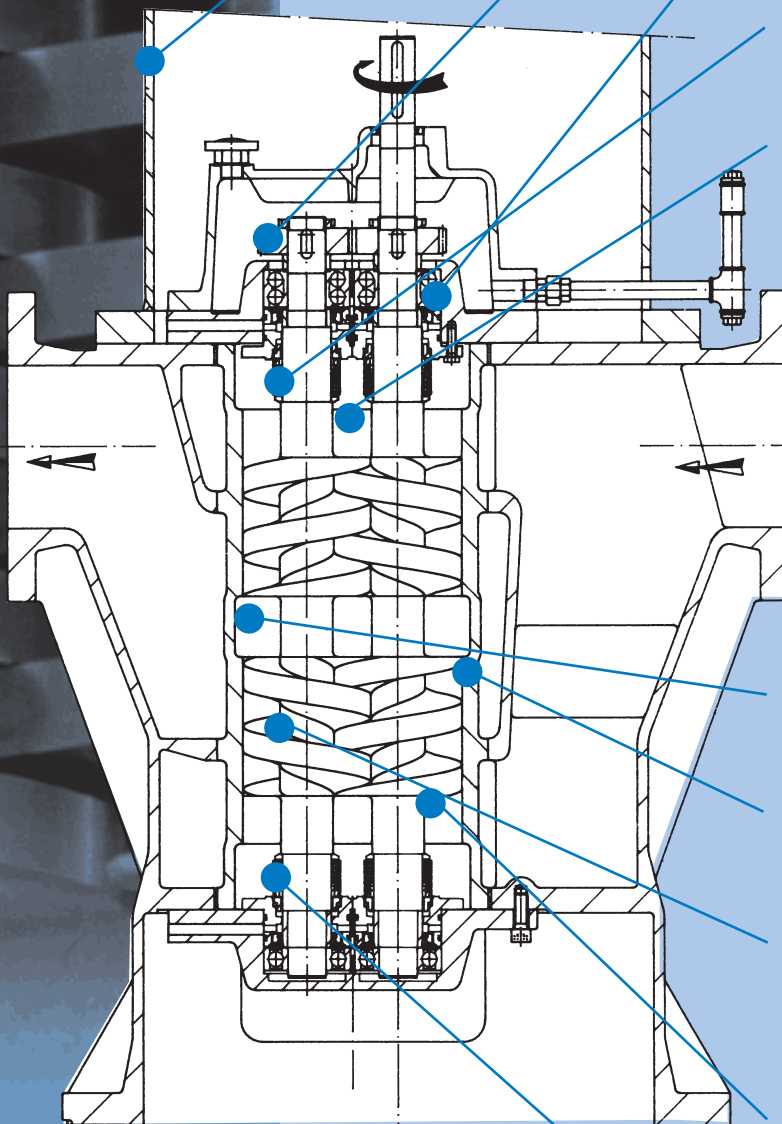

Drive by **commercial standard motors**, construction V1, all types of enclosure possible, therefore a motor bracket is optional.

Safe transmission of torque through the hardened and ground oil lubricated timing gears

Amplly dimensioned oil lubricated and **maintenance free ball bearings**, which additionally serve for the axial location of the spindles.

Safe shaft sealing by single unbalanced and product lubricated mechanical seals.

For **over load protection** a direct mounted pressure relief valve is optional

Axial forces balanced through double entry spindles

Interchangeable casing insert therefore different materials possible.

Rigid spindles of solid material therefore compared with multi-part spindles **no crevice corrosion**.

The special profile of the spindle flanks results in **continuously and nearly pulsation-free pumping, high efficiency, good NPSH-values and constant pressure course**.

In standard design the pump is fitted with single unbalanced mechanical seals, **if required with fluid chamber for flushing or quenching**.

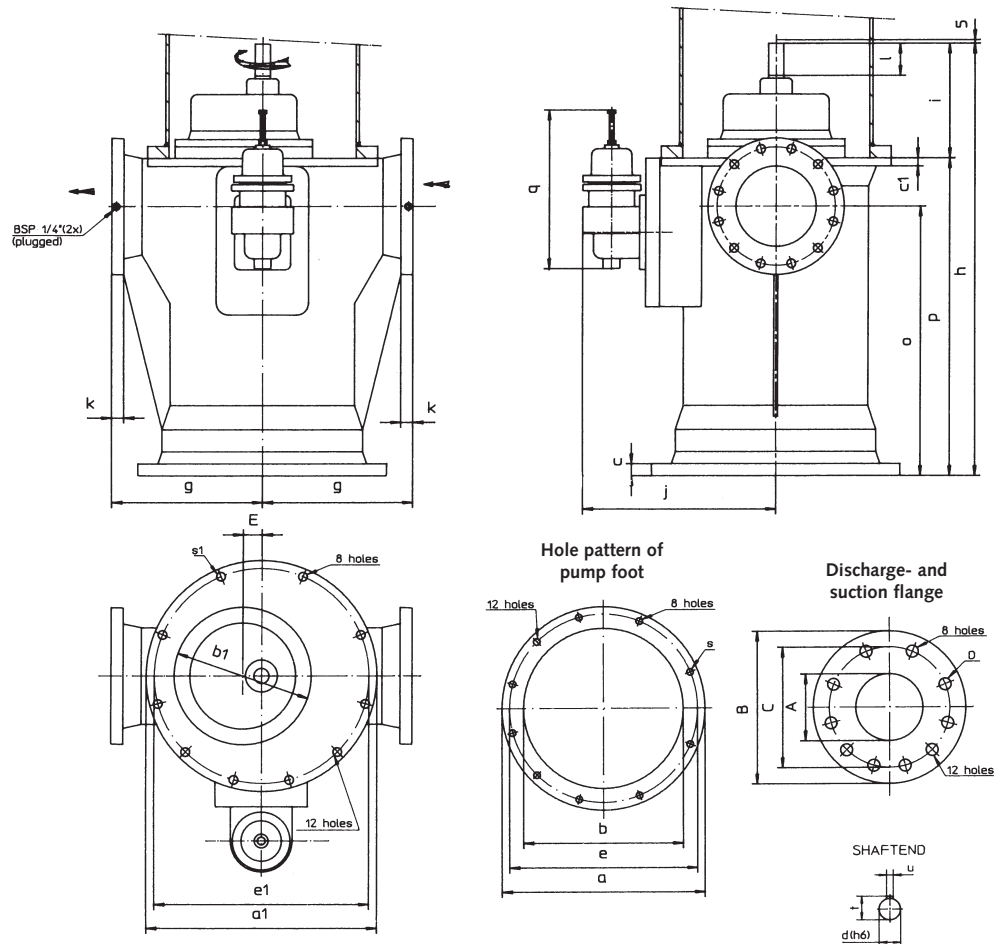

Sense of rotation: clockwise seen from drive side

PUMP SIZE	FLANGES PN16 DIN 2533					PUMP FOOT					PUMP UPSIDE				
	A	B	C	D	E	a	b	c	e	s	a1	b1	c1	e1	s1
88	100	228	180	8x18	32,5	500	380	26	460	8x18	450	277	22	420	8xM12
105	125	254	210	8x18	37,5	530	400	30	490	8x18	490	290	22	450	8xM16
118	150	285	240	8x22	42	610	470	30	560	8x22	575	340	24	535	8xM16
135	200	343	295	12x22	47	620	475	30	570	8x22	575	340	25	535	8xM16
150	250	405	355	12x26	52,5	660	510	30	610	12x22	620	390	28	580	8xM16
165	250	405	355	12x26	57,5	700	550	30	650	12x22	660	415	30	620	12xM16
180	300	460	410	12x26	63	750	600	30	700	12x22	720	452	30	670	12xM16

PUMP SIZE	PUMP DIMENSIONS								SHAFT END				RELIEF VALVE SIZE	WEIGHT KG (CA)
	g	h	i	j	k	o	p	q	d	l	t	u		
88	300	932	310	362	24	555	622	270	28	60	31	8	46	295
105	330	992,5	322,5	382	26	590	670	270	28	60	31	8	46	310
118	360	1060	340	460	26	625	720	397	32	80	35	10	70	380
135	375	1140	350	535	30	670	790	397	38	80	41	10	70	405
150	395	1300	400	568	32	750	900	540	42	110	45	12	100	515
165	420	1409	429	588	32	830	980	540	45	110	48,5	14	100	660
180	450	1492	445	615	32	875	1047	735	50	110	53,5	14	135	895

dimensions in mm, dimensions are subject to alternations.

*) The diagrams show the performance range of the different pump series in our pump program and are for information only.

STANDARD PUMPS

With Internal Bearings

for lubricating liquids

viscosity range : 20 - 760 cSt
: 98 - 3500 SSU

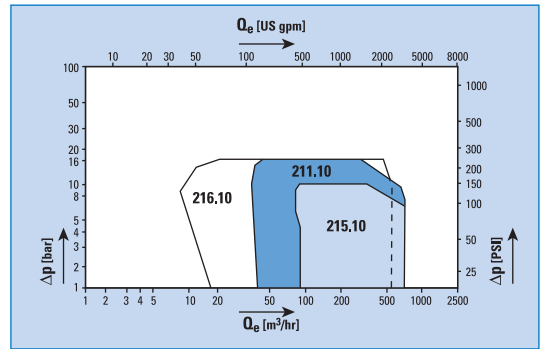

With External Bearings

for non-lubricating liquids

viscosity range : 0,6 - 1500 cSt
: 32 - 7000 SSU

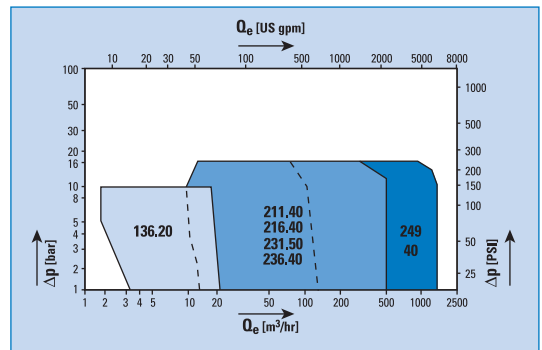

With External Bearings

for lubricating and non-lubricating liquids

viscosity range : 0,6 - 100.000 cSt
: 32 - 466.000 SSU

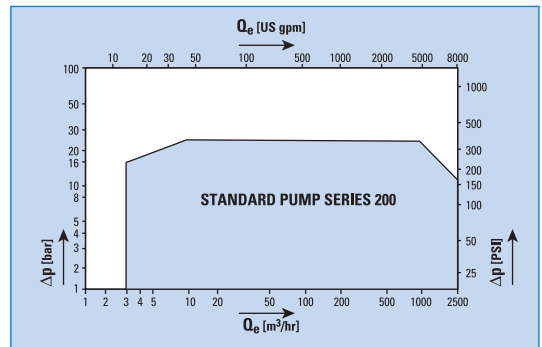

ENGINEERED PUMPS

With External Bearings

for lubricating and non-lubricating liquids

viscosity range : 0,6 - 100.000 cSt
: 32 - 466.000 SSU

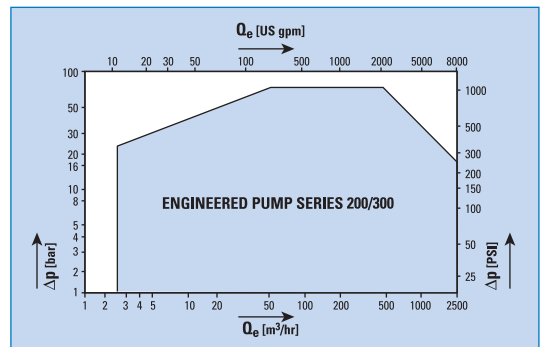

HOUTTUIN B.V.

Sophialaan 4, 3542 AR Utrecht
The Netherlands
P.O. Box 76, 3500 AB Utrecht
The Netherlands
Phone +31 - (0)30 - 2484611
Telefax +31 - (0)30 - 2411845
Telex 47280
Internet <http://www.houttuin.nl>