

# Operating and Maintenance Instructions

VM No.: 467.0003 GB

Edition: 11.00

Ident No.: 550 246

## ALLMARINE

### Series MI and MA

**Retain  
for future  
use!**

Order No.:

Pump Ident. No.:

Machine No.:

Pump Type:

Operating data, dimensions and other additional information can be found in the order-specific part of the documentation.



These Operating and Maintenance Instructions contain information from the pump manufacturer. They may need to be supplemented by instructions of the operator company for its personnel. These instructions do not take account of specific information relating to operation and maintenance of the process plant into which the pump is integrated. Such information can only be given by the persons responsible for construction and planning of the plant (plant manufacturer).

**Such specific instructions relating to operation and maintenance of the process plant into which the pump is integrated have priority over the instructions of the pump manufacturer. The plant manufacturer must on principle observe the limits of use!**

**Refer to the operating instructions of the plant manufacturer!**

## Contents

1. General
2. Safety
3. Transportation and Intermediate Storage
4. Description
5. Installation/Mounting
6. Start-up/Shutdown
7. Maintenance/Repair
8. Operating Faults, Causes and Remedial Action
9. Associated Documentation

### Important note:

This operating manual is to be supplemented by the order-related informations.

## 1 General

### 1.1 Pump designation

The exact designation can be found in the order-specific documents (see data sheet).

### 1.2 Proper use

Information on proper use of the pumps is provided in the technical data sheet.

The pumped liquid must not contain any abrasive constituents nor corrode the pump materials.

### 1.3 Types of construction

The pumps are supplied in various designs, differing mainly in the shaft seals and the materials.

### 1.4 Performance data

The exact performance data can be taken from the order data sheet and/or acceptance test report.

### 1.5 Warranty

Our warranty for shortcomings in the supply is laid down in our delivery conditions. No liability will be undertaken for damages caused by non-compliance with the operating instructions and service conditions.

If at any later date the operating conditions change (e.g. different fluid conveyed, speed, viscosity, temperature or supply conditions), it must be checked by us from case to case and confirmed, if necessary, that the pump is suited for those purposes. Where no special agreements were made, pumps supplied by us may, during the warranty period, only be opened or varied by us or our authorized contract service workshops; otherwise our liability for any defects will cease.

### 1.6 Testing

Prior to leaving our factory, all pumps are subjected to a leak and pressure test. Additional tests will only be performed on request.

### 1.7 Availability

As a matter of principle, we recommend stocking replacement pumps and withdrawable units (hydraulic action system) where the supplied pumps are a decisive factor in maintaining a production or delivery process. In this way downtimes can be avoided, or reduced to a minimum.

### 1.8 Pressure limit



The sum of inlet pressure and maximum delivery pressure must not be greater than the permissible internal pump pressure (see data sheet).

## 2 Safety

These operating instructions contain basic safety instructions for installation, operation and maintenance. It is therefore essential that they are read by fitters and all specialist staff and customer personnel prior to installation and start-up. They must always be kept at hand at the place of installation.

The special safety instructions contained in the other chapters must be observed in addition to the general safety instructions in this chapter.

### 2.1 Identification of safety instructions in the operating manual

The safety instructions contained in these operating instructions which represent a danger to personnel if not complied with are specially marked by the general danger symbol:



Warning symbol as per DIN 4844–W9

Warning of danger from electric voltage is indicated as follows:

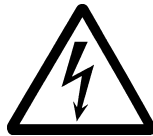

Warning symbol as per DIN 4844–W8.

Instructions which are essential to avoid endangering the machine and its operation are marked by the word

**ATTENTION**

Instructions affixed directly to the machine such as

- Directional markers
- Signs for fluid connections

must always be observed and maintained in fully legible condition at all times.

### 2.2 Personnel qualification and training

The operating, maintenance, inspection and mounting personnel must be appropriately qualified for the duties assigned to them. The scope of their responsibilities, competency and supervisory duties must be closely controlled by the customer. If the personnel do not have the required knowledge, they must be trained and instructed. If required, this may be provided by the manufacturer/supplier on behalf of the customer. The customer must additionally ensure that personnel fully understand the content of the operating instructions.

### 2.3 Dangers in the event of non-compliance with safety instructions

Failure to comply with the safety instructions may result in danger to persons, and place the environment and the machine at risk. Non-compliance with the safety instructions will lead to the loss of any claims for damages.

Non-compliance may result in the following dangers:

- Failure of important functions of the plant
- Failure of specified methods for maintenance and servicing
- Danger to persons resulting from electrical, mechanical and chemical effects
- Danger to the environment resulting from leakage of hazardous substances

### 2.4 Responsible working practices

The safety instructions contained in these operating instructions, current national accident prevention regulations, as well as internal working, operating and safety rules of the customer, must be observed.

### 2.5 Safety instructions for the user/operator

- Hot or cold machine parts representing a danger must be protected against accidental contact on site.
- Protection against accidental contact for moving parts (such as the coupling) must not be removed while the machine is in operation.
- When operating pump aggregates in a dust-laden environment (e.g. milling, chipboard manufacture, bakeries), the surfaces of the pumps and motors must be cleaned at regular intervals, depending on local conditions, in order to maintain the cooling effect and eliminate the possibility of spontaneous combustion. Please also see explosion protection regulations (ZH 1/10).
- Leakage (e.g. from the shaft seal) of hazardous substances being handled, such as explosive, toxic or hot materials, must be discharged in such a way that no danger to persons or the environment is created. Legal regulations must be observed.
- Dangers from electrical energy must be eliminated. For details in this regard, please refer to VDE and local power company regulations.

**2.6 Safety instructions for maintenance, inspection and installation**

The operating company must ensure that all maintenance, inspection and installation tasks are performed by authorized and qualified specialist personnel who have thoroughly studied the operating instructions.

Work on the machine is only to be carried out when the machine is at a standstill. The procedure for shutting down the machine described in the operating instructions must always be followed.

Pumps or aggregates handling fluids which are detrimental to health must be decontaminated. All safety and protective devices must immediately be refitted and made operational on completion of the work.

The instructions under Section 6.1, "Preparation for start-up", must be observed before restarting.

**2.7 Unauthorized conversion and production of replacement parts**

Conversion or modification of the machines is only permissible after consultation with the manufacturer. Original replacement parts and accessories approved by the manufacturer are intrinsic to safe operation. If other parts are used the manufacturer cannot be held liable for the consequences.

**2.8 Unacceptable modes of operation**

The operational safety of the machine supplied is only ensured when it is used in accordance with *Section 1* of the operating instructions. The limit values given on the data sheet must not be exceeded under any circumstances.

**3 Transportation and Intermediate Storage**

**3.1 Packaging**

Attention must be paid to the figurative markings on the packaging.

The suction and pressure side and all auxiliary connections must always be closed during transportation and storage.

**ATTENTION** The coverings must only be removed immediately before connecting the pipeline.

**3.2 Transportation**

The pump or pump aggregate is to be safely transported to the place of installation, if required by means of lifting gear.

 **The regulations for lifting loads in accordance with VBG 9a must be observed. Crane and sling equipment must be adequately dimensioned. Sling equipment must not be secured to the lifting eyes of the motor, except as additional protection against overturning in the event of nose-heaviness.**

**Transportation to the installation site**

 Make sure that the unit is transported in a horizontal position and that it cannot slip out of the transport safety equipment.

Figure 3.1



**Transportation at the installation site**

 Make sure that the unit is transported safely. Overturning due to nose-heaviness must be prevented.

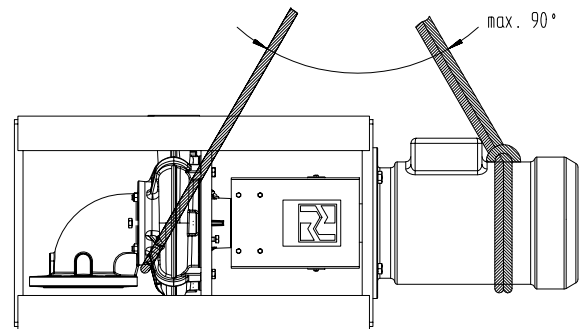
Figure 3.2



**Transport damage**

**ATTENTION** Check the pump for damage on receipt. Any damage detected must be notified immediately.

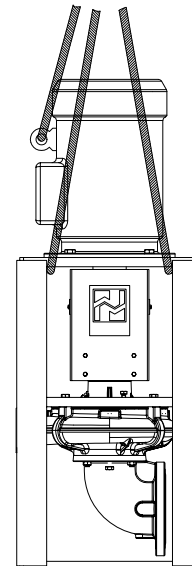
### 3.3 Preservation / Storage of centrifugal pumps

#### 3.3.1 Preservation

In the case of storage or prolonged standstill, the pumps must be protected against corrosion. In those cases, an outside and inside preservation is to be provided. The durability of the protection against corrosion, which is limited in time, depends on the composition of the preservative to be applied and the storage conditions.

**ATTENTION** Under normal circumstances the pumps have no special preservative.

At an additional charge we can, however, supply pumps and replacement parts ex factory with a preservative adequate to the planned storage period.

##### 3.3.1.1 Outside preservation

The outside preservative should be applied by painting or spraying with a spray gun.

##### Points of preservation:

All bright and unvarnished parts (e.g. shaft ends, couplings, flange facings, valve and manometer connections).

##### 3.3.1.2 Inside preservation

(Not required for pumps made of stainless materials.)

Internal preservation is applied by painting, spraying using spray guns, filling/dipping and subsequent draining. Finally, the suction and outlet branches as well as all other supply and discharge branches must be sealed with dummy flanges or dummy plugs (plastic caps).

##### Points of preservation:

All bright parts inside the pump (e.g. pump casing inside, bearing bracket, shafts, impellers and diffusers).

##### 3.3.1.3 Storage times

Depending on the required storage period and the surroundings, we recommend the use of preservatives from Valvoline GmbH, Hamburg.

#### Storage in a closed, dry and dust-free room

Storage time	up to 6 months	up to 12 months	over 12 months ①
Internal preservation	Tectyl 511 M	Tectyl 511 M	Tectyl 506 EH
External preservation	Tectyl 511 M	Tectyl 511 M	Tectyl 506 EH

#### Storage in the open-air, central European climate

Storage time	up to 6 months	up to 12 months	over 12 months
Internal preservation	Tectyl 542	Tectyl 542	Tectyl 506 EH
External preservation	Tectyl 542	Tectyl 506 EH	Tectyl 506 EH

#### Storage in the open-air, tropical climate, aggressive industrial air or proximity to the sea

Storage time	up to 6 months	up to 12 months	over 12 months ③
Internal preservation	Tectyl 542	Tectyl 542	Tectyl 506 EH
External preservation	Tectyl 506 EH	Tectyl 506 EH	Tectyl 506 EH

① Internal and external preservation must be renewed after 48 months at the latest.

② External preservation must be renewed after 18 months at the latest. Internal preservation must be renewed after 48 months at the latest.

③ External preservation must be renewed after 12 months at the latest. Internal preservation must be renewed after 48 months at the latest.

**Note:** The preservatives listed are to be regarded as a recommendation. Alternatively, technically equivalent products from other manufacturers can be used.

When handling preservatives, the safety hints contained in the relevant DIN safety data sheets and those of the manufacturer must be complied with.



##### 3.3.1.4 Depreservation

Prior to setting the pump in motion, the inside preservation must be removed.



**Environmentally compatible disposal must be ensured.**

Preservatives can be removed with wax solvents, petroleum ether, diesel, petroleum or alkaline cleaners. However, the simplest method is to use a steam cleaner.

**Recommendation for Tectyl 506 EH:** Allow petroleum ether to act for 10 minutes before any further action.



Pumps that are used in the food or drinking water sector must be dismantled and thoroughly cleaned prior to depreservation.

A suitable solvent that is compatible with the liquid to be pumped (drinking water/food) can be used as the cleaning agent, e.g. Spiritus, Ritzol 155 or suds with a high alkaline content. Steam cleaning is ideal.

**ATTENTION** After a prolonged storage period (more than 6 months), all elastomers (O-rings, shaft seals) must be checked for elasticity of shape. Embrittled elastomers must be replaced. EP rubber elastomers (EPDM) must be replaced on principle.

##### 3.3.2 Storage

During storage of the pump, the suction and outlet branches and all other supply and discharge branches must always be closed with dummy flanges or dummy plugs.

Storage should be in a dry, dust-free room. During storage, the pump should be cranked at least once a month. During this process, parts such as the shaft and bearings should change their position.

##### 3.3.3 Monitoring of preservation

The preservation must be checked at regular intervals. The preserved areas must be inspected every 6 months and re-treated, if necessary.

**ATTENTION** We cannot accept any liability for defects that arise due to incorrect preservation treatment.

**4 Description / Principle design of the pump**

The pictorial presentation may not correspond with the pump supplied.  
The actual design will be stated in the specific order documents.

**4.1 Design with radially inlet, Series MI**

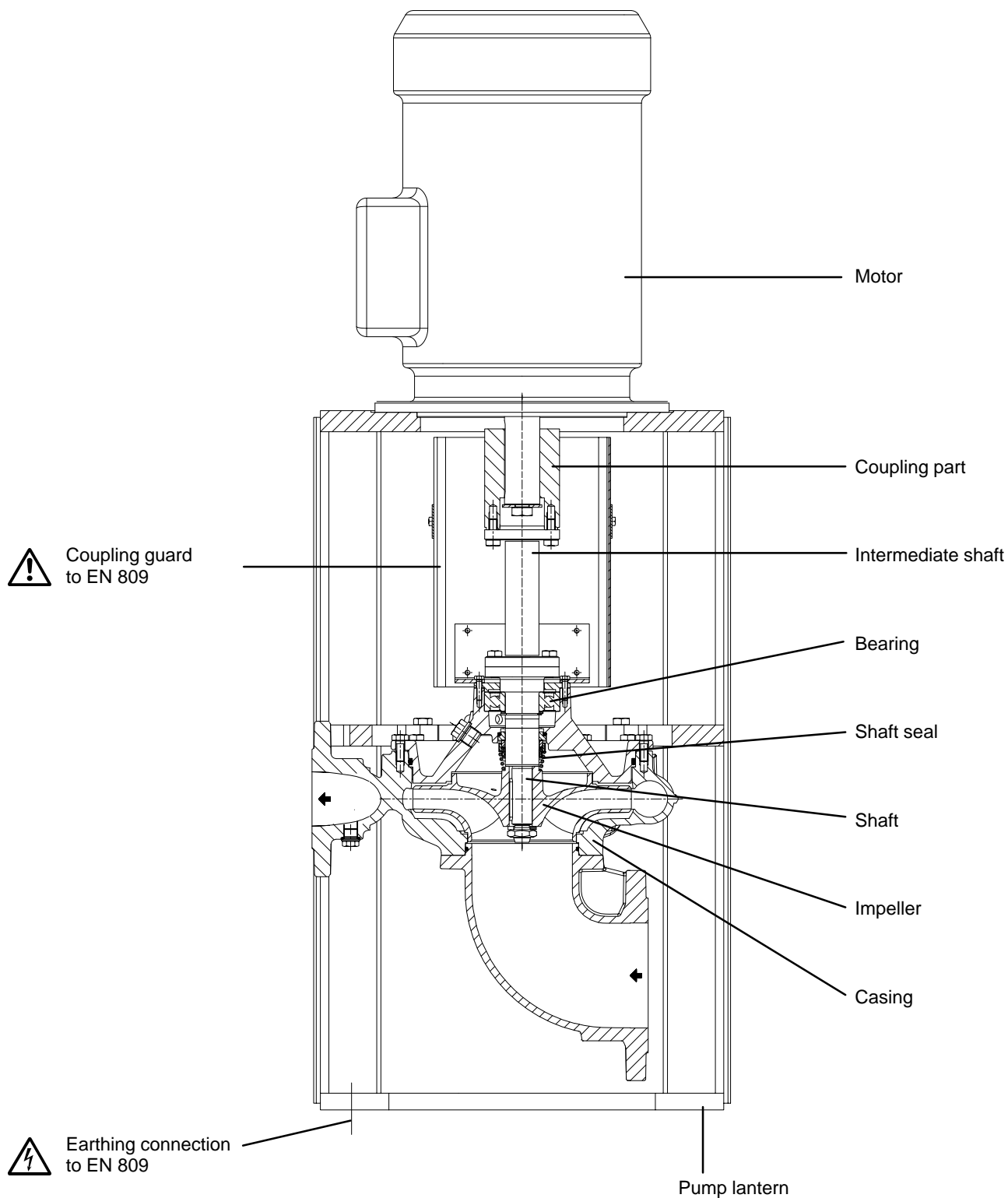

4.2 Design with axially inlet, Series MA

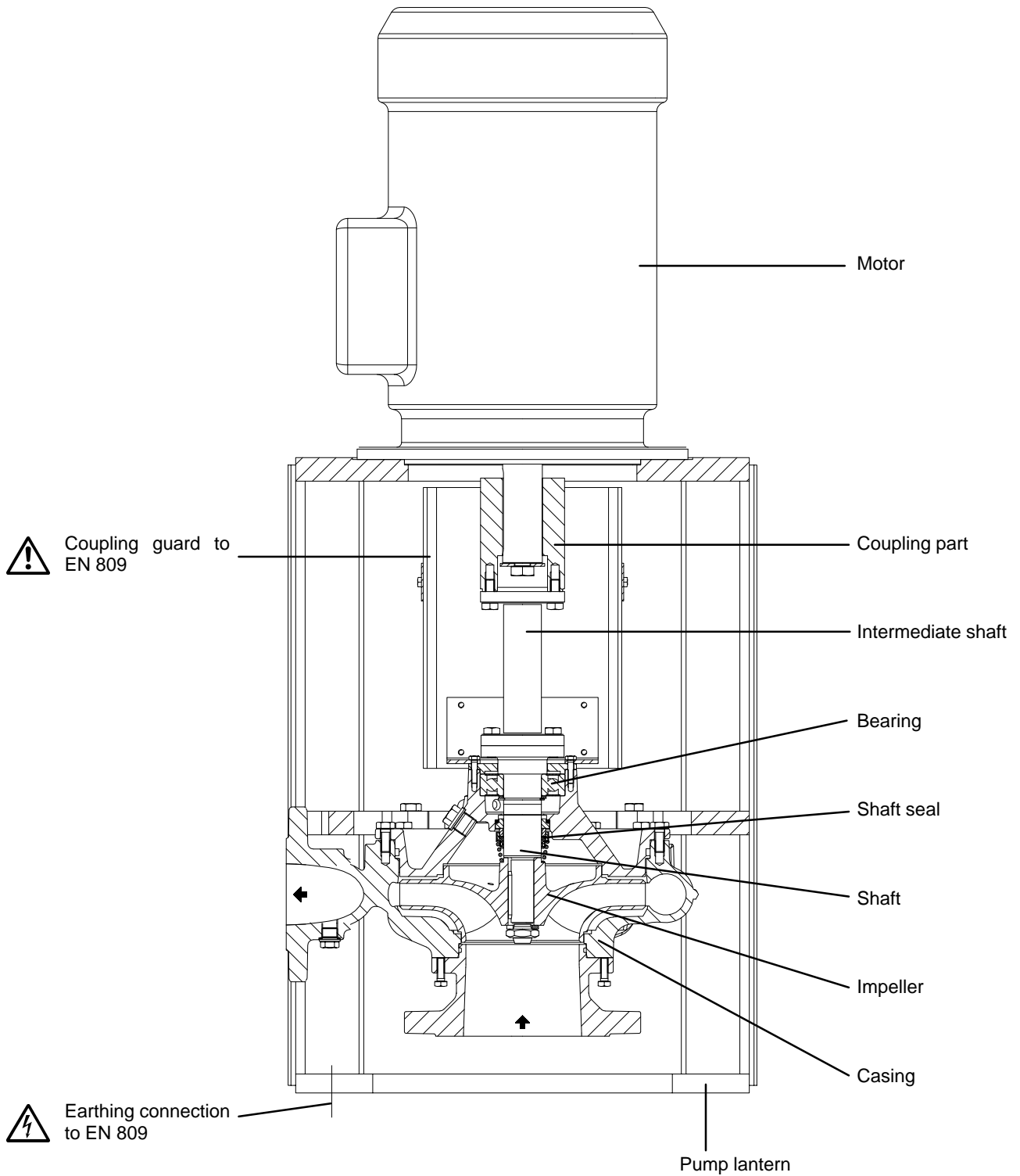

## 5 Installation/Mounting

### 5.1 Installation

For installation methods and locations, please see installation drawing.



**Other methods of installation are not permissible without prior consultation with the manufacturer.**

#### 5.1.1 Place of installation

Temperature: min. -20 °C  
max. +40 °C

relative air humidity:  
permanent max. 85 %  
temporary max. 100 %

Installation height: max. 1000 m above NN

For data differing from this, please consult the manufacturer.

**ATTENTION** Intensive vibrations in the vicinity of the pump unit can lead to bearing damage and must therefore be avoided.

**ATTENTION** Pumps used for the delivery of water must be installed so that they are protected against freezing.

#### 5.1.2 Protective devices



In order to prevent injuries due to burns, at pumping liquid temperatures higher than 60 °C protective devices in accordance with EN 809 must be provided on site.

#### Heat insulation

**ATTENTION** Only the volute housing may be insulated with heat insulating material. In order to enable optimum heat dissipation no other pump components may be insulated.

### 5.2 Foundation

#### 5.2.1 General

The foundation may be a floor/concrete base or a load-bearing steel foundation frame.

**ATTENTION** The foundations must be constructed in such a way that they can take the weight of the pump unit and all operating forces that occur.

#### 5.2.2 Characteristics of a steel foundation frame

A steel foundation frame must be constructed in such a way that the pump lantern is supported evenly and can be secured with screw fixings.

#### 5.2.3 Characteristics of a floor/concrete foundation

The foundation must be horizontal, flat and clean, and be capable of bearing the full load upon it.

**Note:** Concrete foundations must be executed with standard concrete of strength class B 25 as a minimum.

### 5.3 Alignment of the pump aggregate

The pump aggregate must be aligned to its pre-set height and system dimensions. This is done using suitable steel shims, arranged directly adjacent to each fixing bolt.

The overall height of the steel shims is determined by the established system dimensions of the plant. The steel shims and the pump lantern must be positioned evenly and securely.

Horizontal alignment of the aggregate is produced by way of flat-machined surfaces on the pump using a machine spirit level. Measurements are taken in longitudinal and transverse directions of the pump aggregate.

**Permissible deviation:** max. 1 mm per 1 m length.

#### 5.3.1 Fixing the pump aggregate

In order to prevent deformation of the pump lantern, this must first of all be screwed tightly at three points. Before tightening the fourth screw, spacers should again be positioned around the screw, in order to balance out the unevenness of the seating.

**ATTENTION** The prescribed tightening torque (Section 7.2.3) must be observed.

Precise details on the shape and dimension of the fixing are provided in the installation drawing.

#### 5.3.2 Checking the alignment

After aligning and tightening the screws, it must be possible to turn the pump and drive by hand, without any strain.

**Note:** The pump unit should not be welded to the base for technical installation reasons.

### 5.4 Assembly of pump and drive motor

If the aggregate is only assembled at the place of use, the intermediate shaft is assembled as follows:

1. Coat the motor shaft end with a fine film of molybdenum disulfide (e.g. Molykote) and insert key.

2. Push the coupling part onto the motor shaft end and fix the disc.

**ATTENTION** The possibility of shock and stress on the pump and drive motor components must be eliminated.

3. Mount the intermediate shaft and tighten the screws.

4. Mount the contact protection.



According to accident prevention regulations, the pump must only be operated with a protection against accidental contact.

### 5.5 Raumbedarf für Wartung und Instandsetzung

**ACHTUNG** Die Pumpe muss von allen Seiten zugänglich sein, um notwendige Sichtkontrollen durchführen zu können.

Für Wartungs- und Instandsetzungsarbeiten ist genügend Raum vorzusehen, besonders für den Ausbau des Antriebsmotors oder des kompletten Pumpenaggregates. Außerdem ist darauf zu achten, dass sämtliche Rohrleitungen ohne Hindernis an- und abgebaut werden können.



**5.6 Laying the pipelines**

**5.6.1 Nominal widths**

The nominal diameters of the pipelines need not necessarily correspond to those of the inlet and outlet branch, however, they must not be smaller. Different nominal diameters of suction branches and suction pipelines are to be compensated by centric transition pieces. Formation of air bags is to be avoided.

Figure DN 1

Recommendation for straight pipeline length before and after the pump

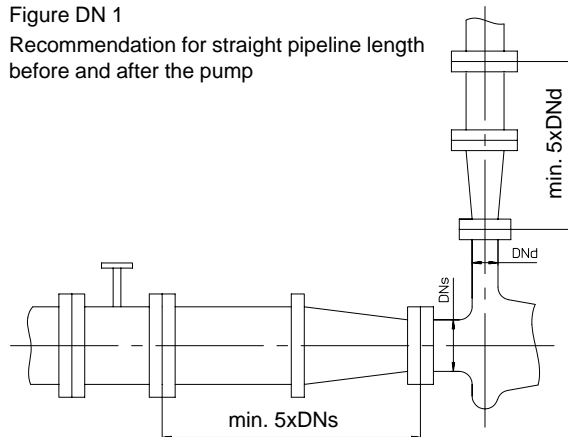

**ATTENTION** Shorter pipelines on the suction side are possible, but may lead to a deterioration of the hydraulic performance data. Shorter pipelines on the discharge side are possible, but may lead to increased noise development.

**ATTENTION** Compensators must not generate any unacceptable additional forces on the pump connection branches. Special care is needed in cases where compensators are used, whose pressurised diameter is greater than the nominal width of the pump connection branches.

**5.6.2 Changes in cross-section and direction**

Sudden changes in cross-section and direction, as well as bends with a bend radius less than 1.5 times the interior pipe width, must be avoided.

**5.6.3 Supports and flange connections**

**ATTENTION** The permissible pipeline forces according to the installation drawing must not be exceeded in any operating status.

We therefore recommend on principle that a calculation of the pipeline forces is performed, which takes into consideration all operating status (e.g. cold/warm, empty/full, depressurised/pressurised, etc.). Changes in position of the pump flange must be observed.

Pipeline supports must always be free sliding and must not rust in (check regularly).

**How to assess a pipeline connection**



To conduct an assessment, the pipeline must be depressurised, completely drained and cooled. The pumping liquid must be disposed of with respect for the environment.

- Disconnect the pipeline from the pump at the connecting flanges.

- After disconnecting the connecting flanges, the pipeline must be freely movable in all directions in the area of expected expansion.

**Note:** up to Ø 150 mm by hand  
from Ø 150 mm with small lever

- The flanges must lie plane-parallel.

**5.6.4 Cleaning pipelines prior to attachment**

Prior to assembly, all pipeline parts and valves must be thoroughly cleaned.

**ATTENTION** No impurities must reach the pump from the pipeline system (e.g. welding beads, residues from preservatives, etc.).

Flange gaskets must not protrude inwards. Blanking flanges, plugs, protective film and/or protective paint on flanges and seals must be removed completely.

**ATTENTION** Filters on suction side must be cleaned regularly. We recommend monitoring with differential manometer and/or contact manometer.

**5.6.5 NPSH observation**

The NPSH conditions of the system must be adapted to the respective pump requirement (NPSH<sub>req.</sub>).

An essential condition is fulfilled if the system NPSH value (NPSH<sub>avail.</sub>) is at least 0,5 m **above** the pump NPSH value (NPSH<sub>req.</sub>). The NPSH<sub>req.</sub> can be taken from the characteristic curves of the relevant pumps.

**ATTENTION** The applicable NPSH values in the characteristic curves are for water with 20°C. For other media and/or temperatures, the NPSH value may deviate from the characteristic curves.

**ATTENTION** Uncertainties in the determination of NPSH conditions, particularly for media other than water and/or other temperatures, must be compensated for by increased safety factors (please consult the manufacturer).

**5.6.6 Suction and inlet pipeline**

In order to avoid the formation of air bags, the suction and inlet pipeline must be laid rising to the pump.

**5.6.6.1 Foot valve and suction basket (suction mode)**

For suction operation, the suction pipeline must be equipped with a foot valve preventing the pump and suction pipeline from running empty while at rest.

The suction basket must be attached so that neither dirt from the sump nor air from the fluid level can enter.

**5.6.6.2 Stop valve (inlet mode)**

A stop valve is to be installed in the inlet pipeline. It must be fully open during operation (see figure DN 1).

**5.6.7 Pressure pipeline**

**5.6.7.1 Stop valve in the pressure pipeline**

A stop valve should be installed in the pressure pipeline.

**5.6.7.2 Non-return valve in the pressure pipeline**



The pump must not run backwards. It is recommended that a non-return valve is fitted between the pressure branch and the stop valve.

**5.6.7.3 Bleeding**

In the pressure pipeline, bleeding facilities should be provided at the highest point and in front of the non-return valve.

### 5.6.8 Auxiliary connections

The positions of the auxiliary connections on the pump are shown in the installation drawing. All auxiliary pipelines must be connected in accordance with the installation drawing, stress-free and sealed.

## 5.7 Safety and control devices

### 5.7.1 Manometers

We recommend to provide suitable pressure gauges in the inlet and pressure pipelines, and in the pressurized auxiliary pipelines.

### 5.7.2 Safety devices in the inlet, delivery and auxiliary pipelines

Safety devices in the form of stop valves must be installed in the pipelines, if not already provided, to allow the pipelines to be shut off and disconnected during maintenance and repair work.

## 5.8 Electrical connections



The power supply cables of the drive motor must be connected by a trained electrician, according to the motor manufacturer's circuit diagram. The valid VDE regulations, the regulations of the local electricity board and the operating manual for the motor must be complied with.

Danger due to electrical power must be excluded and an EMERGENCY STOP switch in accordance with EN 809 must be provided.



**The pump must not run dry, not even for checking the sense of rotation.**

Refer 6.1... **Control of drive motor sense of rotation**

## 5.9 Checking the pressure of the system with built-in pump



If the whole system with built-in pump is to be subjected to a final pressure test, the test pressure must not be more than the maximum permissible internal pressure of the pump (see data sheet).

## 6 Start-up/Shutdown

### 6.1 Preparations for (initial) start-up

#### 6.1.1 Filling and bleeding the pump

Prior to starting up, the pump and the suction and inlet pipeline must be filled with delivery fluid.

During bleeding, the stop valves in the inlet and delivery pipelines must be open to allow air pockets to escape into the piping system, and out from there via the bleeder pipeline.

If the pump fails to build up pressure when started up (see manometer), bleeding must be repeated.



During bleeding of the pump and the plant, hazardous or environmentally harmful fluid and gas emerging must be safely collected and discharged.

#### 6.1.2 Control of drive motor sense of rotation

The sense of rotation of the motor must match the sense of rotation arrow on the pump. To check the sense of rotation, the motor can be switched on briefly when the pump is full.

**ATTENTION** The pump must not run dry, not even for checking the sense of rotation.

In the case of pumps with a mechanical seal that is dependent on the sense of rotation, the motor must always be disconnected in order to check the sense of rotation.

If the sense of rotation is incorrect, the sense of rotation of the three phase motor can be reversed by switching any two phases.

### 6.2 Start-up

#### 6.2.1 General



Before starting, all filling and venting openings must be completely closed.

##### 6.2.1.1 Starting without air ejector

To avoid overloading the drive motor, the pump should be run up only against a closed pressure stop valve during starting.

The stop valve in the inlet pipeline must be fully open.

##### 6.2.1.2 Starting with air ejector A25A

Fully open the stop valve in the inlet pipeline and close the delivery-side valve.

Initiate suction. (For description of function of air ejector see separate Operating Instructions VM 490.0011/...). After conclusion of the suction procedure, switch on the drive and open the pressure-side gate valve until the minimum rate of flow is obtained (see Section 6.2.3).

#### 6.2.2 Drive

Switch on the motor.

Refer to the operating instructions of the drive motor manufacturer.

#### 6.2.3 Minimum rate of flow

Immediately after reaching the operating speed, the pressure-side stop valve must be opened and the pump operated up to at least the minimum rate of flow (see data sheet).

#### 6.2.4 Setting the pump power output values

The pressure-side stop valve must be opened until the required pump power output values are obtained (see data sheet).

#### 6.2.5 Temperature

In order to prevent injuries due to burns, at pumping liquid temperatures higher than 60°C protective devices in accordance with EN 809 must be provided on site.

**ATTENTION**

It must be ensured that the pump housing is evenly heated. Differences in temperature between the top and bottom of the pump, as well as sudden temperature changes, should be avoided.

**Temperature changes in the material of more than 50°C per minute are not permissible.**

### 6.3 Shutdown

- **Pressure pipeline**

If a non-return valve is installed in the pressure pipeline, the stop valve can remain open. Without non-return valve, the stop valve must be closed.

- **Drive**

Switch off the motor. Make sure the pump runs down smoothly and evenly.

- **Inlet line**

Close stop valve in inlet line.



It must be ensured that the pump does not run backwards after switching off. Otherwise, the pump may reach unacceptably high speeds, and shaft seals dependent on the direction of rotation will be severely damaged.

### 6.4 Measures in the event of standstills

Pumped liquid ...	Measures in the event of brief standstill	Measures in the event of prolonged standstill
May solidify + has a preservative effect ①	Hear or drain pump	Drain pump
May solidify + does not have a preservative effect	Hear or drain pump	Drain and preserve pump ①
Does not solidify + has a preservative effect ①	–	–
Does not solidify + does not have a preservative effect	–	Drain and preserve pump ①

① See section 3.3

## 7 Maintenance/Repair

### 7.1 Maintenance

- The instructions in Section 2, *Safety*, must be observed in maintenance and repair work.
- Regular monitoring and maintenance of the pump and the drive motor are essential for optimum service life and safety.

#### 7.1.1 General monitoring

1. The pump must not run dry.
2. The pump must not run in cavitation.
3. The minimum delivery rate must always be maintained (see Section 6.2.).
4. The drive motor must not be overloaded.
5. The bearing temperature of rolling bearings must not exceed 120°C.
6. The shaft seal must have no inadmissible leakage.
7. Changes to the normal operating data may indicate faults. The causes must be established.
8. Installed standby pumps must be started up once a week.

#### 7.1.2 Maintenance of components

##### 7.1.2.1 Bearing

The built-in groove ball bearing is maintenance-free. The nominal service life of the groove ball bearing is designed for a minimum of 2 years continuous operation, in accordance with DIN ISO 281. The actual usable life may be lower, due to intermittent operation, high temperature, low viscosity or the like.

The running noises and the temperature in the bearing area must be checked at regular intervals. We recommend monitoring bearings by means of shock pulse measurements. If damage to a bearing is detected, the groove ball bearing must be replaced.



The bearing area can become very hot.

**Risk of burning if touched!**

**As a precautionary measure, we recommend that the groove ball bearing is replaced every 2 years.**

##### 7.1.2.2 Shaft seal

The built-in mechanical seal is maintenance-free. A maximum dripping rate of 10 g/h may occur during operation and is normal. If the dripping is heavier, the shaft seal must be replaced.



A defective shaft seal can cause uncontrolled discharge of pumping liquid.

**This constitutes a hazard to people (possibility of spraying liquid) and to the environment!**

##### 7.1.2.3 Drive

Refer to the operating instructions of the motor manufacturer.

### 7.2 Repair

#### General



The system operator is responsible for ensuring that instruction in safety is provided. The personnel must be made aware of all hazards that can arise in connection with the pumped liquid or the plant.

#### Mounting and repair work

Trained Service fitters are available on request to carry out mounting and repair work.



For all repairs, it must be ensured that the pump is depressurised, completely drained and cool. The motor must be protected against unintended switching on.

We must refuse acceptance of repair work on pumps filled with fluid, for the protection of our staff and for environmental reasons. The expenditures for disposal with respect to the environment are to be carry by the customer/operating company.

#### Hazardous substances



Where repairs are to be carried out on pumps which have been operated with hazardous substances ① and/or environmentally harmful media, the customer/operator must inform its own personnel on site, or our personnel where repairs are returned to our factory or a service workshop, without being specifically requested to do so.

Together with the request for a Service fitter a verification of delivery material, for example in the form of a DIN safety data sheet, must be submitted to us. Alternatively, you can request a certificate of safety (form no. 448/191) from our Service department, filling it out truthfully, correctly and in full. Send the completed form to the center commissioned with carrying out the repair, or hand it to our Service fitter.

#### ① Hazardous substances are:

- Toxic substances
- Health-endangering substances
- Corrosive substances
- Irritants
- Explosive substances
- Fire-inducing substances
- Highly flammable, easily flammable and normally flammable substances
- Carcinogenic substances
- Substances impairing fertility
- Genetically distorting substances
- Substances in other ways hazardous to humans



Pumps or units which pump hazardous substances or substances that are dangerous to the environment must be completely decontaminated.

**7.2.1 Dismounting the centrifugal pump**

Before dismounting, the following work must be carried out:



- Electrical danger must be eliminated! The motor must be secured against being switched on. If necessary, the power supply cable must be disconnected from the motor by an authorized electrician.
- Close all stop devices in the inlet and delivery pipeline, and in the auxiliary pipelines.
- Allow the pump housing to cool to ambient temperature.
- Drain the fluid in flowable condition from the pump.  
**Note:** Use a collecting tank.
- The pump must be depressurized and drained.



- Hazardous substances and/or environmentally harmful media must be drained off and collected such that no danger to life and limb is created. Environmentally compatible disposal must be ensured.
- Remove auxiliary pipelines, if fitted.
- Dismount manometer lines, manometers and holding devices.
- Dismount protection against accidental contact.



**The pump must be dismantled by a qualified technician using the pertaining drawings.**

To prevent damage, it is especially important to ensure that the components are dismantled concentrically and that they are not tilted.

**Dismounting instructions:**

- The pumps are designed, as standard, with an intermediate shaft. This means that the insert unit can be dismantled without the volute casing, the foot mounted lantern bracket, the pipelines or the motor having to be removed.
- After removal of the intermediate shaft (212.01) it must be ensured that the insert unit is removed concentrically and not tilted, in order to prevent damage.
- After relieving the load, lifting eyes can be screwed into the tapped holes of the jack screws (908.1), in order to remove the insert unit.

**7.2.2 Mounting the centrifugal pump**



Before remounting check all parts for wear and aging and, as necessary, replace with **original replacement parts**.

Clean all parts before mounting. Always fit new gaskets.



**The pump must be mounted by a qualified technician using the pertaining drawings. The prescribed tightening torque must be observed.**

To prevent damage, it is especially important to ensure that the components are mounted concentrically and that they are not tilted.

**Mounting instructions:**

- Lifting eyes and/or jack screws (908.01) in the housing cover must be unscrewed far enough.
- After fitting the insert unit, the pump shaft must lie exactly flush with the motor shaft.  
It must be possible to mount the intermediate shaft (212.01) and coupling part (860.01) without using excessive force.
- After tightening the screws, it must be possible to turn the pump and drive manually without straining points.

**7.2.3 Tightening torque**

**Note:** With poor and lightly greased surfaces, the values must be increased by 10–15%, in order to reach the required performance.

Part no.	Thread	Quality	Tightening torque [Nm]
901.01	M 10	A4	11,3
	M 12		19,5
	M 16		47,0
901.03	M 10	A4	13,5
	M 12		23,0
	M 16		55,0
901.05	M 6	8.8	2,8
	M 8		6,5
901.06	M 10	8.8	13,5
	M 12		23,0
901.07	M 10	8.8	13,5
	M 12		23,0
901.08	M 6	ST	2,5
901.09	M 6	ST	2,5
901.10	M 12	5.6	20,0
	M 16		55,0
	M 20		110,0
901.15	M 12	8.8	20,0
	M 16		55,0
	M 20		110,0
920.06	M 12	8.8	19,5
922.01	M 20 x 1,5	A4	100,0
	M 24 x 1,5		175,0
	M 30 x 1,5		365,0
	M 36 x 1,5		615,0
Fixing to foundation	M 20	8.8	110,0
	M 24		190,0
	M 30		380,0

**Following the mounting the centrifugal pump, the following operations are to be performed.**

- Attach protection against accidental contact.
- For pumps with air ejector: attach pipe connection.
- Attach manometer pipelines, manometer and holding devices to the pump.



- Electrical danger must be eliminated! Power supply cables must only be connected by qualified electricians. Pay attention to sense of rotation.

**Start up pump as per instructions in Section 6.**

### 7.3 Replacement parts

The application guidelines in accordance with DIN 24 296 can be taken as a basis for spare parts stock holding (see Section 7.3.2).

However, for reasons of operational safety, we recommend the stocking of complete insert units or spare pumps.

**Advantage:** In the event of damage, a defective unit can be replaced by a spare unit without great expenditure and in a very short space of time.

#### 7.3.1 Ordering spare/replacement parts

The following details are required for handling orders for replacement and spare parts:

- Pump abbreviation ①
- Pump number ①
- Year of construction ①
- Part number
- Denomination
- Quantity

① refer to name plate

#### 7.3.2 Replacement parts for two-year continuous operation as per DIN 24 296

Part No.	Part denomination	Number of identical pumps (including standby pumps)							
		2	3	4	5	6 und 7	8 und 9	10 und mehr	
		Set/Replacement parts quantity							
230.01	Impeller	1	1	1	2	2	3	30%	
210.01 ①	Shaft with impeller nut spring ring key	922.01 936.01 940.01	1	1	2	2	2	3	30%
321.01	Groove ball bearing		1	1	2	2	3	4	50%
433.01	Mechanical seal		2	3	4	5	6	7	90%
div.	Set of Joints and Gaskets		4	6	8	8	9	12	150%

① Can be purchased as assembly group/sale group.

## 8 Operating Faults, Causes and Remedial Action

### 8.1 Faults with reference number for cause and remedial action

The table below is intended as a guide to identifying faults and their possible causes.

If faults occur which are not listed here, or which cannot be traced back to the listed causes, we recommend consulting the factory, or one of our branch offices or sales offices.



The pump must be depressurized and drained when faults are being rectified.

Centrifugal pump faults	Reference numbers for cause and remedial action
Delivery rate too low	1, 2, 3, 4, 5, 6, 7, 8, 9, 21, 22
Delivery head too low	2, 3, 4, 5, 6, 7, 8, 9, 21, 22
Power consumption of pump too high	9, 11, 12, 17, 21, 22
Delivery pressure too high	9, 12
Bearing temperature increased	17, 18, 25
Pump housing leaky	23
Heavy leakage of shaft seal	10, 13, 17, 27
Pump not operating smoothly	1, 2, 3, 4, 5, 6, 8, 11, 17, 24, 26
Pump gets hot	2, 5, 26

### 8.2 Causes and remedial action

Ref. no.:	Cause	Remedial action
1	Delivery head higher than nominal delivery head of pump.	1. Open stop valve in pressure pipeline until operating point is reached. 2. Install impeller with larger diameter. 3. Increase rotation speed (turbine, frequency control, ...) ①
2	Pump or pipelines not properly bled or filled.	Bleed and top up pump or pipelines.
3	Inlet pipeline or impeller blocked.	Clean pipelines and impeller.
4	Air pockets forming in pipeline.	Perhaps install a vent valve, or lay pipeline differently.
5	NPSH <sub>available</sub> (inlet) too low.	1. Check fluid level in inlet tank. 2. Open stop valve in inlet pipeline fully. 3. Lay inlet pipeline differently if friction losses are too high. 4. Check filter in inlet pipeline, if fitted. 5. Check inlet flow conditions of pump.
6	Wrong direction of rotation of pump.	Reverse polarity of any two phases on motor.
7	Rotation speed too low.	Increase rotation speed (turbine, frequency control, ...). ①
8	Excessive wear on inner pump parts.	Replace worn parts.
9	Density or viscosity of delivery medium does not comply with pump design data.	Consult the factory in the event of faults due to non-compliance with design data. ①
10	Shaft sleeve damaged.	Mount new shaft sleeve.
11	Delivery head lower than nominal delivery head of pump.	1. Regulate operating point with stop valve in pressure pipeline. 2. Turn off impeller in event of continuous overload.
12	Rotation speed too high.	Reduce rotation speed (turbine, frequency control, ...). ①
13	Shaft seal damaged.	Check shaft seal parts for wear and replace if necessary.
14	–	–
15	–	–
16	–	–
17	Pump twisted.	Check pipelines for twists in connections.

18	Excessive axial thrust.	Clean relief bore holes in impeller.
19	–	–
20	–	–
21	Motor voltage incorrect.	Use motor with correct voltage.
22	Motor runs only to two phases.	1. Check cable connection. 2. Replace fuses.
23	Screws not tight.	1. Tighten screws. 2. Replace gaskets.
24	Impeller out-of-true.	1. Clean impeller. 2. Re-balance impeller.
25	Groove ball bearing defective.	Replace groove ball bearing.
26	Delivery rate below minimum.	Increase delivery rate to minimum.
27	Pumped liquid corroding mechanical seal material.	Check pumped liquid (e.g.: incorrect temperature, concentration, dosing of additives, etc.)

① Consult factory



## 9 Associated Documentation

### 9.1 Sectional drawing with part list, Series MI

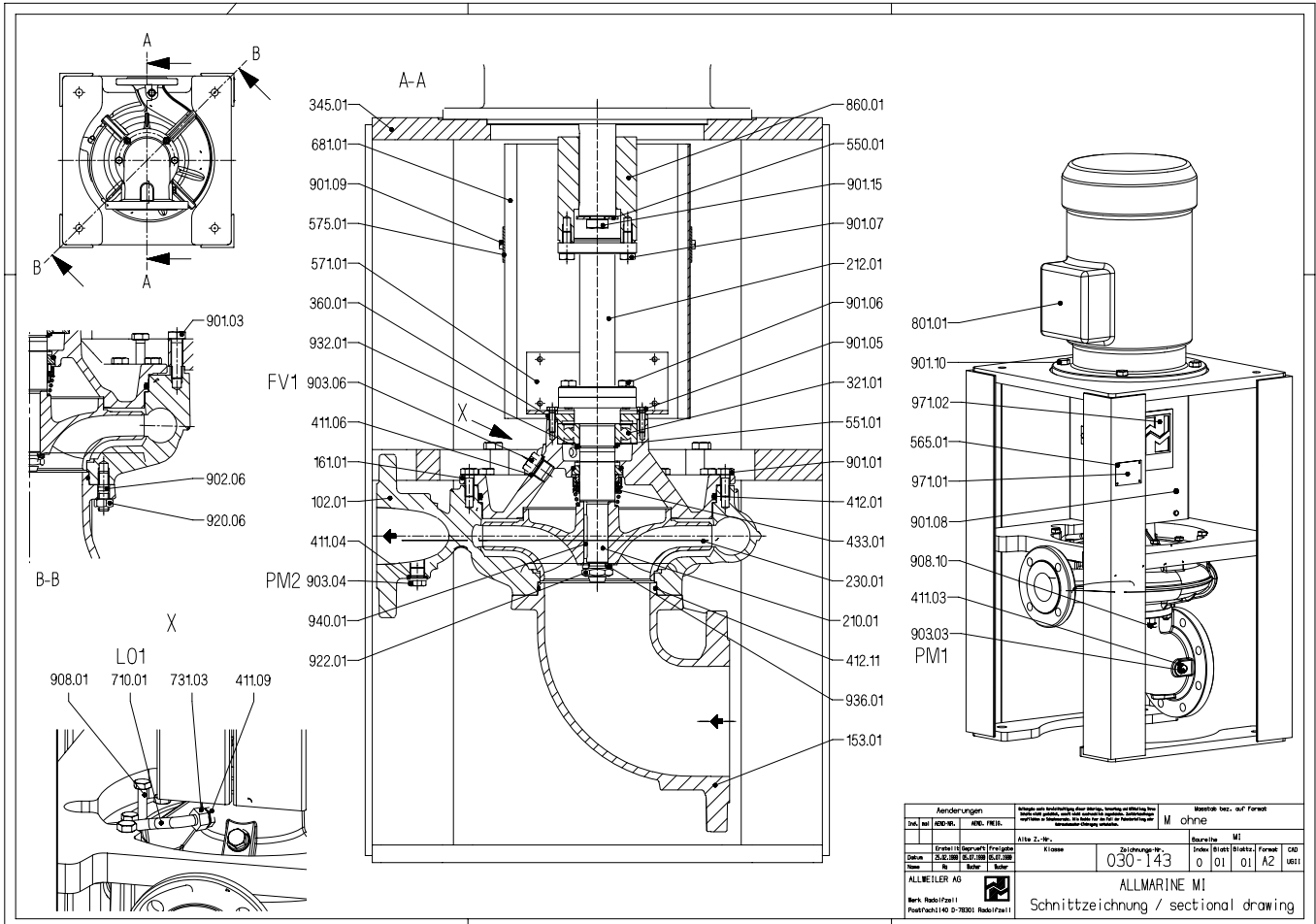

Denomination	Part No.	Denomination	Part No.	Denomination	Part No.
Volute casing	102.01	Strap	575.01	Jack screw	908.10
Suction branch	153.01	Coupling guard	681.01	Hexagon nut	920.06
Casing cover	161.01	Nipple joint	710.01	Impeller nut	922.01
Shaft	210.01	Screwed connection	731.03	Circlip	932.01
Intermediate shaft	212.01	Flange motor	801.01	Spring ring	936.01
Impeller	230.01	Coupling part	860.01	Key	940.01
Radial ball bearing	321.01	Hexagon screw	901.01	Name plate	971.01
Foot mounted lantern bracket	345.01	Hexagon screw	901.03	Name plate	971.02
Bearing cover	360.01	Hexagon screw	901.05		
Joint ring	411.03	Hexagon screw	901.06		
Joint ring	411.04	Hexagon screw	901.07		
Joint ring	411.06	Hexagon screw	901.08		
Joint ring	411.09	Hexagon screw	901.09		
O-ring	412.01	Hexagon screw	901.10		
O-ring	412.11	Hexagon screw	901.15		
Mechanical seal	433.01	Hexagon screw	901.15		
Disc	550.01	Stud bolt	902.06		
Supporting disc	551.01	Screw plug	903.03		
Rivet	565.01	Screw plug	903.04		
Clamp	571.01	Screw plug	903.06		
		Jack screw	908.01		

Connections	
LO1	Leakage outlet
FV1	Filling/Bleeding
PM1	Pressure measurement
PM2	Pressure measurement

## 9.2 Sectional drawing with part list, Series MA

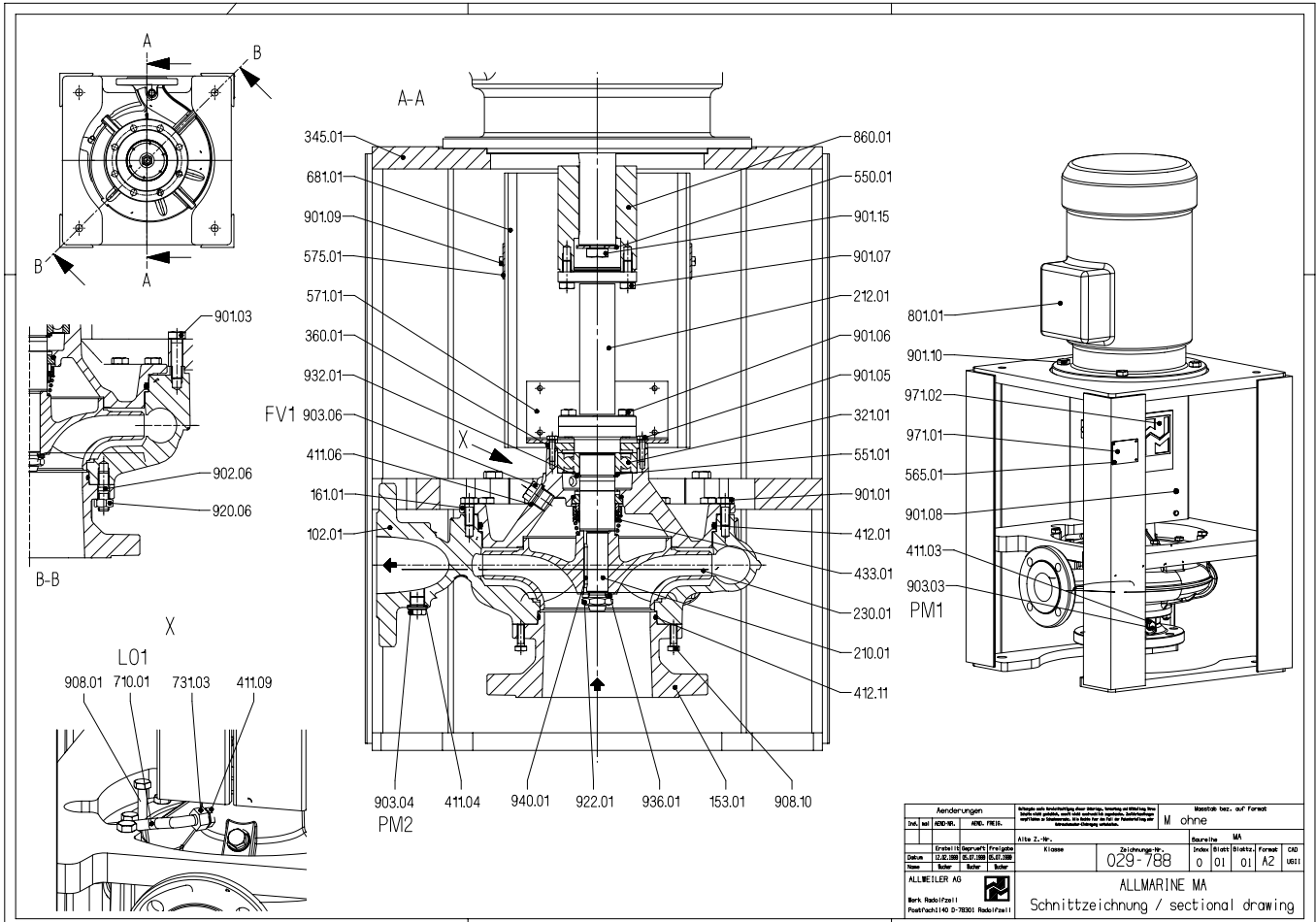

Denomination	Part No.	Denomination	Part No.	Denomination	Part No.
Volute casing	102.01	Strap	575.01	Jack screw	908.10
Suction branch	153.01	Coupling guard	681.01	Hexagon nut	920.06
Casing cover	161.01	Nipple joint	710.01	Impeller nut	922.01
Shaft	210.01	Screwed connection	731.03	Circlip	932.01
Intermediate shaft	212.01	Flange motor	801.01	Spring ring	936.01
Impeller	230.01	Coupling part	860.01	Key	940.01
Radial ball bearing	321.01	Hexagon screw	901.01	Name plate	971.01
Foot mounted lantern bracket	345.01	Hexagon screw	901.03	Name plate	971.02
Bearing cover	360.01	Hexagon screw	901.05		
Joint ring	411.03	Hexagon screw	901.06		
Joint ring	411.04	Hexagon screw	901.07		
Joint ring	411.06	Hexagon screw	901.08		
Joint ring	411.09	Hexagon screw	901.09		
O-ring	412.01	Hexagon screw	901.10		
O-ring	412.11	Hexagon screw	901.15		
Mechanical seal	433.01	Stud bolt	902.06		
Disc	550.01	Screw plug	903.03		
Supporting disc	551.01	Screw plug	903.04		
Rivet	565.01	Screw plug	903.06		
Clamp	571.01	Jack screw	908.01		
				Connections	
				LO1	Leakage outlet
				FV1	Filling/Bleeding
				PM1	Pressure measurement
				PM2	Pressure measurement

9.3 Explosion drawing

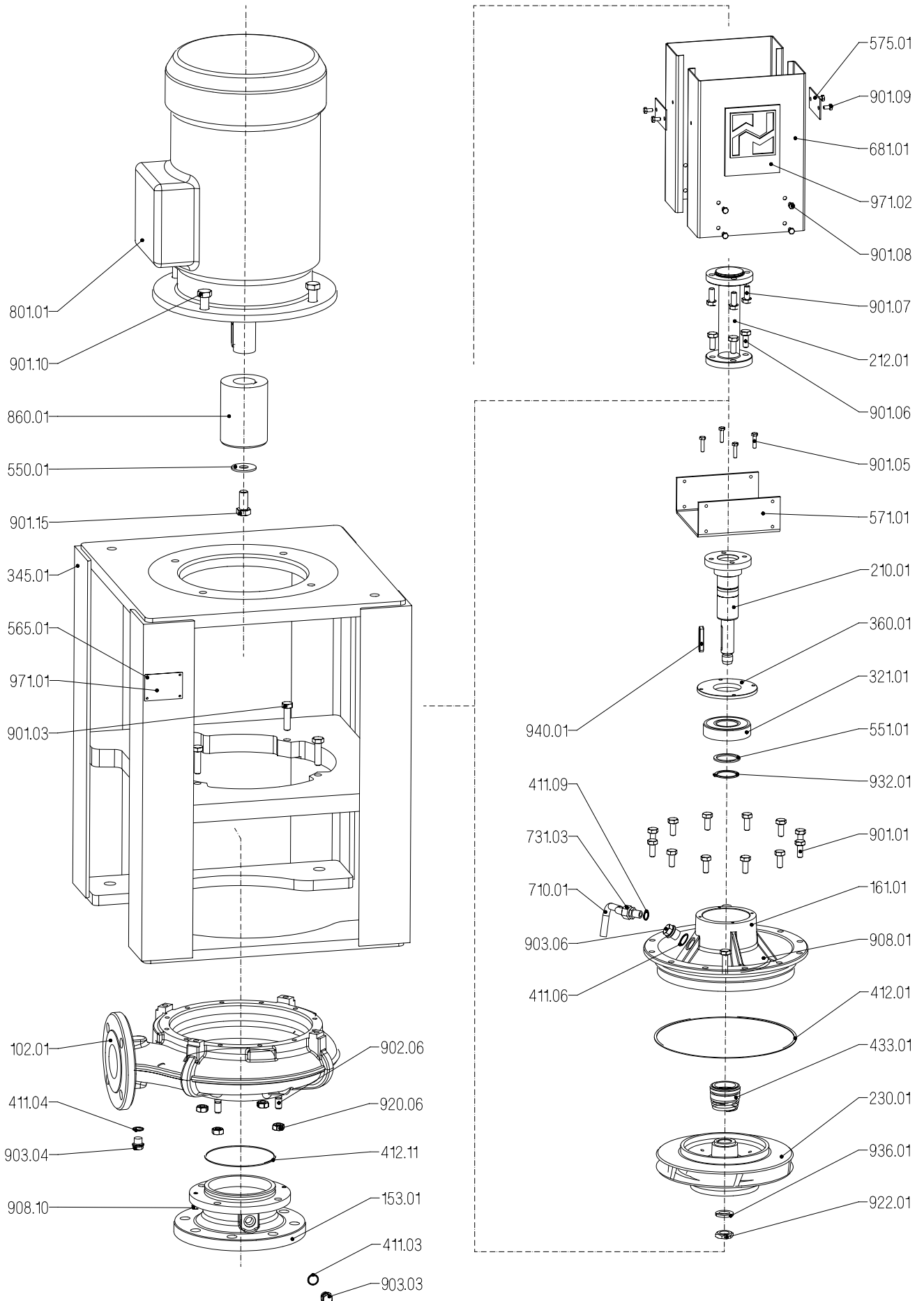

Subject to technical alterations.

---



A Member of the  
COLFAX PUMP GROUP

**ALLWEILER AG • Werk Radolfzell**  
**Postfach 1140 • 78301 Radolfzell**  
**Allweilerstraße 1 • 78315 Radolfzell**  
Germany  
Tel. +49 (0)7732 86-0  
Fax +49 (0)7732 86-436  
E-mail: [service@allweiler.de](mailto:service@allweiler.de)  
Internet: <http://www.allweiler.com>