

# E2 2" Clamped Metallic Pumps Specifications and Performance

## SPECIFICATIONS

E2

**FLOW RATE** (Adjustable) .... 0-155 gpm (586 lpm)

**PORT SIZE**

Inlet and Outlet..... 2.0" NPT (BSP)

**AIR INLET**..... 0.50" NPT

**AIR EXHAUST**..... 0.75" NPT

**SUCTION LIFT** .... 20' Dry/25' Wet (6.10m/7.62m)

Teflon®..... 10' Dry/20' Wet (3.05m/6.10m)

**MAX. PARTICLE SIZE** (Dia.) ..... 0.25"(6.35mm)

**SHIPPING WEIGHTS**

Aluminum ..... 70 lbs (31.75 kg)

Cast Iron, Stainless..... 115 lbs (52.16 kg)

Hastelloy C..... 125 lbs (56.70 kg)



## PERFORMANCE

Determined by actual flow meter tests.

E2

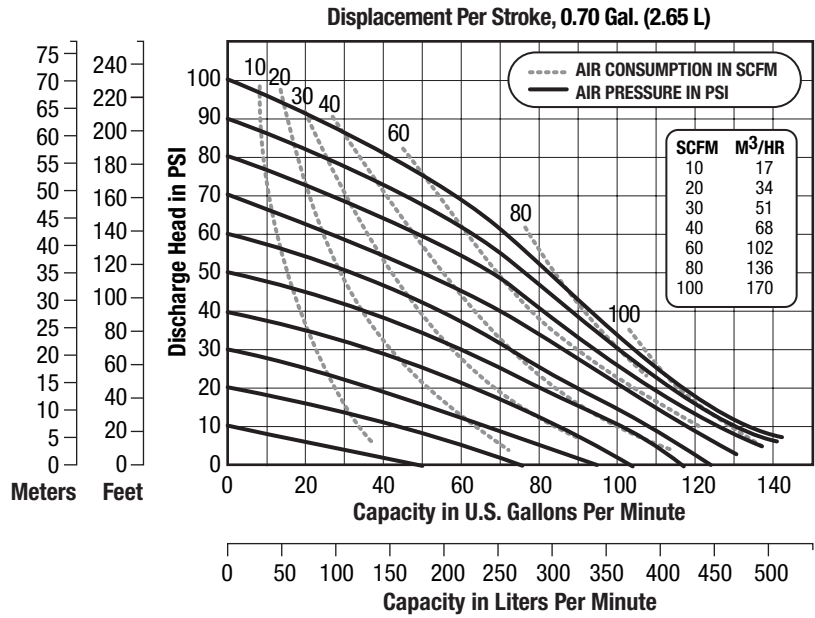

**NOTE:** For E2 pumps fitted with Teflon® diaphragms, reduce water discharge figures by 20%. Suction lift is reduced to 10' (3.05m) dry and 20' (6.10m) wet.

**CAUTION:** Do not exceed 125 psig (8.5 bars) air supply or liquid pressure.

## DIMENSIONS

Consult factory for certified drawings.

E2

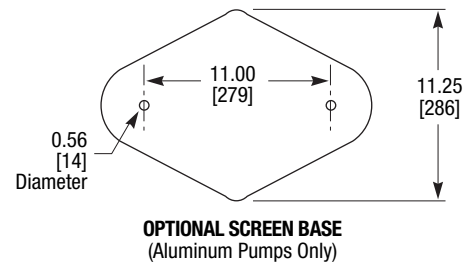
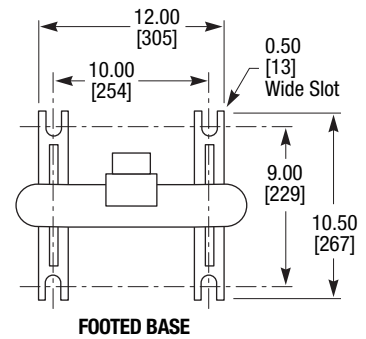
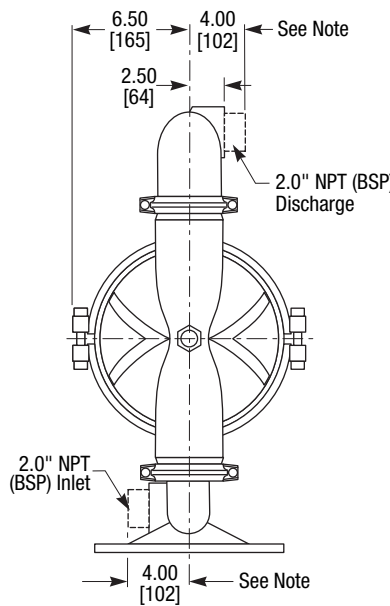
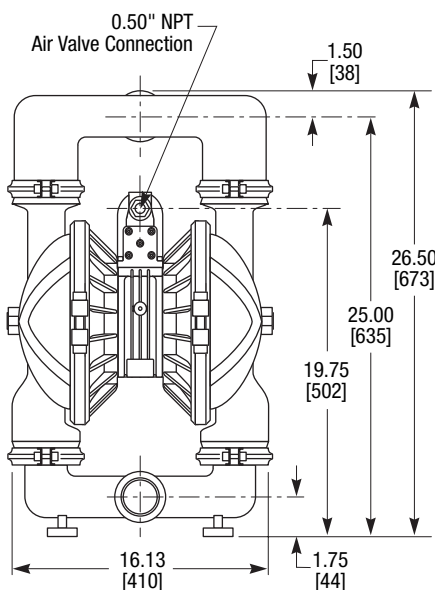

**NOTE:** Cast-In-Place Nipple, Aluminum Pump Only. Female threaded on others.

inches [mm]

# E2 2" Bolted Metallic Pumps Specifications and Performance

## SPECIFICATIONS

E2

- FLOW RATE** (Adjustable) .... 0-155 gpm (586 lpm)  
**PORT SIZE**  
 Inlet and Outlet ... 2.0" ANSI, 150 lb class (DIN 50)  
**AIR INLET** ..... 0.50" NPT  
**AIR EXHAUST** ..... 0.75" NPT  
**SUCTION LIFT** .... 20' Dry/25' Wet (6.09m/7.62m)  
 Teflon® ..... 10' Dry/20' Wet (3.04m/6.09m)  
**MAX. PARTICLE SIZE** (Dia.) ..... 0.25"(6.35mm)  
**SHIPPING WEIGHTS**  
 Stainless Steel ..... 120 lbs (54 kg)  
 Hastelloy C ..... 120 lbs (54 kg)  
 Cast Iron ..... 120 lbs (54 kg)



## PERFORMANCE Determined by actual flow meter tests.

E2

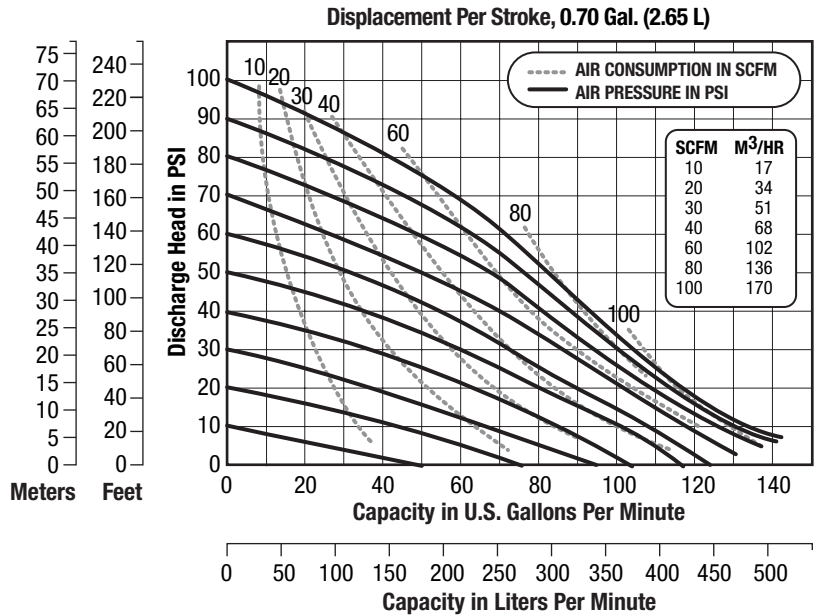

**NOTE:** For E2 pumps fitted with Teflon® diaphragms, reduce water discharge figures by 20%. Suction lift is reduced to 10' (3.05m) dry and 20' (6.10m) wet.

**CAUTION:** Do not exceed 125 psig (8.5 bars) air supply or liquid pressure.  
**Horizontal Discharge Model Available.**

## DIMENSIONS Consult factory for certified drawings.

E2

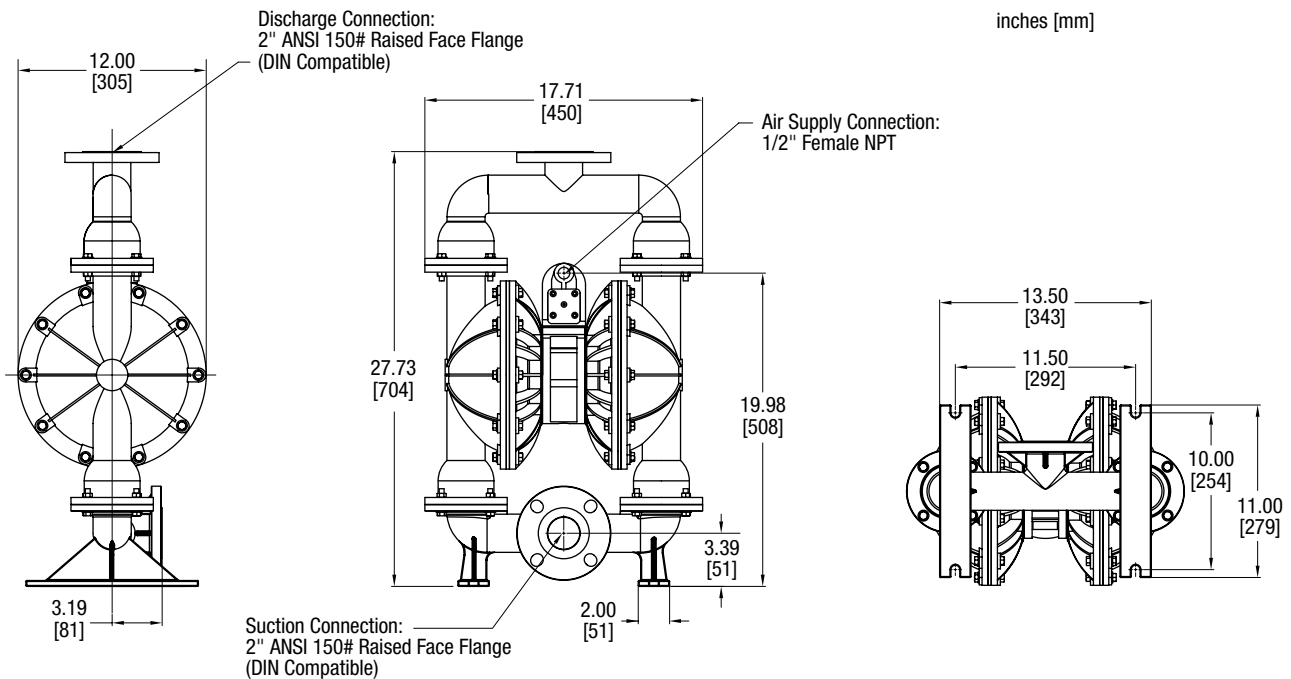

# E2 2" Aluminum Bolted Pumps Specifications and Performance

## SPECIFICATIONS

E2

**FLOW RATE** (Adjustable) .... 0-174 gpm (658 lpm)

**PORT SIZE**

Inlet and Outlet ..... 2.0" NPT (BSP)

**AIR INLET** ..... 0.50" NPT

**AIR EXHAUST** ..... 0.75" NPT

**SUCTION LIFT** ... 20' Dry/25' Wet (6.09m/7.62m)

Teflon®..... 10' Dry/20' Wet (3.04m/6.09m)

**MAX. PARTICLE SIZE** (Dia.) ..... 0.43"(11mm)

**SHIPPING WEIGHT**

Aluminum ..... 73.5 lbs (33 kg)



## PERFORMANCE

Determined by actual flow meter tests.

E2

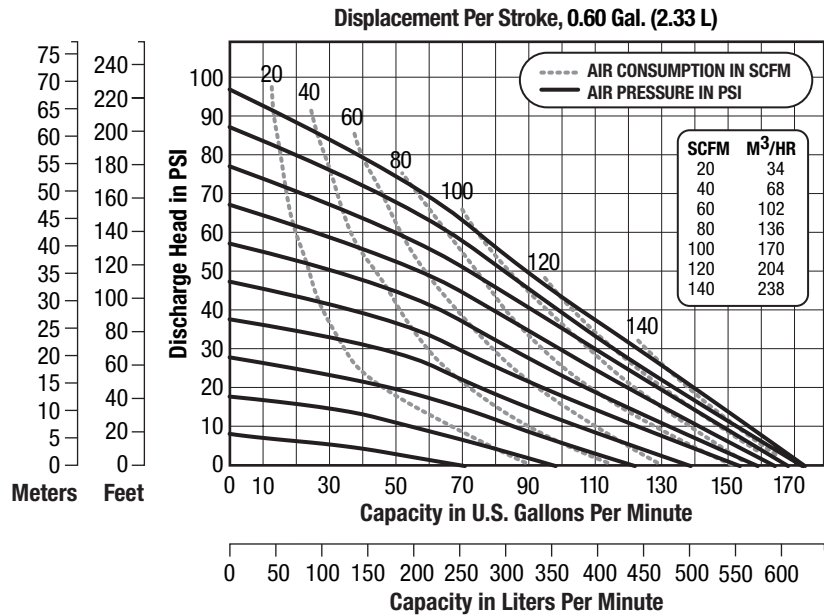

**NOTE:** For E2AL pumps fitted with Teflon® diaphragms, reduce water discharge figures by 20%. Suction lift is reduced to 10' (3.05m) dry and 20' (6.10m) wet.

**CAUTION:** Do not exceed 125 psig (8.5 bars) air supply or liquid pressure.

## DIMENSIONS

Consult factory for certified drawings.

E2

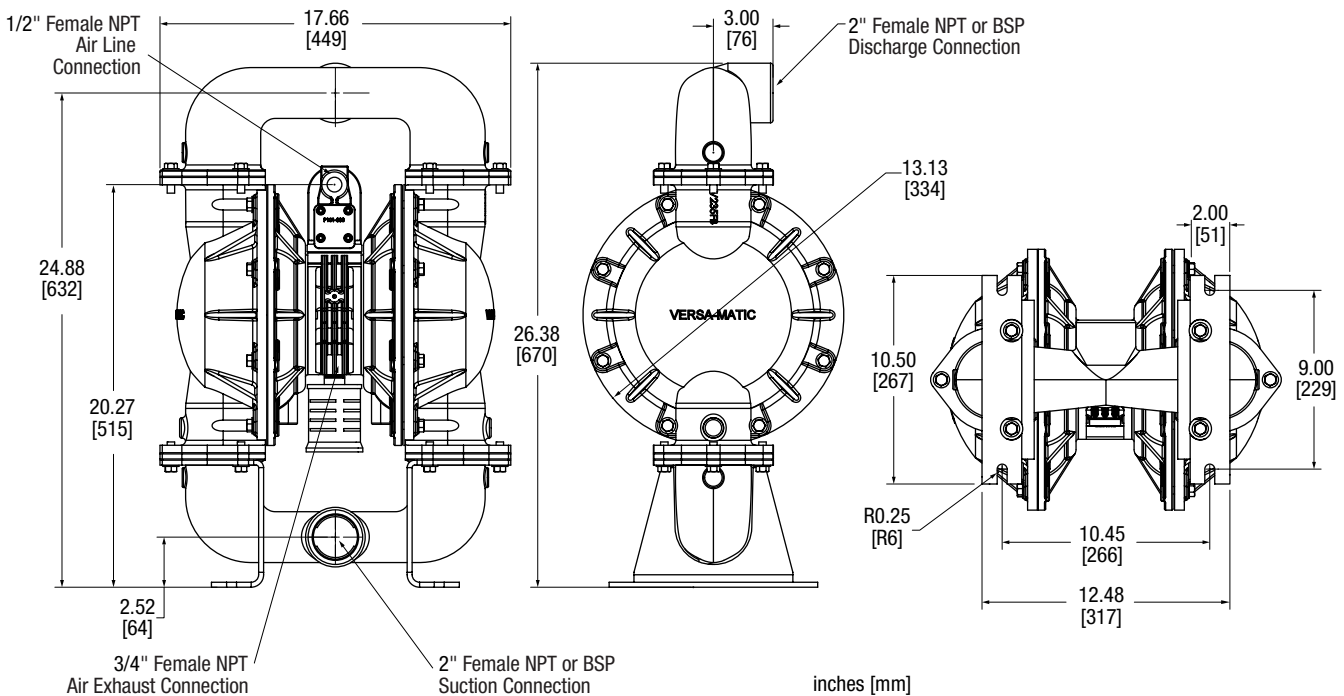

# E2 2" Flap Valve Pumps Specifications and Performance

## SPECIFICATIONS

E2

**FLOW RATE** (Adjustable) .... 0-180 gpm (681 lpm)  
**PORT SIZE**  
 Inlet and Outlet ..... 2.0" Male NPT (BSP)  
**AIR INLET** ..... 0.50" NPT  
**AIR EXHAUST** ..... 0.75" NPT  
**SUCTION LIFT**  
 ..... 10' Dry/10' Wet (3.048m/3.048m)  
**MAX. PARTICLE SIZE** (Dia.) ..... 1.125" (28.57mm)  
**SHIPPING WEIGHT**  
 Aluminum ..... 88 lbs (39.92 kg)



## PERFORMANCE

Determined by actual flow meter tests.

E2

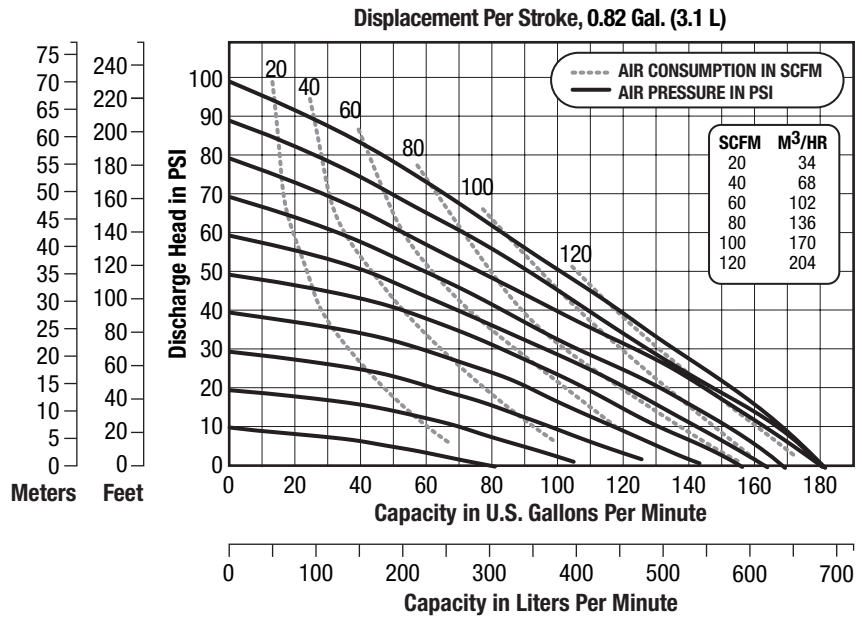

**NOTE:** For E2FV pumps fitted with Teflon® diaphragms, reduce water discharge figures by 20%. Suction lift is reduced to 10' (3.05m) dry and 20' (6.10m) wet.

**CAUTION:** Do not exceed 125 psig (8.5 bars) air supply or liquid pressure.

## DIMENSIONS

Consult factory for certified drawings.

E2

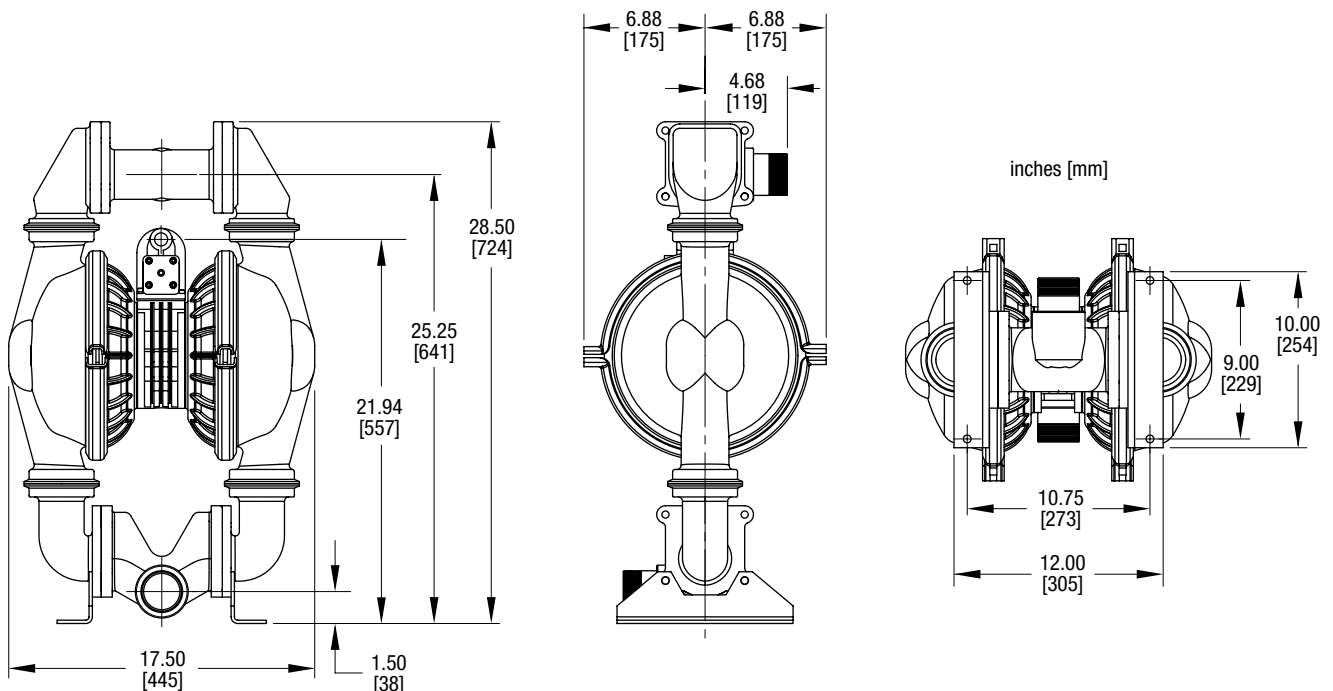

# E2 2" Plastic Bolted Pumps: Standard Porting Specifications and Performance

## SPECIFICATIONS

E2

**FLOW RATE** (Adjustable) .... 0-155 gpm (586 lpm)  
**PORT SIZE**

Inlet and Outlet..... 2.0" ANSI, 150 Class (DIN 50)

**AIR INLET** ..... 0.50" NPT

**AIR EXHAUST** ..... 0.75" NPT

**SUCTION LIFT** .... 20' Dry/25' Wet (6.10m/7.62m)

Teflon®..... 10' Dry/20' Wet (3.05m/6.10m)

**MAX. PARTICLE SIZE** (Dia.) ..... 0.25"(6.35mm)

### SHIPPING WEIGHTS

E2PA ..... 72 lbs (32.68 kg)

E2PS ..... 106 lbs (48.12 kg)

E2KA ..... 98 lbs (44.49 kg)

E2KS ..... 132 lbs (59.92 kg)



## PERFORMANCE Determined by actual flow meter tests.

E2

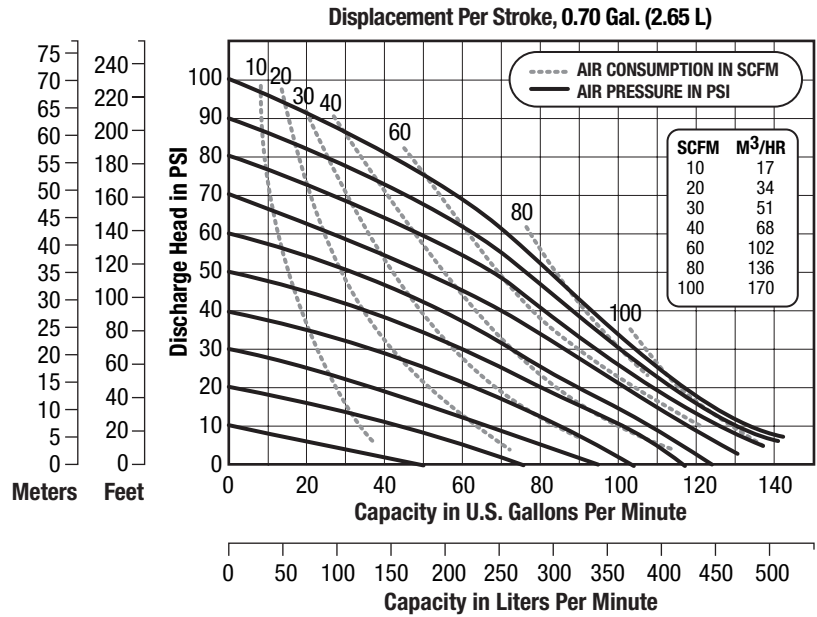

**NOTE:** For E2P pumps fitted with Teflon® diaphragms, reduce water discharge figures by 20%. Suction lift is reduced to 10' (3.05m) dry and 20' (6.10m) wet.

**CAUTION:** Do not exceed 100 psig (6.9 bars) air supply or liquid pressure.

## DIMENSIONS Consult factory for certified drawings.

E2

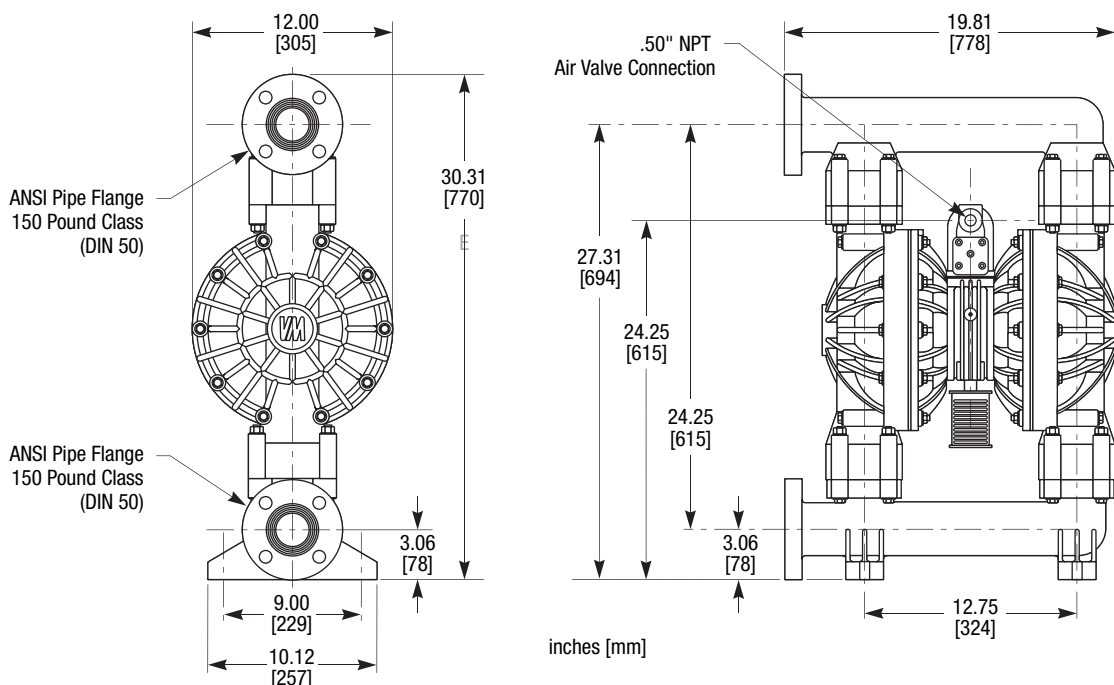

# E2 2" Plastic Bolted Pumps: Optional Porting Specifications and Performance

## SPECIFICATIONS

E2

**FLOW RATE** (Adjustable) .... 0-155 gpm (586 lpm)  
**PORT SIZE**

Inlet and Outlet..... 2.0" ANSI, 150 Class (DIN 50)

**AIR INLET** ..... 0.50" NPT

**AIR EXHAUST** ..... 0.75" NPT

**SUCTION LIFT** .... 20' Dry/25' Wet (6.10m/7.62m)

Teflon®..... 10' Dry/20' Wet (3.05m/6.10m)

**MAX. PARTICLE SIZE** (Dia.) ..... 0.25"(6.35mm)

### SHIPPING WEIGHTS

E2PA ..... 76.2 lbs (34.56 kg)

E2PS ..... 110.2 lbs (49.99 kg)

E2KA ..... 102.2 lbs (46.36 kg)

E2KS ..... 136.2 lbs (61.78 kg)



## PERFORMANCE Determined by actual flow meter tests.

E2

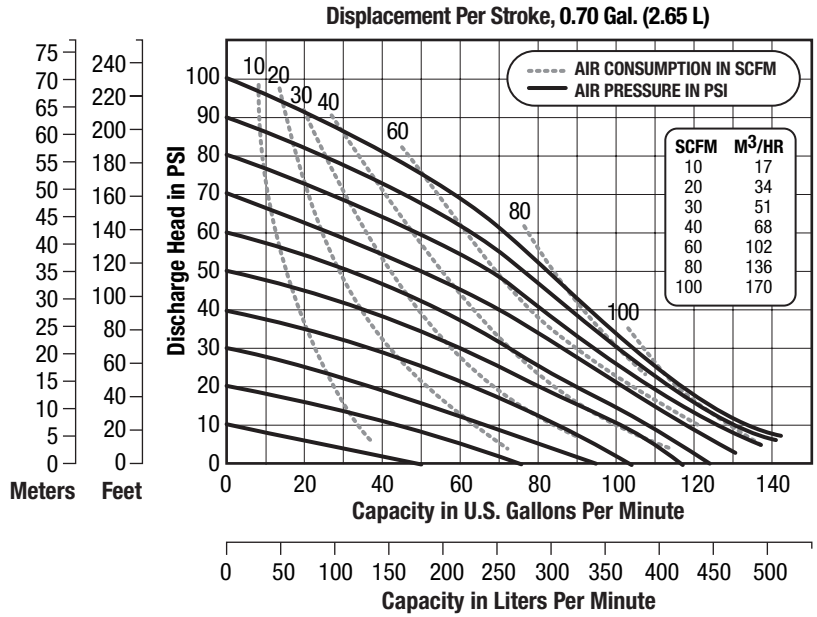

**NOTE:** For E2P pumps fitted with Teflon® diaphragms, reduce water discharge figures by 20%. Suction lift is reduced to 10' (3.05m) dry and 20' (6.10m) wet.

**CAUTION:** Do not exceed 100 psig (6.9 bars) air supply or liquid pressure.  
**Adjustable Inlet/Discharge.**

## DIMENSIONS Consult factory for certified drawings.

E2

