

OPERATING INSTRUCTIONS

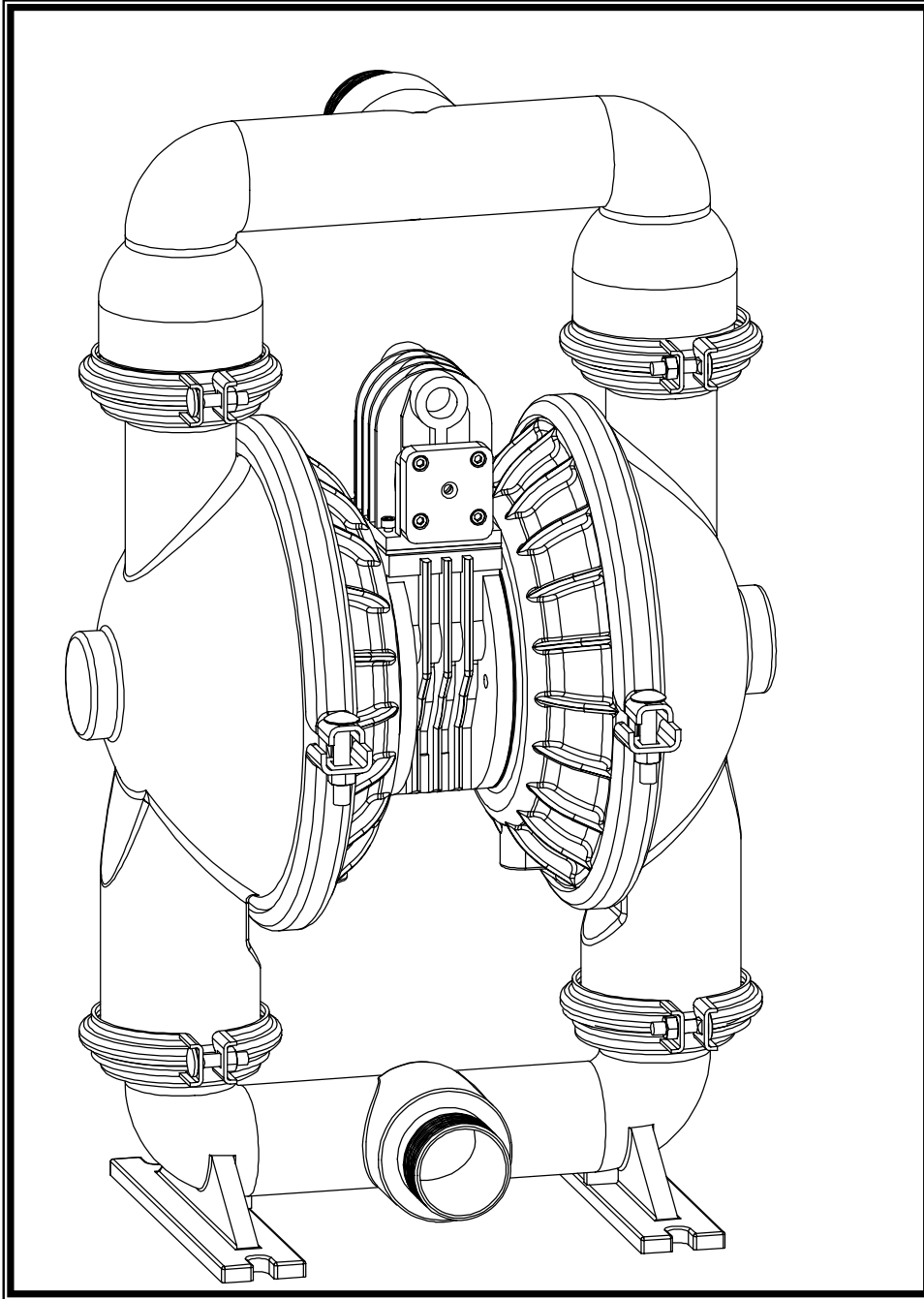

**2" Elima-Matic
Pumps**

Specifications and Performance

Volumes indicated on chart were determined by actual flow meter tests.

Versa-Matic Model E2, 2"

- Flow Rate Adjustable To0-155 gpm (586 lpm)
- Port Size
 - Inlet2.0" NPT (BSP)
 - Discharge2.0" NPT (BSP)
 - Air Inlet0.5" NPT
 - Air Exhaust0.75" NPT
- Suction Lift20' (6.096m) Dry/
25' (7.62m) Wet
- Teflon10' (3.048m) Dry/
20' (6.096m) Wet
- Max. Particle Size (Diameter)0.25" (6.35mm)
- Shipping Weights
 - Aluminum70 lbs (31.78 kg)
 - Cast Iron or Stainless115 lbs (52.21 kg)
 - Hastelloy C125 lbs (56.75 kg)

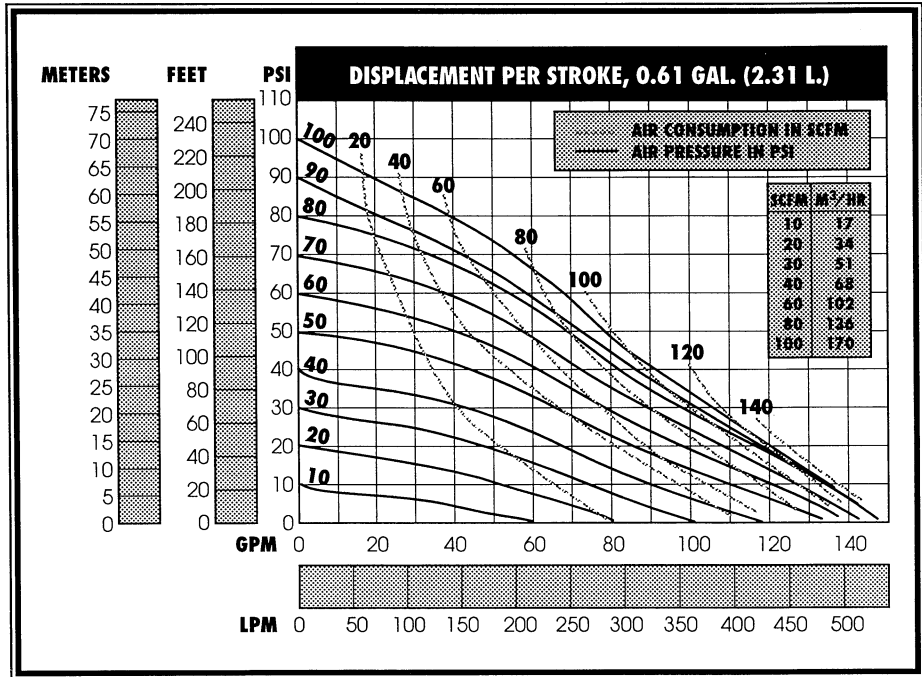

Caution: Do not exceed 125 psig (8.5 bars) air supply pressure.

Note: For E2 pumps fitted with Tef-Matic™ diaphragms, reduce water discharge figures by 20%. Suction lift is reduced to 10' (3.048m) dry and 20' (6.096m) wet.

Teflon® is a registered trademark of E.I. DuPont. Gortex® is a registered trademark of W.L. Gore.

TERM	INCHES	METRIC MM
A	16.125	409.52
B	1.5	38.10
C	1.75	44.25
D	19.75	501.67
E	25	635.03
F	26.5	673.13
G	6.5	165.10
H	4.0	101.60
I	2.5*	63.50*
J	4.0	101.60
K	2.5*	63.50*
L	12	304.81
M	10	254.01
N	0.5	12.70
O	Wide Slot	Wide Slot
P	9	228.61
Q	10.5	266.71
R	11	279.41
S	0.5	14.22
T	11.25	285.76

* Cast Iron, Hastelloy C and Stainless Steel Pumps

NOTE: Cast-In-Place Nipple Aluminum Pump Only. Female threaded on others.

OPTIONAL SCREEN BASE (Aluminum Pumps Only)



6017 Enterprise Drive
 Export, PA 15632
 Phone (724) 327-PUMP • Fax (724) 327-4300
 Toll Free (800) 843-8210

Consult factory for certified drawings.

Revised 4/97

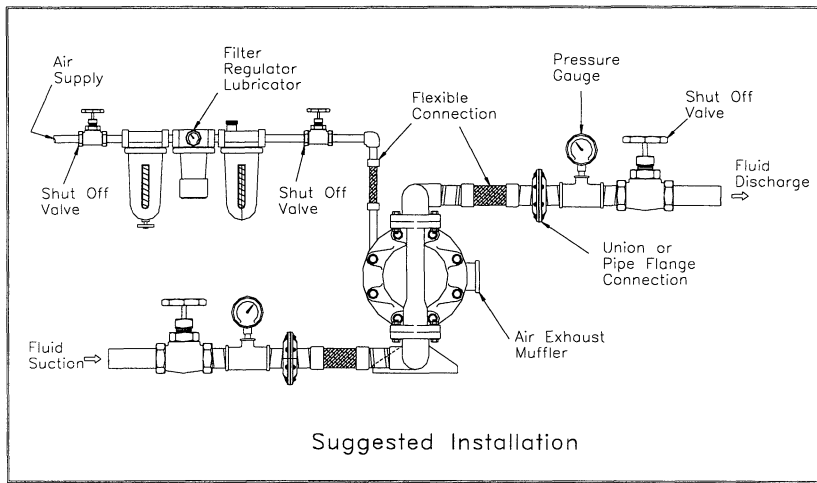

Caution
Do Not Exceed
125 psig air supply
pressure

Installation

The E2 pump comes with a footed base for easy mounting in permanent installations. The pump should be mounted in a vertical position. In permanent installations, the pump should be attached to plant piping using a flexible coupling on both the intake and discharge connections to reduce vibration to the pump and piping. To further reduce vibration, a surge suppresser next to the pump may be used.

Suction pipe size should be at least 2 inches in diameter or even larger if highly viscous fluid is to be pumped. If suction hose is used, it must be of a non-collapsible reinforced type. Discharge piping should be of at least 2 inches. It is critical, especially on the suction side of the pump, that all fittings and connections are air tight or pumping efficiency will be reduced and priming will be difficult.

The air supply line should be at least 1/2" in diameter. Make certain the supplying line and compressor are capable of supplying the required pressure and volume of air to operate the pump at the desired flow rate. The quality of the compressed air source should be considered. Air that is contaminated with moisture and dirt may result in erratic pump performance and increased maintenance cost as well as frequent process "down time" when the pump fails to operate properly.

Pump Operation

The pump is powered by compressed air. Compressed air is directed to the pump air chamber by the main air valve. The compressed air is separated from the fluid by a membrane called a diaphragm. The diaphragm in turn applies pressure on the fluid and forces it out of the pump discharge. While this is occurring, the opposite air chamber is de-pressurized and exhausted to atmosphere and fluid is drawn into the pump suction. The cycle again repeats, thus creating a constant reciprocating action which maintains flow through the pump. The flow is always in through the bottom suction connection and out through the top discharge connection. Since the air pressure acts directly on the diaphragms, the pressure applied to the fluid roughly approximates the air supply pressure supplied to the main air valve.

Trouble Shooting

The pump will not run, or runs slowly:

1. Examine the air inlet screen for dirt.
2. Check for a sticking air valve. Remove air valve from the pump and flush with solvent to remove dirt and debris. Check the Spool and Sleeve for nicks and scratches. If the spool is shiny instead of dull black, the spool and sleeve may be worn out and may need to be replaced. Clean all ports and airways and replace worn out gaskets and O-Rings.
3. Check Pilot Shaft and Main Shaft for scoring and scratches; replace if needed. Replace the Pilot Shaft and Main Shaft O-Rings if they are worn, flat or torn.

The pump runs, but little or no material flows:

1. Check for pump cavitation, slow the pump speed down to match the thickness of the material being pumped.
2. Look for sticking ball checks. If the material being pumped is not compatible with the ball material, the elastomer may swell. Replace the balls and seats with a compatible elastomer type.
3. Make sure all the suction line fittings and connections are air tight.

Air bubbles in pump discharge:

1. Look for ruptured diaphragm.
2. Check for suction leaks in pump manifolds and piping.

Material comes out of the pump air exhaust:

1. Inspect the diaphragm for rupture.
2. Check the tightness of the diaphragm plates to the pump shaft.

Safety Warnings

This equipment should only be used by experienced professional mechanics. Observe all safety warnings. Read all safety warnings and operating manuals before using or repairing this Air Operated Diaphragm Pump. (A.O.D. pump)

General Safety

This equipment may generate fluid pressures equal to the air supply pressure. Therefore DO NOT exceed the recommended air supply pressure. 100 psi (6.8 bar) for plastic pumps, 125 psi (8.5 bar) for metallic pumps.

ALWAYS wear safety glasses when using power tools to repair this equipment.

When the pumping system contains dangerous fluids wear protective gloves, glasses etc. when working on or around this equipment.

ALWAYS shut off the air supply and disconnect it from the pump before performing maintenance or repair to the pump.

Do Not put your face or body near the pump air exhaust while the pump is operating.

Bleed all pressure from discharge and suction lines before disconnecting the fluid suction or fluid discharge lines from the pump.

DO NOT operate a pump that is leaking, damaged, corroded or otherwise unable to contain the internal fluid pressure.

ALWAYS make sure safety shut off valves, regulators, pressure relief valves, gauges etc. are working properly before starting the pump.

DO NOT pump incompatible fluids through the pump. Consult your distributor or the factory if you are not sure of compatibility of fluids with the castings and elastomers.

Versa-Matic pumps are designed to operate on compressed air. Other compressed gases have not been tested and may be unsafe to use in A.O.D. pumps.

Before starting a pump make certain the discharge point of the piping system is clear and safe and all person have been warned to stand clear.

Equipment Misuse Hazard

General Safety

Any misuse of this equipment such as over pressurization, modifying parts, pumping incompatible chemicals and fluids, using worn or damaged parts or using gasses other than compressed air to power the pump is not recommended. Any of these circumstance could result in splashing or spraying into the eyes, skin or possible serious bodily injury, fire, explosion or property damage.

Over pressurization

Never exceed the operating pressure recommended for the model pump being used.

Noise

Wear Proper Ear protection when working or standing near A.O.D. pumps. IT IS recommended that a Air Exhaust Muffler is used on this equipment at all time.

Installation Hazards

Do not submerge the pump in liquids that are incompatible with the wetted or non-wetted parts of the pump. If installing in a submerged location extend the air exhaust port above the liquid surface with suitable pipe or hose.

Route exhaust line to safe location away from people and install a Air Exhaust Muffler.

Pump Diaphragm Failure

A.O.D. pumps utilize a elastomeric membrane to separate the pumping liquid from the air supply. When this membrane ruptures pumping fluid may be expelled from the air exhaust port. Always pipe the air exhaust port to a safe location or suitable container if dangerous or volatile liquids are being pumped.

Installation

Never allow the piping system to be supported by the pump manifolds or valve housing. The manifolds and valve housings are not designed to support any structural weight and failure of the pump may result. The use of flexible piping connections is highly recommended.

Temperature limits

Do not exceed the recommended operating temperatures of the pump or pump failure may result.

Moving Parts Hazard

The diaphragm plates (sometimes referred to as piston plates) located inside the pump on either side of the main shaft move when air pressure is supplied to the pump. Therefore, Never attempt to operate the pump with the liquid chambers removed. Moving parts inside the pump can pinch or seriously injure your fingers or other body parts.

Fire or Explosion Hazard

Static electricity can be created by the flow of fluid through the pump or by the reciprocating action of A.O.D. pumps. If the pump is not properly grounded, sparking may occur, and the system may become hazardous. Sparks can ignite fumes or vapor and cause an explosion.

If you experience static sparking or even a slight shock when using the pump do not continue to operate the pump until the pump is properly grounded.

Proper Grounding

Pump, Valves, Discharge and supply lines as well as containers must be grounded. These items must be grounded when handling flammable fluids and when static electricity discharge is a hazard.

1. To ground plastic pumps connect a ground wire to all metallic clamps as well as the air valve body & piston assembly. The ground wire should be connected to a suitable ground location. (figure 1)
2. To ground metallic pumps, connect a ground wire to any accessible point of attachment such as clamp band bolt or mounting base.

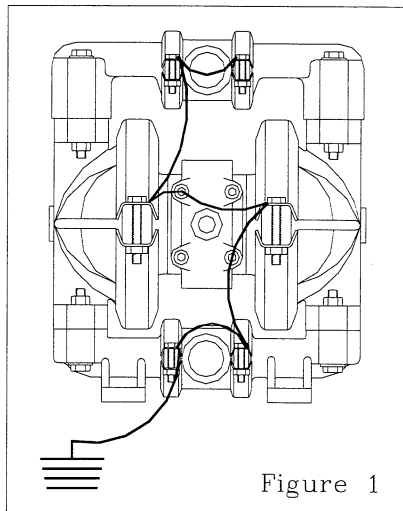

Figure 1

Sound Level Ratings, dB(A)

The following table lists the sound level ratings of Versa-Matic Pumps equipped with factory installed Air Exhaust Mufflers. The readings were obtained with a Pacer Industries model SL-120, sound level indicator "A" scale. Readings were made at a distance of 1 meter from the pump and a height of 1.6 meters above the floor. It is assumed the pumps will be installed at floor level.

Pump Series	dB(A) reading
E5, 1/2" pump	71.7 dB(A)
E1, 1" pump	76.5 dB(A)
V4, 1-1/4" pump	76.5 dB(A)
V2, 2" pump	74.3 dB(A)
V3, 3" pump	67.1 dB(A)
E2, 2" pump	74.3 dB(A)
E3, 3" pump	67.1 dB(A)
E4, 1-1/4" pump	76.5 dB(A)

Temperature Limitations

Maximum Temperature limitation are based on mechanical stress only. Certain chemicals will reduce the maximum safe operating temperatures of A.O.D pumps. Consult your dealer or Chemical Resistance guide for compatibility and temperature limits.

Metallic Pumps

Metallic pumps can operate past 212°F (100°C). However if you are operating above these limits, consult the factory for assistance.*

Plastic Pumps

Plastic pumps can operate within the following limits:*

Polypropylene:	32°(0°C) to 175°F(79°C)
PVDF (Kynar):	10°F(-12°C) to 225°F(107°C)
Teflon PFA:	-20°F(-29°C) to 200°F(93°C)

*Do not exceed the maximum temperature limits of the elastomer type (diaphragms, balls, seats) that is used in your pump.

Temperature limits of various elastomer types

Neoprene:	0°F(-18°C) to 200°F(93°C)
Buna-N:	10°F(-12°C) to 180°F(82°C)
Nordel:	-60°F(-51°C) to 280°F(138°C)
Viton:	-40°F(-40°C) to 350°F(176°C)
Teflon:	40°F(4°C) to 220°F(105°C)
Polyurethane:	10°F(-12°C) to 170°F(77°C)
XL TPE:	-20°F(-29°C) to 300°F(149°C)
FDA Hytrel:	-20°F(-29°C) to 220°F(104°C)

E2, 2" Pumps, Rubber Elastomers Assembly Drawing & Parts Lists

Item	Description	Qty	Pump Model Number				
			E2BA....	E2AA....	E2CA....	E2SA....	E2HA....
	Center Section Assembly (Items 1-27)	1	P24-100				
1	Air Chamber	2	P24-101				
2							
3	Shaft	1	P24-103				
4	Pilot Shaft	1	P24-104				
5	Bushing, Threaded	2	P24-105				
6	Pilot Valve Spacer Rings	5	P24-106				
7	Pilot Valve O-Rings	6	P24-107				
8	Stop Nut	2	P24-108				
9	Bolt	8	P24-110				
10	Valve Assembly (Items 11-21)	1	P34-200				
11	Air Valve & Sleeve Assembly	1	P34-211				
12	Gasket, Valve Body	1	P24-202				
13	Glyd-Ring Assembly	2	P34-204F				
14	Spool Assembly	1	P34-204				
15	Gasket, End Cap	2	P24-205				
16	Plastic Elbow	1	PV220G				
17	Muffler	1	VM-0750				
18	Cap Screw	13	P24-208				
19	Air Valve Screen	1	P24-210				
20							
21	End Cap Assembly	2	P34-300				
22	Center Block Assembly (Item 23-26)	1	P24-400				
23	Center Block	1	P24-401				
24	Bearing Sleeve	1	P24-402				
25	Center Block O-Ring	2	P24-403				
26	Center Block Gasket	2	P24-109				
27	O-Ring	2	V221D (use with V224 Diaphragm)				
28	Inner Diaphragm Plate	2	*V221B				
			**V226B				
29	Outer Diaphragm Plate	2	*VB221	*WVB221	*SVB221	*HVB221	
			**VB226	**SVB226	**SVB226	**HVB226	
30	Water Chamber	2	V235	WV235	SV235	HV235	
31	Discharge Manifold	1	V236	WV236	SV236	HV236	
32	Inlet Suction Manifold-Footed	1	N/R	V237F	WV237F	SV237F	HV237F
33	Inlet Housing-Screened	1	V237	N/R			
34	Screen for P/N V237	1	V238	N/R			
35	Bolt	3	V238A	N/R			
36	Hook-Up-Cover	1	V242	N/R			
37	Large Clamp Assembly, SS	2	V230-1		SV230-1		
38	Small Clamp Assembly, SS	4	V239		SV239		
39	Diaphragm (2 Styles Available)	2	Versa-Rugged V224 ††				
			Versa-Dome V225 ††				
40	Valve Seat	4	V240 ††				
41	Valve Ball	4	V241 ††				

†† Material Options Choose the correct material code suffix (example V224N designates a Neoprene Diaphragm)

N – Neoprene	XL – XL Thermomatic
BN – Buna-N	ND – Nordel
V – Viton	FG – Hytrel

* Indicates parts used with V224, Versa-Rugged Diaphragms

** Indicates parts used with V225, Versa-Dome Diaphragms

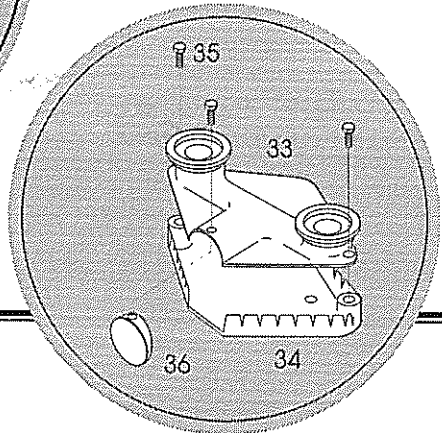
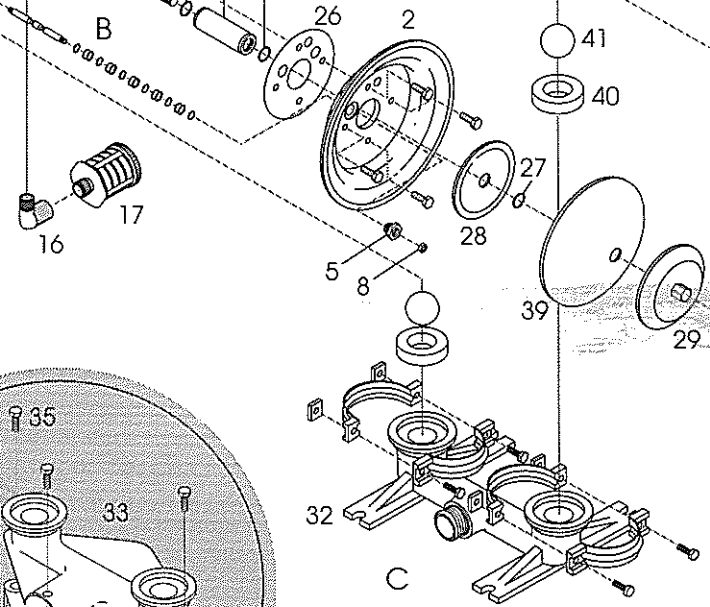
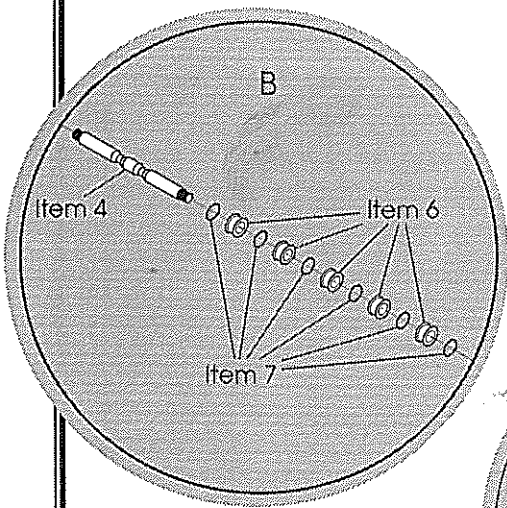
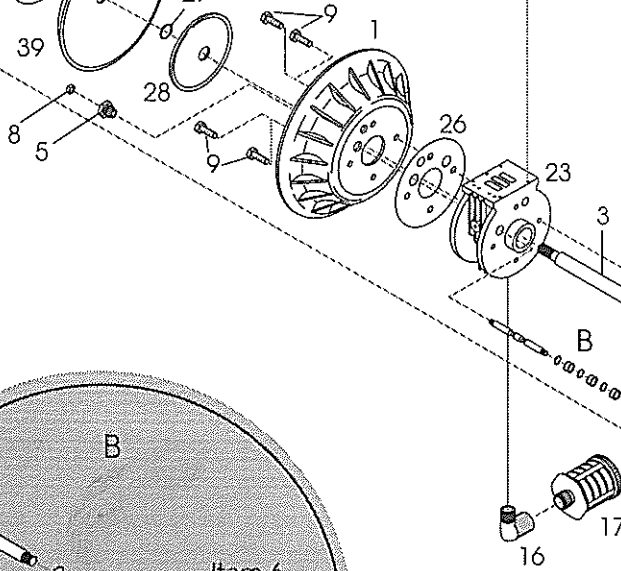
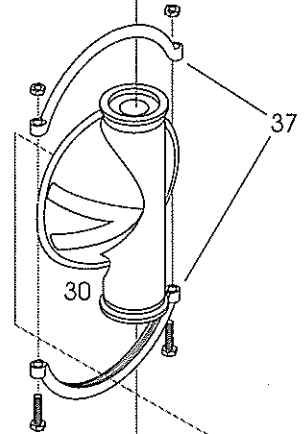
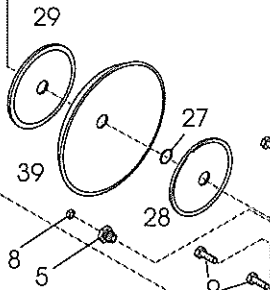
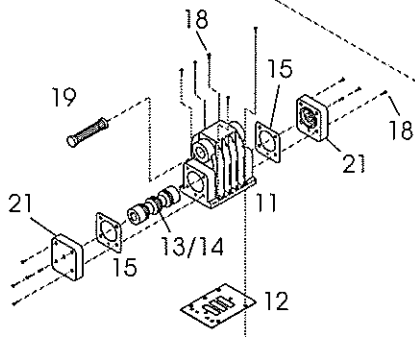
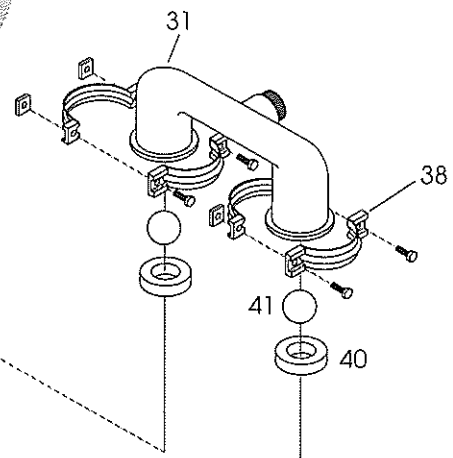
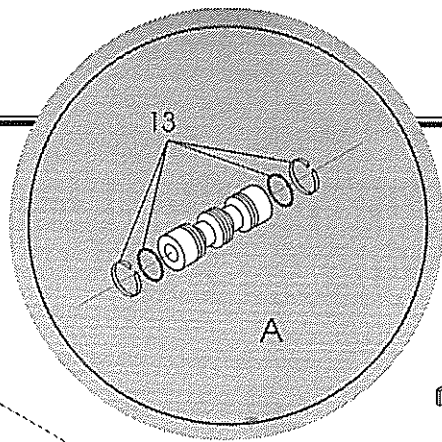

Revised 3/97

E2, 2" Pumps, Teflon Elastomers Assembly Drawing & Parts Lists

Item	Description	Qty	Pump Model Number			
			E2AA5T550 Aluminum	E2CA5T550 Cast Iron	E2SA5T550 Stainless Stl	E2HA5T550 Hastelloy C
	Center Section Assembly (Items 1-27)	1	P24-100			
1	Air Chamber	2	P24-101			
2						
3	Shaft	1	P24-102			
4	Pilot Shaft	1	P24-104			
5	Bushing, Threaded	2	P24-105			
6	Pilot Valve Spacer Rings	5	P24-106			
7	Pilot Valve O-Rings	6	P24-107			
8	Stop Nut	2	P24-108			
9	Bolt	8	P24-110			
10	Valve Assembly (Items 11-21)	1	P34-200			
11	Air Valve & Sleeve Assembly	1	P34-211			
12	Gasket, Valve Body	1	P24-202			
13	Glyd-Ring Assembly	2	P34-204F			
14	Spool Assembly	1	P34-204			
15	Gasket, End Cap	2	P24-205			
16	Plastic Elbow	1	PV220G			
17	Shaft Stud	2	V221F			
18	Cap Screw	13	P24-208			
19	Air Valve Screen	1	P24-210			
20	Muffler	1	VM-0750			
21	End Cap Assembly	2	P34-300			
22	Center Block Assembly (Item 23-26)	1	P24-400			
23	Center Block	1	P24-401			
24	Bearing Sleeve	1	P24-402			
25	Center Block O-Ring	2	P24-403			
26	Center Block Gasket	2	P24-109			
27	Inner Diaphragm Plate		V221TI			
28	Outer Diaphragm Plate	2	V221TO	SV221TO		HV221TO
29	Water Chamber	2	V235	WV235	SV235	HV235
30	Discharge Manifold	1	V236	WV236	SV236	HV236
31	Inlet Suction Manifold-Footed	1	V237F	WV237F	SV237F	HV237F
32	Large Clamp Assembly, SS	2	V230-1		SV230-1	
33	Small Clamp Assembly, SS	4	V239		SV239	
34	Teflon Diaphragm	2	See Chart Below			
35a	Back-Up Diaphragm	2	See Chart Below			
35b	Gortex Tape Kit	1	V224TFG-KIT (Not Shown)			
36	Valve Seat	4	V240A	V240CS	SV240	HV240
37	Valve Seat O-Ring	4	V240T			
38	Valve Ball	4	V241TF			
39	Bumper Washer	2	P24-501			

Diaphragm Selection Chart:

For E2 Pump Models fitted with Tef-Matic™ Diaphragms, use Part No. V224TF and Back-Up Diaphragm Part Number V224TFB
 For E2 Pump Models fitted with Tef-Matic™ Diaphragms, use Part No. V224TF and Back-Up Diaphragm Part Number V224TFB

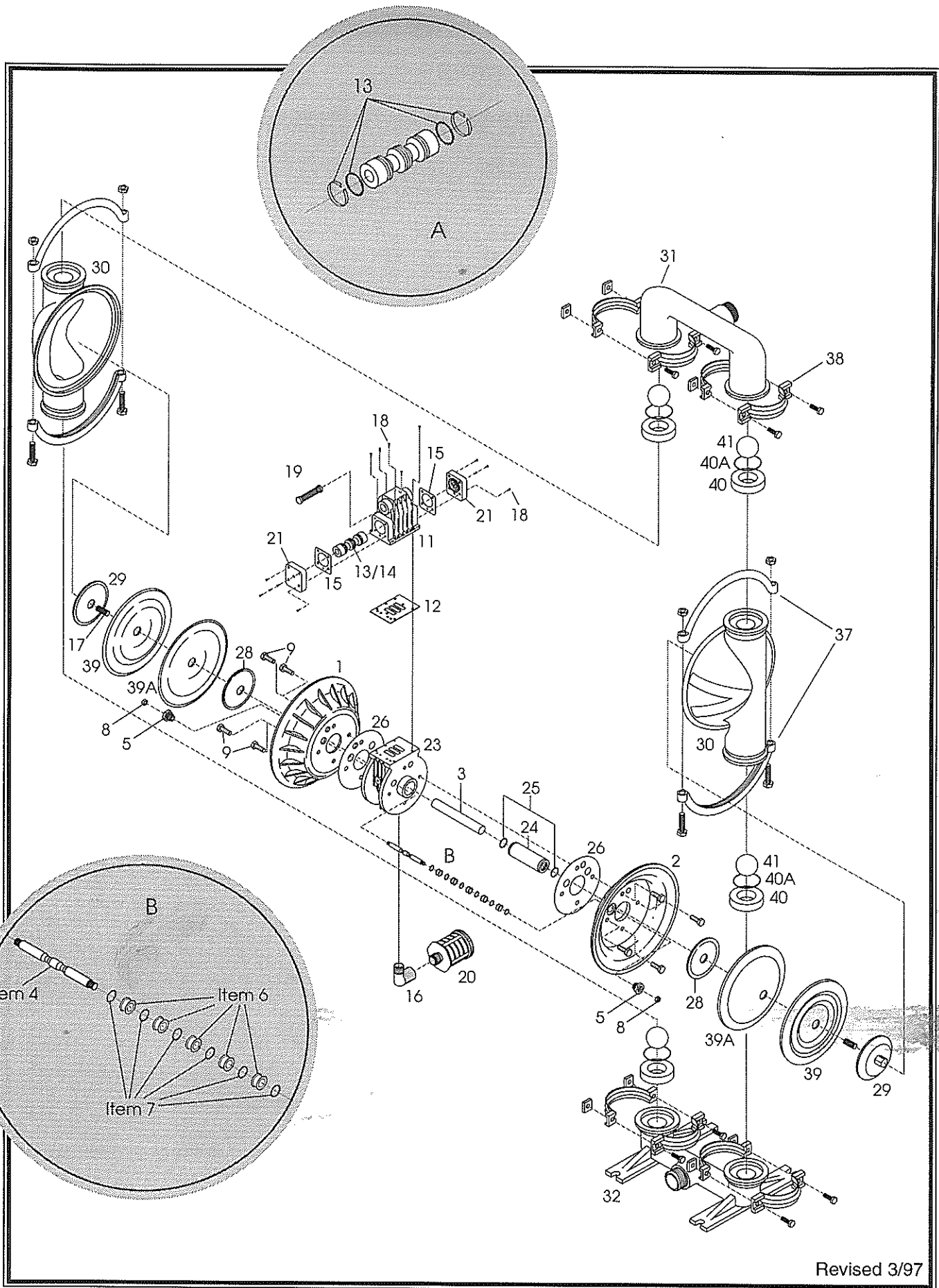

Revised 3/97

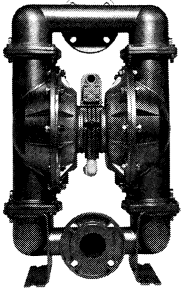

ELIMA-MATIC® ANTI-STALLING PUMPS

- Virtually eliminates pump stalling caused by air valve system freeze-ups
- Anti-stalling, non-icing, lubrication-free air valve system.
- Available in 1/2", 1", 1 1/4", 2" and 3" sizes
- Wide selection of materials of construction—including 1/2", 1" and 2" plastic models

PLASTIC PUMPS FOR SOLVENTS AND CHEMICALS

- Exceptional corrosion resistance
- Wide selection of materials of construction for wetted and non-wetted parts
- Leak free bolted construction
- Also available in 1/2", 1", 1 1/2" and 2" with the Elima-Matic anti-stalling air valve system

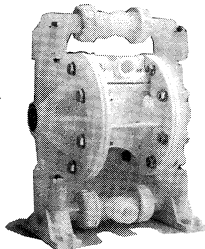

Elima-Matic 2:1 High Pressure Pump

- Cast in 150lbs ANSI/DIN flanges
- Constructed of 316 stainless steel
- Can create discharge pressure over 200 psi
- Leak-Free bolted design

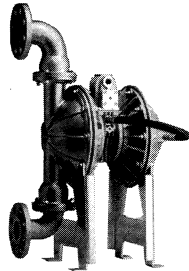

FOOD AND SANITARY PUMPS

SANITARY PUMPS

- FDA approved for use with milk and milk products
- Constructed of 316 stainless steel
- Surface finish of 32 micro-inch or better
- Removable ball cages
- Easy clean Tri-clamp® connections

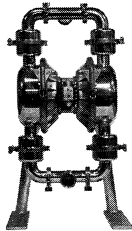

FOOD PROCESSING PUMPS

- Constructed of 316 stainless steel
- FDA approved
- Tri-clamp® connections
- Over-sized clamp wing nuts for disassembly

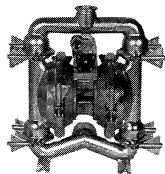

VERSA-MATIC PUMP

6017 Enterprise Drive
Export, PA 15632-8969
(724) 327-7867 • Fax: (724) 327-4300

www.versamatic.com

** Life cycle may vary according to extreme start-up conditions, chemicals and abrasive fluids. To prolong diaphragm life, Versa-Matic recommends a gradual increase in air supply on pump start-up.*

Elima-Matic®, Versa-Dome®, Versa-Matic® and VR® are registered trademarks or trademarks of Versa-Matic Tool, Inc. Some Versa-Matic Tool, Inc. products are subject to patent pending applications and issued patents, Elima-Matic U.S. Patent No. 5,326,234. Hytrel®, Nordel®, Teflon® and Viton® are registered trademarks of DuPont. Tri-Clamp® is a registered Trademark of the Tri-Clamp, Inc. Wilden® is a registered Trademark of Wilden Pump and Engineering Co.

VERSA-DOME® DIAPHRAGMS

- The simple, smooth design eliminates complex angles allowing for 3 to 4 times the flex life of standard diaphragms.
- So flexible they can be installed and removed without the use of pry bars
- Has lower start up pressure than standard diaphragm.
- Available Neoprene, Buna-N, Hytrel, Nordel®, Viton® and XL.
- For use in Versa-Matic and Wilden 1/2", 2", 3" pumps.

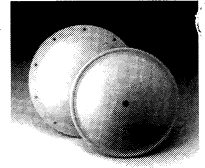

VERSA-TUFF TEFLON DIAPHRAGMS

- Single piece diaphragm combining the chemical resistance of Teflon with the flex life of rubber.*
- Three times the burst strength of ordinary Teflon overlays
- More flexible and 100% bonded to the reinforced rubber backing
- Diaphragms can be placed into Wilden® M4 and M8 pumps

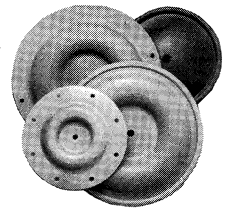

GENUINE VERSA-MATIC REPLACEMENT PARTS AND RETRO FIT CENTER SECTIONS

- Upgrade V-series and Wilden® M4, M8, and M15 pumps with an Elima-Matic retro fit center section
- For complete repair of Versa-Matic pumps and Wilden® M4, M8 and M15 metallic pumps
- Cost-saving elastomer kits for any Versa-Matic pump or Wilden® M1, M2, M4, M8 and M15 pumps
- Diaphragm and elastomer repair kits available in Buna-N, Neoprene, Nordel®, Teflon®, Viton®, Thermo Plastics Hytrel®, and XL

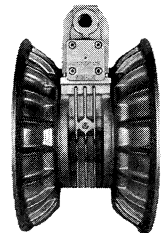

Your local authorized distributor:

