

CR, CRN

- Ⓜ Installation and operating instructions
- Ⓝ Montage- und Betriebsanleitung
- ⓕ Notice d'installation et d'entretien
- Ⓡ Istruzioni di installazione e funzionamento
- ⓔ Instrucciones de instalación y funcionamiento
- Ⓟ Instruções de instalação e funcionamento
- Ⓜ Οδηγίες εγκατάστασης και λειτουργίας
- Ⓝ Installatie- en bedieningsinstructies
- Ⓢ Monterings- och driftsinstruktion
- ⓕ Asennus- ja käyttöohjeet
- Ⓝ Monterings- og driftsinstruktion



Declaration of Conformity

We **GRUNDFOS** declare under our sole responsibility that the products **CR** and **CRN**, to which this declaration relates, are in conformity with the Council Directives on the approximation of the laws of the EC Member States relating to

- Machinery (98/37/EC).
Standard used: EN 292.
- Electromagnetic compatibility (89/336/EEC).
Standards used: EN 61 000-6-2 and EN 61 000-6-3.
- Electrical equipment designed for use within certain voltage limits (73/23/EEC) [95].
Standards used: EN 60 335-1 and EN 60 335-2-51.

Konformitätserklärung

Wir **GRUNDFOS** erklären in alleiniger Verantwortung, daß die Produkte **CR** und **CRN**, auf die sich diese Erklärung bezieht, mit den folgenden Richtlinien des Rates zur Angleichung der Rechtsvorschriften der EG-Mitgliedstaaten übereinstimmen:

- Maschinen (98/37/EG).
Norm, die verwendet wurde: EN 292.
- Elektromagnetische Verträglichkeit (89/336/EWG).
Normen, die verwendet wurden: EN 61 000-6-2 und EN 61 000-6-3.
- Elektrische Betriebsmittel zur Verwendung innerhalb bestimmter Spannungsgrenzen (73/23/EWG) [95].
Normen, die verwendet wurden: EN 60 335-1 und EN 60 335-2-51.

Déclaration de Conformité

Nous **GRUNDFOS** déclarons sous notre seule responsabilité que les produits **CR** et **CRN** auxquels se réfère cette déclaration sont conformes aux Directives du Conseil concernant le rapprochement des législations des Etats membres CE relatives à

- Machines (98/37/CE).
Standard utilisé: EN 292.
- Compatibilité électromagnétique (89/336/CEE).
Standards utilisés: EN 61 000-6-2 et EN 61 000-6-3.
- Matériel électrique destiné à employer dans certaines limites de tension (73/23/CEE) [95].
Standards utilisés: EN 60 335-1 et EN 60 335-2-51.

Dichiarazione di Conformità

Noi **GRUNDFOS** dichiariamo sotto la nostra esclusiva responsabilità che i prodotti **CR** e **CRN**, ai quali questa dichiarazione si riferisce, sono conformi alle Direttive del consiglio concernenti il ravvicinamento delle legislazioni degli Stati membri CE relative a

- Macchine (98/37/CE).
Standard usato: EN 292.
- Compatibilità elettromagnetica (89/336/CEE).
Standard usati: EN 61 000-6-2 e EN 61 000-6-3.
- Materiale elettrico destinato ad essere utilizzato entro certi limiti di tensione (73/23/CEE) [95].
Standard usati: EN 60 335-1 e EN 60 335-2-51.

Declaración de Conformidad

Nosotros **GRUNDFOS** declaramos bajo nuestra única responsabilidad que los productos **CR** y **CRN** a los cuales se refiere esta declaración son conformes con las Directivas del Consejo relativas a la aproximación de las legislaciones de los Estados Miembros de la CE sobre

- Máquinas (98/37/CE).
Norma aplicada: EN 292.
- Compatibilidad electromagnética (89/336/CEE).
Normas aplicadas: EN 61 000-6-2 y EN 61 000-6-3.
- Material eléctrico destinado a utilizarse con determinados límites de tensión (73/23/CEE) [95].
Normas aplicadas: EN 60 335-1 y EN 60 335-2-51.

Declaração de Conformidade

Nós **GRUNDFOS** declaramos sob nossa única responsabilidade que os produtos **CR** e **CRN** aos quais se refere esta declaração estão em conformidade com as Directivas do Conselho das Comunidades Europeias relativas à aproximação das legislações dos Estados Membros respeitantes à

- Máquinas (98/37/CE).
Norma utilizada: EN 292.
- Compatibilidade electromagnética (89/336/CEE).
Normas utilizadas: EN 61 000-6-2 e EN 61 000-6-3.
- Material eléctrico destinado a ser utilizado dentro de certos limites de tensão (73/23/CEE) [95].
Normas utilizadas: EN 60 335-1 e EN 60 335-2-51.

Δήλωση Συμμόρφωσης

Εμείς η **GRUNDFOS** δηλώνουμε με αποκλειστικά δική μας ευθύνη ότι τα προϊόντα **CR** και **CRN** συμμορφώνονται με την Οδηγία του Συμβουλίου επί της σύγκλισης των νόμων των Κρατών Μελών της Ευρωπαϊκής Ένωσης σε σχέση με τα

- Μηχανήματα (98/37/ΕC).
Πρότυπο που χρησιμοποιήθηκε: EN 292.
- Ηλεκτρομαγνητική συμβατότητα (89/336/ΕΕC).
Πρότυπα που χρησιμοποιήθηκαν: EN 61 000-6-2 και EN 61 000-6-3.
- Ηλεκτρικές συσκευές σχεδιασμένες για χρήση εντός ορισμένων ορίων ηλεκτρικής τάσης (73/23/ΕΕC) [95].
Πρότυπα που χρησιμοποιήθηκαν: EN 60 335-1 και EN 60 335-2-51.

Overeenkomstigheidsverklaring

Wij **GRUNDFOS** verklaren geheel onder eigen verantwoordelijkheid dat de producten **CR** en **CRN** waarop deze verklaring betrekking heeft in overeenstemming zijn met de Richtlijnen van de Raad inzake de onderlinge aanpassing van de wetgevingen van de Lid-Staten betreffende

- Machines (98/37/EG).
Norm: EN 292.
- Elektromagnetische compatibiliteit (89/336/EEG).
Normen: EN 61 000-6-2 en EN 61 000-6-3.
- Elektrisch materiaal bestemd voor gebruik binnen bepaalde spanningsgrenzen (73/23/EEG) [95].
Normen: EN 60 335-1 en EN 60 335-2-51.

Försäkran om överensstämmelse

Vi **GRUNDFOS** försäkrar under ansvar, att produkterna **CR** och **CRN**, som omfattas av denna försäkran, är i överensstämmelse med Rådets Direktiv om inbördes närmande till EU-medlemsstaternas lagstiftning, avseende

- Maskinell utrustning (98/37/EC).
Använd standard: EN 292.
- Elektromagnetisk kompatibilitet (89/336/EC).
Använda standarder: EN 61 000-6-2 och EN 61 000-6-3.
- Elektrisk material avsedd för användning inom vissa spänningsgränser (73/23/EC) [95].
Använda standarder: EN 60 335-1 och EN 60 335-2-51.

Vastaavuusvakuutus

Me **GRUNDFOS** vakuutamme yksin vastuullisesti, että tuotteet **CR** ja **CRN**, jota tämä vakuutus koskee, noudattavat direktiivejä jotka käsittelevät EY:n jäsenvaltioiden koneellisia laitteita koskevien lakien yhdenmukaisuutta seur.:

- Koneet (98/37/EY).
Käytetty standardi: EN 292.
- Elektromagneettinen vastaavuus (89/336/EY).
Käytetyt standardit: EN 61 000-6-2 ja EN 61 000-6-3.
- Määrättyjen jänniterajojen puitteissa käytettävät sähköiset laitteet (73/23/EY) [95].
Käytetyt standardit: EN 60 335-1 ja EN 60 335-2-51.

Overensstemmelseserklæring

Vi **GRUNDFOS** erklærer under ansvar, at produkterne **CR** og **CRN**, som denne erklæring omhandler, er i overensstemmelse med Rådets direktiver om indbyrdes tilnærmelse til EF medlemsstaternes lovgivning om

- Maskiner (98/37/EF).
Anvendt standard: EN 292.
- Elektromagnetisk kompatibilitet (89/336/EØF).
Anvendte standarder: EN 61 000-6-2 og EN 61 000-6-3.
- Elektrisk materiel bestemt til anvendelse inden for visse spændingsgrænser (73/23/EØF) [95].
Anvendte standarder: EN 60 335-1 og EN 60 335-2-51.

Bjerringbro, 1st September 2003

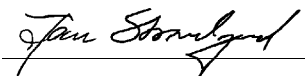

Jan Strandgaard
Technical Manager

CR, CRN

Installation and operating instructions	Page	4	GB
Montage- und Betriebsanleitung	Seite	9	D
Notice d'installation et d'entretien	Page	15	F
Istruzioni di installazione e funzionamento	Pag.	21	I
Instrucciones de instalación y funcionamiento	Pág.	26	E
Instruções de instalação e funcionamento	Pág.	31	P
Οδηγίες εγκατάστασης και λειτουργίας	Σελίδα	37	GR
Installatie- en bedieningsinstructies	Pag.	43	NL
Monterings- och driftsinstruktion	Sida	48	S
Asennus- ja käyttöohjeet	Sivu	53	SF
Monterings- og driftsinstruktion	Side	58	DK

CONTENTS

	Page
1. Handling	4
2. Type designation	4
2.1 Pump key for CR, CRN 2, 4, 8 and 16	4
3. Applications	4
4. Technical data	4
4.1 Ambient temperature	4
4.2 Liquid temperature	4
4.3 Maximum permissible operating pressure and liquid temperature for the shaft seal	4
4.4 Minimum inlet pressure	5
4.5 Maximum inlet pressure	5
4.6 Electrical data	5
4.7 Frequency of starts and stops	5
4.8 Dimensions and weights	5
4.9 Sound level	5
5. Installation	5
6. Coupling adjustment	6
7. Electrical connection	6
7.1 Frequency converter operation	6
8. Start-up	7
9. Maintenance	7
10. Frost protection	7
11. Service	8
12. Fault finding chart	8
13. Disposal	8



Before beginning installation procedures, these installation and operating instructions should be studied carefully. The installation and operation should also be in accordance with local regulations and accepted codes of good practice.

1. Handling



The motors of the CR, CRN 2, 4, 8 and 16 pumps are supplied with lifting eyes which must not be used for lifting the entire pump.

When the entire pump is to be lifted, observe the following:

- CR, CRN 2, 4, 8 and 16 pumps fitted with GRUNDFOS MG motors should be lifted in the pump head by means of straps or the like.
- For other motor makes, it is recommended to lift the pump in the pump head by means of straps.

2. Type designation

2.1 Pump key for CR, CRN 2, 4, 8 and 16

Example	CR 8 - 30 / 2 - X - X - X - XXXX
Pump range: CR, CRN	
Nominal flow rate in m ³ /h	
Number of stages x 10	
Number of impellers (is only used if the pump has fewer impellers than chambers)	
Code for pump version	
Code for pipework connection	
Code for materials	
Code for shaft seal and rubber pump parts	

3. Applications

GRUNDFOS multistage in-line centrifugal pumps, types CR and CRN, are designed for a wide range of applications.

Pumped liquids

Thin, non-explosive liquids, not containing solid particles or fibres. The liquid must not attack the pump materials chemically. When pumping liquids with a density and/or viscosity higher than that of water, motors with correspondingly higher outputs must be used, if required.

CR, CRN

For liquid transfer, circulation and pressure boosting of cold or hot clean water.

CRN

In systems where all parts in contact with the liquid must be made of stainless steel, CRN pumps must be used.

4. Technical data

4.1 Ambient temperature

Maximum +40°C.

If the ambient temperature exceeds +40°C, the motor output (P2) must be reduced, see fig. 1.

Fig. 1

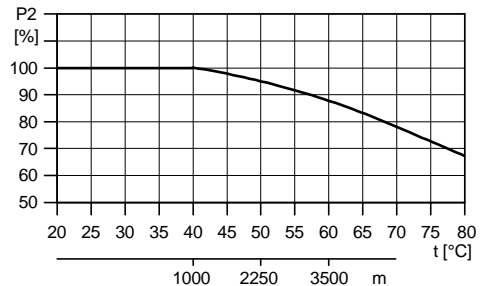

TM00 2189 4298

4.2 Liquid temperature

Pump type	Liquid temperature
CR, CRN 2, 4, 8 and 16	-20°C to +120°C

See also fig. A, page 63, which indicates the relationship between liquid temperature and maximum permissible operating pressure.

Note: The maximum permissible operating pressure and liquid temperature ranges apply to the pump only.

4.3 Maximum permissible operating pressure and liquid temperature for the shaft seal

Fig. 2

CR, CRN 2, 4, 8 and 16:

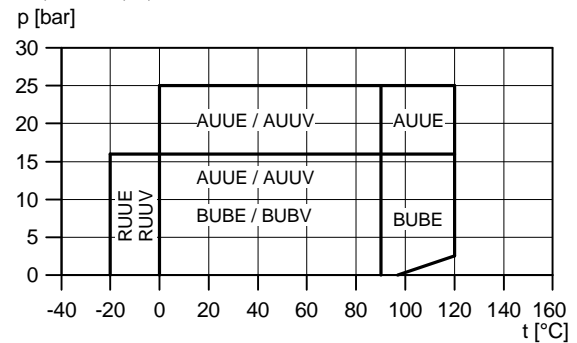

TM01 1922 4500

4.4 Minimum inlet pressure

Fig. 3

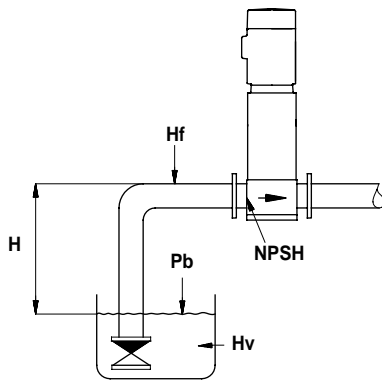

TM01 1242 4097

The maximum suction lift "H" in metres head can be calculated as follows:

$$H = p_b \times 10.2 - NPSH - H_f - H_v - H_s$$

p_b = Barometric pressure in bar.
(Barometric pressure can be set to 1 bar).
In closed systems, p_b indicates the system pressure in bar.

NPSH = Net Positive Suction Head in metres head
(to be read from the NPSH curve on page 69 at the highest flow the pump will be delivering).

H_f = Friction loss in suction pipe in metres head at the highest flow the pump will be delivering.

H_v = Vapour pressure in metres head, see fig. E on page 66. t_m = Liquid temperature.

H_s = Safety margin = minimum 0.5 metres head.

If the calculated "H" is positive, the pump can operate at a suction lift of maximum "H" metres head.

If the calculated "H" is negative, an inlet pressure of minimum "H" metres head is required. There must be a pressure equal to the calculated "H" during operation.

Example:

$p_b = 1$ bar.
Pump type: CR 16, 50 Hz.
Flow rate: 16 m³/h.
NPSH (from page 69): 1.5 metres head.
 $H_f = 3.0$ metres head.
Liquid temperature: +60°C.
 H_v (from fig. E, page 66): 2.1 metres head.
 $H = p_b \times 10.2 - NPSH - H_f - H_v - H_s$ [metres head].
 $H = 1 \times 10.2 - 1.5 - 3.0 - 2.1 - 0.5 = 3.1$ metres head.

This means that the pump can operate at a suction lift of maximum 3.1 metres head.

Pressure calculated in bar: 3.1 x 0.0981 = 0.30 bar.

Pressure calculated in kPa: 3.1 x 9.81 = 30.4 kPa.

4.5 Maximum inlet pressure

Figure B, page 64, shows the maximum permissible inlet pressure. However, the actual inlet pressure + pressure when the pump is running against a closed valve must always be lower than the "maximum permissible operating pressure".

If the system and the pumps are to be pressure-tested at a pressure higher than that stated in fig. B, page 64, the pump shaft must be locked to prevent axial movement.

4.6 Electrical data

See motor nameplate.

4.7 Frequency of starts and stops

Motors up to 4 kW: Maximum 100 times per hour.
Other motors: Maximum 20 times per hour.

4.8 Dimensions and weights

Dimensions: See fig. C, page 65.

Weights: See label on the packing.

4.9 Sound level

See fig. D, page 66.

5. Installation

The pump can be installed vertically or horizontally, see fig. 4. Ensure that an adequate supply of cool air reaches the motor cooling fan. However, the motor must never fall below the horizontal plane.

Fig. 4

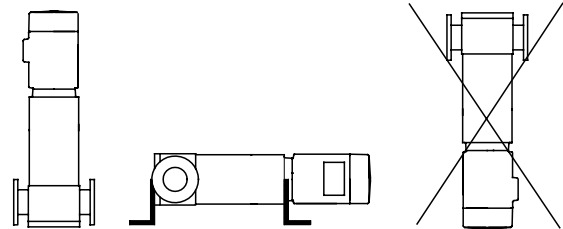

TM01 1241 4097

Arrows on the pump base show the direction of flow of liquid through the pump.

Figure C, page 65, shows the dimensions of the base as well as the diameter and the position of the foundation bolt holes.

To minimize possible noise from the pump, it is advisable to fit expansion joints either side of the pump and anti-vibration mountings between foundation and pump.

Port-to-port lengths and pipework connections appear from fig. C, page 65.

Isolating valves should be fitted either side of the pump to avoid draining the system if the pump needs to be cleaned, repaired or replaced.

Install the pipes so that air locks are avoided, especially on the suction side of the pump. Correct pipework shown in fig. 5.

Fig. 5

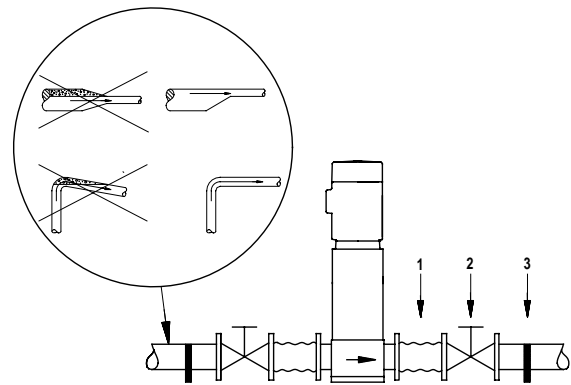

TM01 0900 3997

Pos. no.	Description	Function
1	Expansion joint	Reduces noise and absorbs vibrations and expansion.
2	Isolating valve	Enables easy service of the pump.
3	Pipe hanger	Supports pipe and absorbs distortion and strain.

Note: The pump must always be protected against backflow by means of a non-return valve (foot valve).

In the case of installations in which the discharge pipe slopes downwards away from the pump and there is a risk of siphon effect and in installations which must be protected against backflow of unclean liquids, a vacuum valve must be fitted close to the pump, see fig. 6.

Fig. 6

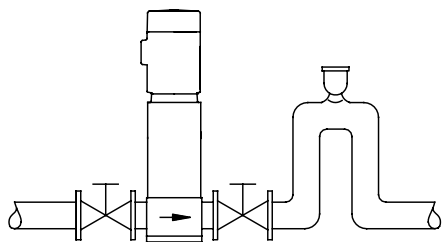

Minimum flows:

Pump type	Liquid temperature		
	Up to +80°C	+80°C +120°C	+120°C +150°C (only special version)
CR, CRN 2	0.2 m ³ /h	0.5 m ³ /h	-
CR, CRN 4	0.4 m ³ /h	1.0 m ³ /h	-
CR, CRN 8	0.8 m ³ /h	2.0 m ³ /h	-
CR, CRN 16	1.6 m ³ /h	4.0 m ³ /h	-

Note: The pump must never operate against a closed discharge valve.

6. Coupling adjustment

For adjustment of coupling in CR, CRN 2 and 4, see fig. F, page 67.

For adjustment of coupling in CR, CRN 8 and 16, see fig. G, page 68.

7. Electrical connection

The electrical connection should be carried out by an authorized electrician in accordance with local regulations.



Before removing the terminal box cover and before any removal/dismantling of the pump, make sure that the electricity supply has been switched off.

The pump must be connected to an external mains switch with a minimum contact gap of 3 mm in all poles.

The operating voltage and frequency are marked on the motor nameplate. Make sure that the motor is suitable for the electricity supply on which it will be used.

Single-phase GRUNDFOS motors incorporate a thermal switch and require no additional motor protection.

Three-phase motors must be connected to a motor starter.

The terminal box can be turned to four positions, in 90° steps:

1. If necessary, remove the coupling guards. Do *not* remove the coupling.
2. Remove the bolts securing the motor to the pump.
3. Turn the motor to the required position.
4. Replace and tighten the bolts.
5. Replace the coupling guards.

The electrical connection should be carried out as shown in the diagram inside the terminal box cover.

7.1 Frequency converter operation

Motors supplied by GRUNDFOS:

All three-phase motors supplied by GRUNDFOS can be connected to a frequency converter.

Dependent on the frequency converter type, this may cause increased acoustic noise from the motor. Furthermore, it may cause the motor to be exposed to detrimental voltage peaks.

Note: GRUNDFOS motors types MG 71 and MG 80 as well as MG 90 (1.5 kW, 2-pole), all for supply voltages up to and including 440 V (see motor nameplate), must be protected against voltage peaks higher than 650 V (peak value) between the supply terminals.

It is recommended to protect all other motors against voltage peaks higher than 850 V.

The above disturbances, i.e. both increased acoustic noise and detrimental voltage peaks, can be eliminated by fitting an LC filter between the frequency converter and the motor.

For further information, please contact the frequency converter or motor supplier.

Other motor makes than those supplied by GRUNDFOS:

Please contact GRUNDFOS or the motor manufacturer.





8. Start-up

Note: Do not start the pump until it has been filled with liquid and vented.

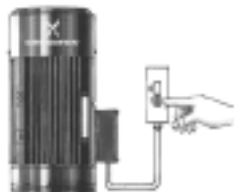
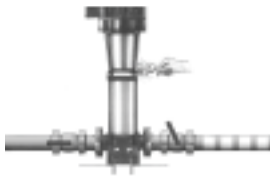
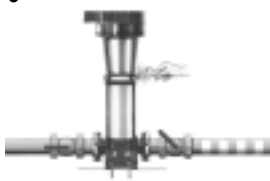

Pay attention to the direction of the vent hole and take care to ensure that the escaping water does not cause injury to persons or damage to the motor or other components.

In hot-water installations, special attention should be paid to the risk of injury caused by scalding hot water.

Step	Action
1	 <p>TM01 1403 4497</p> <p>Close the isolating valve on the discharge side of the pump and open the isolating valve on the suction side.</p>
2	 <p>TM01 1404 4497</p> <p>Remove the priming plug from the pump head and slowly fill the pump with liquid. Replace the priming plug and tighten securely.</p>
3	 <p>TM01 1405 4497</p> <p>See the correct direction of rotation of the pump on the motor fan cover.</p>
4	 <p>TM01 1406 4497</p> <p>Start the pump and check the direction of rotation.</p>
5	 <p>TM01 1407 4497</p> <p>Vent the pump by means of the vent valve in the pump head. At the same time, open the discharge isolating valve a little.</p>
6	 <p>TM01 1408 4497</p> <p>Continue to vent the pump. At the same time, open the discharge isolating valve a little more.</p>
7	 <p>TM01 1409 4497</p> <p>Close the vent valve when a steady stream of liquid runs out of it. Completely open the discharge isolating valve.</p>

CR 2 and 4, CRN 2, 4, 8 and 16:

For these pumps, it is advisable to open the bypass valve during start-up. The bypass valve connects the suction and discharge sides of the pump, thus making the filling procedure easier. When the operation is stable, the bypass valve can be closed. When pumping liquids containing air, it is advisable to leave the bypass valve open.

Fig. 7

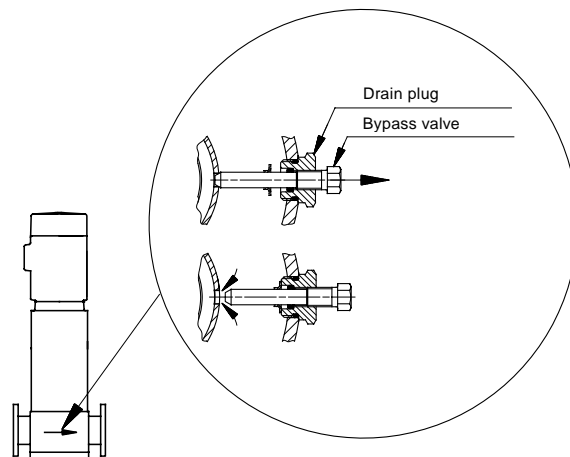

TM01 1243 4097

9. Maintenance



Before starting work on the pump, make sure that all power supplies to the pump have been switched off and that they cannot be accidentally switched on.

Pump bearings and shaft seal are maintenance-free.

If the pump is to be drained for a long period of inactivity, remove one of the coupling guards to inject a few drops of silicone oil on the shaft between the pump head and the coupling. This will prevent the shaft seal faces from sticking.

Motor bearings:

Motors which are not fitted with grease nipples are maintenance-free.

Motors fitted with grease nipples should be lubricated with a high-temperature lithium-based grease, see the instructions on the fan cover.

In the case of seasonal operation (motor is idle for more than 6 months of the year), it is recommended to grease the motor when the pump is taken out of operation.

10. Frost protection

Pumps which are not being used during periods of frost should be drained to avoid damage.

Drain the pump by loosening the vent screw in the pump head and by removing the drain plug from the base.

Care must be taken to ensure that the escaping water does not cause injury to persons or damage to the motor or other components.



In hot-water installations, special attention should be paid to the risk of injury caused by scalding hot water.

Do not tighten the vent screw and replace the drain plug until the pump is to be used again.

CR 2 and 4, CRN 2, 4, 8 and 16:

Before replacing the drain plug in the base, screw the bypass valve out against the stop, see fig. 7.

Fit the drain plug by tightening the large union nut followed by the bypass valve.

11. Service

Note: If a pump has been used for a liquid which is injurious to health or toxic, the pump will be classified as contaminated.

If GRUNDFOS is requested to service the pump, GRUNDFOS must be contacted with details about the pumped liquid, etc. *before* the pump is returned for service. Otherwise GRUNDFOS can refuse to accept the pump for service.

Possible costs of returning the pump are paid by the customer.

However, any application for service (no matter to whom it may be made) must include details about the pumped liquid if the pump has been used for liquids which are injurious to health or toxic.

12. Fault finding chart



Before removing the terminal box cover and before any removal/dismantling of the pump, make sure that the electricity supply has been switched off and that it cannot be accidentally switched on.

Fault	Cause	Remedy
1. Motor does not run when started.	a) Supply failure.	Connect the electricity supply.
	b) Fuses are blown.	Replace fuses.
	c) Motor starter overload has tripped out.	Reactivate the motor protection.
	d) Main contacts in motor starter are not making contact or the coil is faulty.	Replace contacts or magnetic coil.
	e) Control circuit is defective.	Repair the control circuit.
	f) Motor is defective.	Replace the motor.
2. Motor starter overload trips out immediately when supply is switched on.	a) One fuse/automatic circuit breaker is blown.	Cut in the fuse.
	b) Contacts in motor starter overload are faulty.	Replace motor starter contacts.
	c) Cable connection is loose or faulty.	Fasten or replace the cable connection.
	d) Motor winding is defective.	Replace the motor.
	e) Pump mechanically blocked.	Remove the mechanical blocking of the pump.
	f) Overload setting is too low.	Set the motor starter correctly.
3. Motor starter overload trips out occasionally.	a) Overload setting is too low.	Set the motor starter correctly.
	b) Low voltage at peak times.	Check the electricity supply.
4. Motor starter has not tripped out but the pump does not run.	a) Check 1 a), b), d) and e).	
5. Pump capacity not constant.	a) Pump inlet pressure is too low (cavitation).	Check the suction conditions.
	b) Suction pipe/pump partly blocked by impurities.	Clean the pump or suction pipe.
	c) Pump draws in air.	Check the suction conditions.
6. Pump runs but gives no water.	a) Suction pipe/pump blocked by impurities.	Clean the pump or suction pipe.
	b) Foot or non-return valve blocked in closed position.	Repair the foot or non-return valve.
	c) Leakage in suction pipe.	Repair the suction pipe.
	d) Air in suction pipe or pump.	Check the suction conditions.
	e) Motor rotates in the wrong direction.	Change the direction of rotation of the motor.
7. Pump runs backwards when switched off.	a) Leakage in suction pipe.	Repair the suction pipe.
	b) Foot or non-return valve is defective.	Repair the foot or non-return valve.
8. Leakage in shaft seal.	a) Shaft seal is defective.	Replace the shaft seal.
9. Noise.	a) Cavitation occurs in the pump.	Check the suction conditions.
	b) Pump does not rotate freely (frictional resistance) because of incorrect pump shaft position.	Adjust the pump shaft.
	c) Frequency converter operation.	See section 7.1 <i>Frequency converter operation</i> .

13. Disposal

Disposal of this product or parts of it must be carried out according to the following guidelines:

1. Use the local public or private waste collection service.
2. In case such waste collection service does not exist or cannot handle the materials used in the product, please deliver the product or any hazardous materials from it to your nearest GRUNDFOS company or service workshop.

Subject to alterations.

INHALTSVERZEICHNIS

	Seite
1. Sicherheitshinweise	9
1.1 Allgemeines	9
1.2 Kennzeichnung von Hinweisen	9
1.3 Personalqualifikation und -schulung	9
1.4 Gefahren bei Nichtbeachtung der Sicherheitshinweise	9
1.5 Sicherheitsbewußtes Arbeiten	9
1.6 Sicherheitshinweise für den Betreiber/Bediener	9
1.7 Sicherheitshinweise für Wartungs-, Inspektions- und Montagearbeiten	9
1.8 Eigenmächtiger Umbau und Ersatzteilherstellung	9
1.9 Unzulässige Betriebsweisen	9
2. Transport	10
3. Typenbezeichnung	10
3.1 Typenschlüssel für CR, CRN 2, 4, 8 und 16	10
4. Verwendungszweck	10
5. Technische Daten	10
5.1 Umgebungstemperatur	10
5.2 Medientemperatur	10
5.3 Maximal zulässiger Betriebsdruck und Medientemperatur für die Wellenabdichtung	10
5.4 Min. Zulaufdruck	10
5.5 Max. Zulaufdruck	11
5.6 Elektrische Daten	11
5.7 Schalldämmigkeit	11
5.8 Maße und Gewichte	11
5.9 Schallpegel	11
6. Montage	11
7. Justierung der Kupplung	11
8. Elektrischer Anschluß	12
8.1 Frequenzrichterbetrieb	12
9. Inbetriebnahme	12
10. Wartung	13
11. Frostsicherung	13
12. Service	13
12.1 Verunreinigte Pumpen	13
12.2 Ersatzteile/Zubehör	13
13. Störungsübersicht	14
14. Entsorgung	14

1. Sicherheitshinweise

1.1 Allgemeines

Diese Montage- und Betriebsanleitung enthält grundlegende Hinweise, die bei Aufstellung, Betrieb und Wartung zu beachten sind. Sie ist daher unbedingt vor Montage und Inbetriebnahme vom Monteur sowie dem zuständigen Fachpersonal/Betreiber zu lesen. Sie muß ständig am Einsatzort der Anlage verfügbar sein.

Es sind nicht nur die unter diesem Abschnitt "Sicherheitshinweise" aufgeführten, allgemeinen Sicherheitshinweise zu beachten, sondern auch die unter den anderen Abschnitten eingefügten, speziellen Sicherheitshinweise.

1.2 Kennzeichnung von Hinweisen



Die in dieser Montage- und Betriebsanleitung enthaltenen Sicherheitshinweise, die bei Nichtbeachtung Gefährdungen für Personen hervorrufen können, sind mit allgemeinem Gefahrensymbol "Sicherheitszeichen nach DIN 4844-W9" besonders gekennzeichnet.

Achtung

Dieses Symbol finden Sie bei Sicherheitshinweisen, deren Nichtbeachtung Gefahren für die Maschine und deren Funktionen hervorrufen kann.

Hinweis

Hier stehen Ratschläge oder Hinweise, die das Arbeiten erleichtern und für einen sicheren Betrieb sorgen.

Direkt an der Anlage angebrachte Hinweise wie z.B.

- Drehrichtungspfeil
 - Kennzeichnung für Fluidanschlüsse
- müssen unbedingt beachtet und in vollständig lesbarem Zustand gehalten werden.

1.3 Personalqualifikation und -schulung

Das Personal für Bedienung, Wartung, Inspektion und Montage muß die entsprechende Qualifikation für diese Arbeiten aufweisen. Verantwortungsbereich, Zuständigkeit und die Überwachung des Personals müssen durch den Betreiber genau geregelt sein.

1.4 Gefahren bei Nichtbeachtung der Sicherheitshinweise

Die Nichtbeachtung der Sicherheitshinweise kann sowohl eine Gefährdung für Personen als auch für die Umwelt und Anlage zur Folge haben. Die Nichtbeachtung der Sicherheitshinweise kann zum Verlust jeglicher Schadenersatzansprüche führen.

Im einzelnen kann Nichtbeachtung beispielsweise folgende Gefährdungen nach sich ziehen:

- Versagen wichtiger Funktionen der Anlage
- Versagen vorgeschriebener Methoden zur Wartung und Instandhaltung
- Gefährdung von Personen durch elektrische und mechanische Einwirkungen

1.5 Sicherheitsbewußtes Arbeiten

Die in dieser Montage- und Betriebsanleitung aufgeführten Sicherheitshinweise, die bestehenden nationalen Vorschriften zur Unfallverhütung sowie eventuelle interne Arbeits-, Betriebs- und Sicherheitsvorschriften des Betreibers, sind zu beachten.

1.6 Sicherheitshinweise für den Betreiber/Bediener

- Ein vorhandener Berührungsschutz für sich bewegende Teile darf bei sich in Betrieb befindlicher Anlage nicht entfernt werden.
- Gefährdungen durch elektrische Energie sind auszuschließen (Einzelheiten hierzu siehe z.B. in den Vorschriften des VDE und der örtlichen Energieversorgungsunternehmen).

1.7 Sicherheitshinweise für Wartungs-, Inspektions- und Montagearbeiten

Der Betreiber hat dafür zu sorgen, daß alle Wartungs-, Inspektions- und Montagearbeiten von autorisiertem und qualifiziertem Fachpersonal ausgeführt werden, das sich durch eingehendes Studium der Montage- und Betriebsanleitung ausreichend informiert hat.

Grundsätzlich sind Arbeiten an der Anlage nur im Stillstand durchzuführen. Die in der Montage- und Betriebsanleitung beschriebene Vorgehensweise zum Stillsetzen der Anlage muß unbedingt eingehalten werden.

Unmittelbar nach Abschluß der Arbeiten müssen alle Sicherheits- und Schutzeinrichtungen wieder angebracht bzw. in Funktion gesetzt werden.

Vor der Wiederinbetriebnahme sind die im Abschnitt 9. *Inbetriebnahme* aufgeführten Punkte zu beachten.

1.8 Eigenmächtiger Umbau und Ersatzteilherstellung

Umbau oder Veränderungen der Anlage sind nur nach Absprache mit dem Hersteller zulässig. Originalersatzteile und vom Hersteller autorisiertes Zubehör dienen der Sicherheit. Die Verwendung anderer Teile kann die Haftung für die daraus entstehenden Folgen aufheben.

1.9 Unzulässige Betriebsweisen

Die Betriebssicherheit der gelieferten Anlage ist nur bei bestimmungsgemäßer Verwendung entsprechend Abschnitt 4. *Verwendungszweck* der Montage- und Betriebsanleitung gewährleistet. Die in den technischen Daten angegebenen Grenzwerte dürfen auf keinen Fall überschritten werden.



Fig. A

- Ⓒ **Maximum permissible operating pressure:**
- Ⓓ **Max. zulässiger Betriebsdruck:**
- Ⓕ **Pression de fonctionnement maxi autorisée:**
- Ⓘ **Massima pressione di esercizio possibile:**
- Ⓔ **Presión máxima de funcionamiento permitida:**
- ⒫ **Pressão máxima de funcionamento permissível:**
- Ⓖ **Μέγιστη επιτρεπτή πίεση λειτουργίας:**
- Ⓖ **Maximaal toelaatbare werkdruk:**
- Ⓒ **Max. tillåtet driftstryck:**
- Ⓕ **Suurin sallittu käyttöpain:**
- Ⓓ **Maks. tilladeligt driftstryk:**

Frequency Frequenz Fréquence Frequenza Frecuencia Frequência Συχνότητα Frequentie Frekvens Taajuus Frekvens	Pump type Pumptyp Type de pompe Pompa tipo Tipo de bomba Modelo da bomba Τύπος αντλίας Pomptyp Pumptyp Pumpputyyppi Pumpetype	Curve Kurve Courbe Curva Curva Καμπύλη Curve Kurva Käyrä Kurve
50 Hz	CR, CRN 2-20 → CR, CRN 2-150	1
	CR, CRN 2-180 → CR, CRN 2-260	2
	CR, CRN 4-20/1 → CR, CRN 4-160	1
	CR, CRN 4-190 → CR, CRN 4-220	2
	CR, CRN 8-20/1 → CR, CRN 8-120	1
	CR, CRN 8-140 → CR, CRN 8-200	3
60 Hz	CR, CRN 16-30/2 → CR, CRN 16-80	1
	CR, CRN 16-100 → CR, CRN 16-160	3
	CR, CRN 2-20 → CR, CRN 2-150	1
	CR, CRN 2-180 → CR, CRN 2-260	2
	CR, CRN 4-20/1 → CR, CRN 4-160	1
	CR, CRN 4-190 → CR, CRN 4-220	2
60 Hz	CR, CRN 8-20/1 → CR, CRN 8-120	1
	CR, CRN 8-140 → CR, CRN 8-200	3
	CR, CRN 16-30/2 → CR, CRN 16-80	1
	CR, CRN 16-100 → CR, CRN 16-160	3

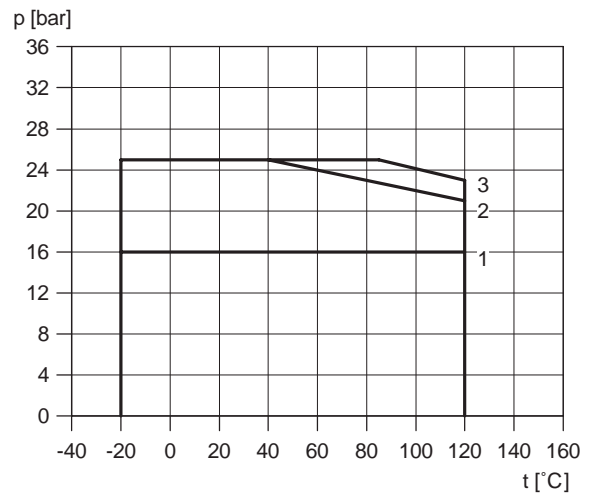

TM02 7530 3703

Fig. B

- Ⓒ **GB** Maximum inlet pressure for CR and CRN:
- Ⓒ **D** Max. Zulaufdruck für CR und CRN:
- Ⓒ **F** Pression maximum d'entrée pour CR et CRN:
- Ⓒ **I** Massima pressione in aspirazione per CR e CRN:
- Ⓒ **E** Presión máxima de entrada para CR y CRN:
- Ⓒ **P** Pressão máxima de admissão CR e CRN:
- Ⓒ **GR** Μέγιστη πίεση εισόδου για CR και CRN:
- Ⓒ **NL** Maximale inlaatdruk m.b.t. type CR en CRN:
- Ⓒ **S** Max. tilloppstryck för CR och CRN:
- Ⓒ **SF** Suurin tulopaine CR ja CRN:
- Ⓒ **DK** Maks. tilløbstryk for CR og CRN:

50 Hz		60 Hz	
CR, CRN 2			
CR, CRN 2-20	6 bar	CR, CRN 2-20 → CR, CRN 2-60	10 bar
CR, CRN 2-30 → CR, CRN 2-110	10 bar	CR, CRN 2 -70 → 2-180	15 bar
CR, CRN 2-130 → CR, CRN 2-260	15 bar		
CR, CRN 4			
CR, CRN 4-20/1 → CR, CRN 4-20	6 bar	CR, CRN 4-20/1 → CR, CRN 4-20	6 bar
CR, CRN 4-30 → CR, CRN 4-100	10 bar	CR, CRN 4-30 → CR, CRN 4-80/7	10 bar
CR, CRN 4-120 → CR, CRN 4-220	15 bar	CR, CRN 4-80 → CR, CRN 4-160	15 bar
CR, CRN 8			
CR, CRN 8-20/1 → CR, CRN 8-60	6 bar	CR, CRN 8-20/1 → CR, CRN 8-40	6 bar
CR, CRN 8-80 → CR, CRN 8-200	10 bar	CR, CRN 8-50 → CR, CRN 8-140	10 bar
CR, CRN 16			
CR, CRN 16-30/2 → CR, CRN 16-30	6 bar	CR, CRN 16-30/2 → CR, CRN 16-30	6 bar
CR, CRN 16-40 → CR, CRN 16-160	10 bar	CR, CRN 16-40 → CR, CRN 16-100	10 bar

Fig. C

Pump Type	PN 16			PJE			CLAMP			UNION			DIN			L ₁ [mm]	L ₂ [mm]	B ₁ [mm]	B ₂ [mm]	ø [mm]
	L [mm]	H [mm]	D [Rp]	L [mm]	H [mm]	D [mm]	L [mm]	H [mm]	D [mm]	L [mm]	H [mm]	D [G]	L [mm]	H [mm]	DN					
CR 2	160	50	1										250	75	25	100	147	180	210	13
CRN 2				210	50	42,4	162	50	32	210	50	2	250	75	25	100	150	180	210	13
CR 4	160	50	1¼										250	75	32	100	147	180	210	13
CRN 4				210	50	42,4	162	50	32	210	50	2	250	75	32	100	150	180	210	13
CR 8	200	80	1½										280	80	40	130	190	215	246	13
CRN 8				261	80	60,3	202	80	51	261	80	2¾	280	80	40	130	199	215	247	14
CR 16													300	90	50	130	190	215	246	13
CRN 16				261	80	60,3	202	90	51	261	90	2¾	300	90	50	130	199	215	247	14

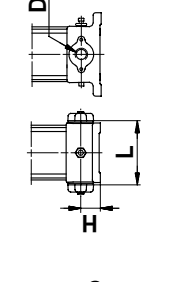
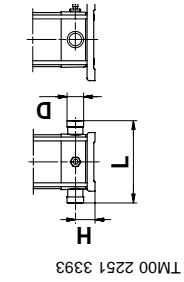
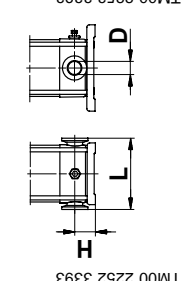
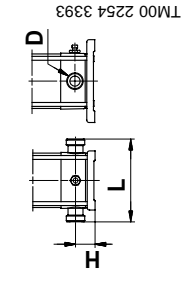
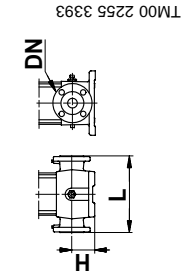
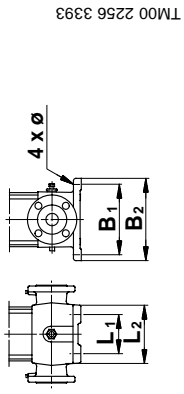
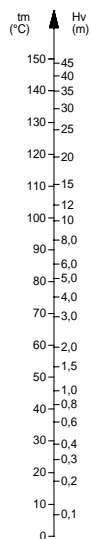

Fig. D

- Ⓒ **GB** Airborne noise emitted by pumps with motors fitted by GRUNDFOS:
- Ⓒ **D** Luftschallemission von Pumpen mit Motoren, die von GRUNDFOS montiert sind:
- Ⓒ **F** Bruit aérien émis par les pompes avec moteurs montés par GRUNDFOS:
- Ⓒ **I** Rumore aereo emesso da pompe dotate di motori installati da GRUNDFOS:
- Ⓒ **E** Nivel de ruido producido por bombas con motores montados por GRUNDFOS:
- Ⓒ **P** Ruído emitido pelas electrobombas montadas pela GRUNDFOS:
- Ⓒ **GR** Θόρυβος που εκπέμπεται στον αέρα από αντλίες εφοδιασμένες με κινητήρες από τη GRUNDFOS:
- Ⓒ **NL** Geluidsdruk van pompen met een door GRUNDFOS gemonteerde motor:
- Ⓒ **S** Ljudtrycksnivå från pumpar med motorer monterade av GRUNDFOS:
- Ⓒ **SF** Ilmassa kantautuva ääni GRUNDFOS'in asentamalla moottoreilla:
- Ⓒ **DK** Luftbåren støj fra pumper med motorer monteret af GRUNDFOS:

Motor [kW]	50 Hz	60 Hz
	\bar{L}_{pA} [dB(A)]	\bar{L}_{pA} [dB(A)]
0.25	<70	<70
0.37	<70	<70
0.55	<70	<70
0.75	<70	<70
1.1	<70	<70
1.5	<70	<70
2.2	<70	<70
3.0	<70	<70
4.0	<70	<70
5.5	<70	<70
7.5	<70	72
11	80	84
15	72	77

Fig. E



TMO0 3037 3493

CR, CRN 2 and 4

Fig. F

A

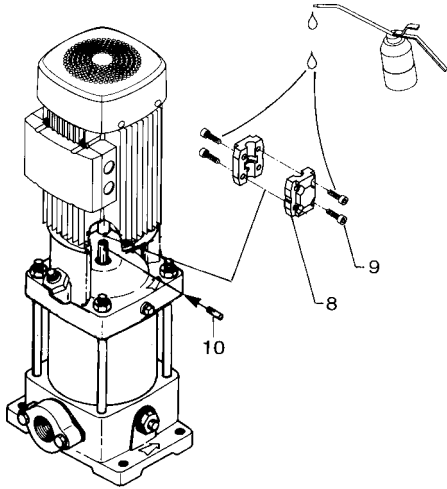

TM01 2642 2198

B

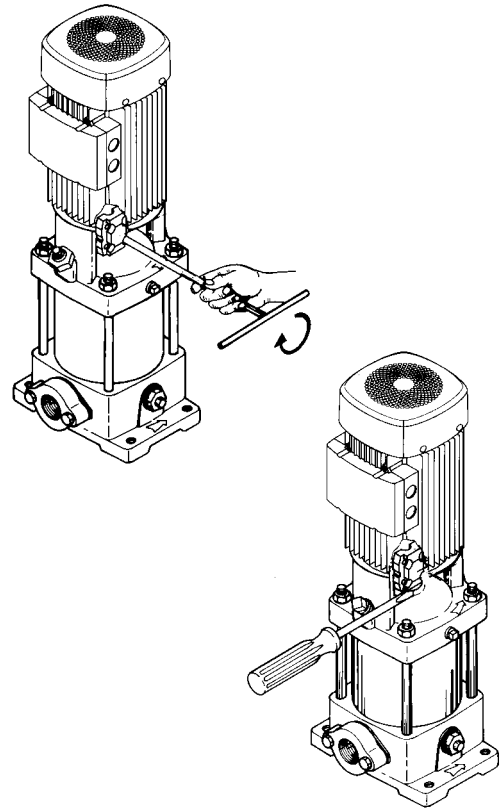

TM01 2643 2198

C

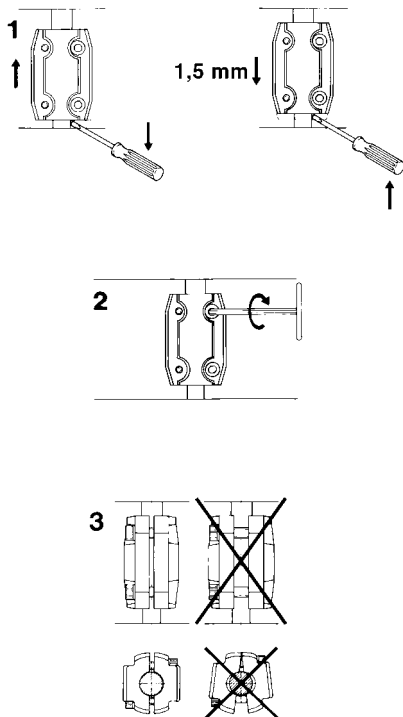

TM01 2648 2198

D

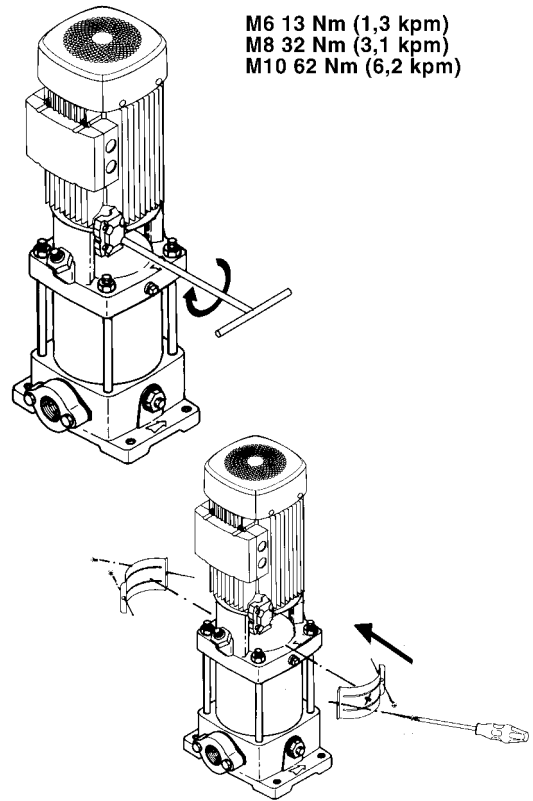

TM01 2644 2198

CR, CRN 8 and 16

Fig. G

A

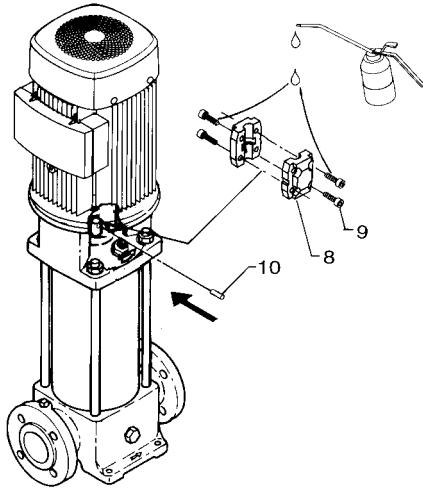

TM01 2645 2198

B

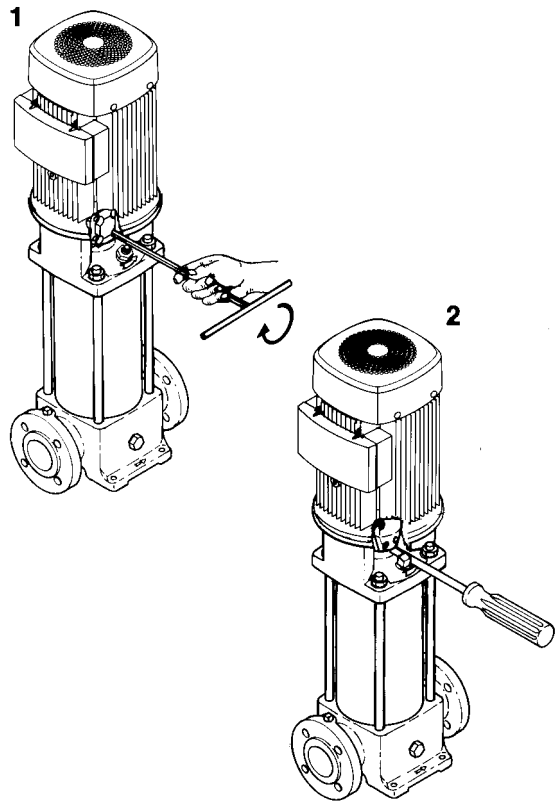

TM01 2646 2198

C

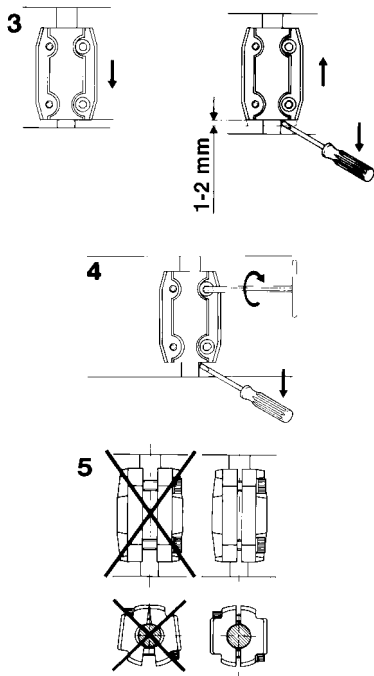

TM01 2649 2198

D

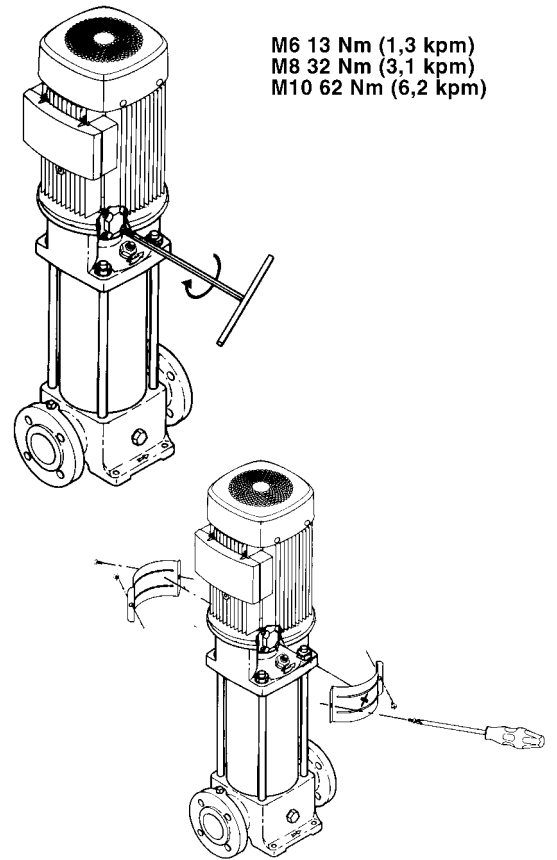

TM01 2647 2198

NPSH

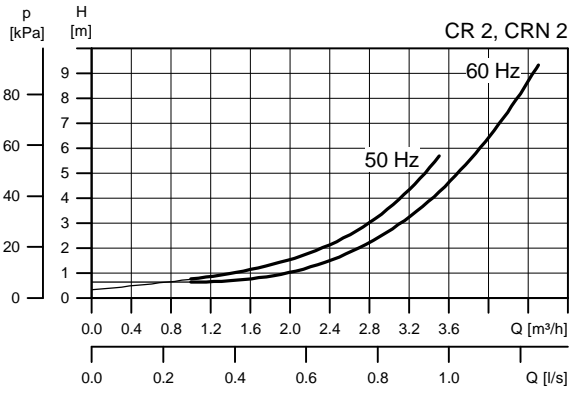

TM00 1625 4597

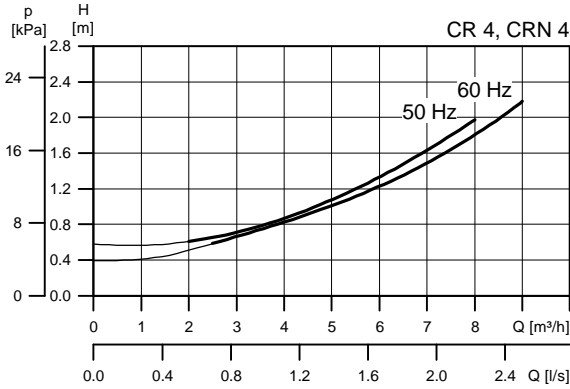

TM00 1626 4597

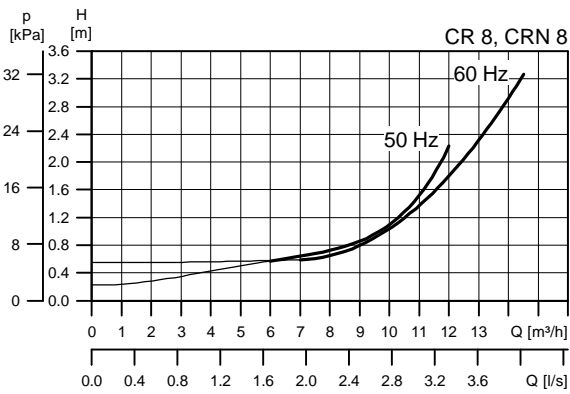

TM00 1627 4597

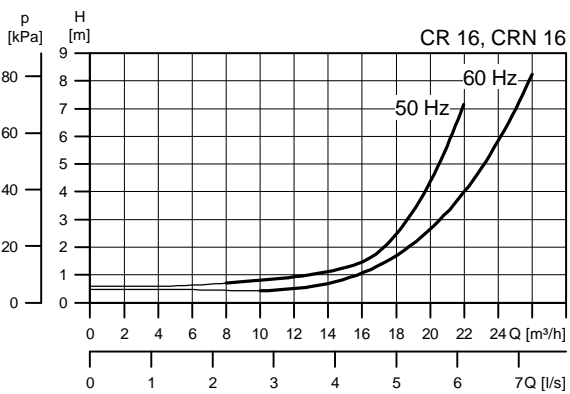

TM00 1628 4597

Denmark

GRUNDFOS DK A/S
Poul Due Jensens Vej 7A
DK-8850 Bjerringbro
Tlf.: +45-87 50 50 50
Telefax: +45-87 50 51 51

Argentina

Bombas GRUNDFOS de Argentina S.A.
Ruta Panamericana km. 37.500 Lote 34A
1619 - Garin
Pcia. de Buenos Aires
Phone: +54-3327 414 444
Telefax: +54-3327 411 111

Australia

GRUNDFOS Pumps Pty. Ltd.
P.O. Box 2040
Regency Park
South Australia 5942
Phone: +61-8-8461-4611
Telefax: +61-8-8340 0155

Austria

GRUNDFOS Pumpen Vertrieb Ges.m.b.H.
Grundfosstraße 2
A-5082 Grödig/Salzburg
Tel.: +43-6246-883-0
Telefax: +43-6246-883-30

Belgium

N.V. GRUNDFOS Bellux S.A.
Boomsesteenweg 81-83
B-2630 Aartselaar
Tél.: +32-3-870 7300
Télécopie: +32-3-870 7301

Brazil

GRUNDFOS do Brasil Ltda.
Rua Tomazina 106
CEP 83325 - 040
Pinhais - PR
Phone: +55-41 668 3555
Telefax: +55-41 668 3554

Canada

GRUNDFOS Canada Inc.
2941 Brighton Road
Oakville, Ontario
L6H 6C9
Phone: +1-905 829 9533
Telefax: +1-905 829 9512

China

GRUNDFOS Pumps (Shanghai) Co. Ltd.
22 Floor, Xin Hua Lian Building
755-775 Huai Hai Rd, (M)
Shanghai 200020
PRC
Phone: +86-512-67 61 11 80
Telefax: +86-512-67 61 81 67

Czech Republic

GRUNDFOS s.r.o.
Cajkovského 21
779 00 Olomouc
Phone: +420-585-716 111
Telefax: +420-585-438 906

Finland

OY GRUNDFOS Pumput AB
Mestarintie 11
Piispankylä
FIN-01730 Vantaa (Helsinki)
Phone: +358-9 878 9150
Telefax: +358-9 878 91550

France

Pompes GRUNDFOS Distribution S.A.
Parc d'Activités de Chesnes
57, rue de Malacombe
F-38290 St. Quentin Fallavier (Lyon)
Tél.: +33-4 74 82 15 15
Télécopie: +33-4 74 94 10 51

Germany

GRUNDFOS GMBH
Schlüterstr. 33
40699 Erkrath
Tel.: +49-(0) 211 929 69-0
Telefax: +49-(0) 211 929 69-3799
e-mail: infoservice@grundfos.de
Service in Deutschland:
e-mail: kundendienst@grundfos.de

Greece

GRUNDFOS Hellas A.E.B.E.
20th km. Athinon-Markopoulou Av.
P.O. Box 71
GR-19002 Peania
Phone: +0030-210-66 83 400
Telefax: +0030-210-66 46 273

Hong Kong

GRUNDFOS Pumps (Hong Kong) Ltd.
Unit 1, Ground floor
Siu Wai Industrial Centre
29-33 Wing Hong Street &
68 King Lam Street, Cheung Sha Wan
Kowloon
Phone: +852-27861706/27861741
Telefax: +852-27858664

Hungary

GRUNDFOS Hungária Kft.
Park u. 8
H-2045 Törökbalint,
Phone: +36-34 520 100
Telefax: +36-34 520 200

India

GRUNDFOS Pumps India Private Limited
Flat A, Ground Floor
61/62 Chamiers Aptmt
Chamiers Road
Chennai 600 028
Phone: +91-44 432 3487
Telefax: +91-44 432 3489

Indonesia

PT GRUNDFOS Pompa
Jl. Rawa Sumur III, Blok III / CC-1
Kawasan Industri, Pulogadung
Jakarta 13930
Phone: +62-21-460 6909
Telefax: +62-21-460 6910/460 6901

Ireland

GRUNDFOS (Ireland) Ltd.
Unit 34, Stillorgan Industrial Park
Blackrock
County Dublin
Phone: +353-1-2954926
Telefax: +353-1-2954739

Italy

GRUNDFOS Pompe Italia S.r.l.
Via Gran Sasso 4
I-20060 Truccazzano (Milano)
Tel.: +39-02-95838112
Telefax: +39-02-95309290/95838461

Japan

GRUNDFOS Pumps K.K.
1-2-3, Shin Miyakoda
Hamamatsu City
Shizuoka pref. 431-21
Phone: +81-53-428 4760
Telefax: +81-53-484 1014

Korea

GRUNDFOS Pumps Korea Ltd.
6th Floor, Aju Building 679-5
Yeoksam-dong, Kangnam-ku, 135-916
Seoul Korea
Phone: +82-2-5317 600
Telefax: +82-2-5633 725

Malaysia

GRUNDFOS Pumps Sdn. Bhd.
7 Jalan Peguam U1/25
Glenmarie Industrial Park
40150 Shah Alam
Selangor
Phone: +60-3-5569 2922
Telefax: +60-3-5569 2866

Mexico

Bombas GRUNDFOS de Mexico S.A. de C.V.
Boulevard TLC No. 15
Parque Industrial Stiva Aeropuerto
Apodaca, N.L. 66600
Mexico
Phone: +52-81-8144 4000
Telefax: +52-81-8144 4010

Netherlands

GRUNDFOS Nederland B.V.
Postbus 104
NL-1380 AC Weesp
Tel.: +31-294-492 211
Telefax: +31-294-492244/492299

New Zealand

GRUNDFOS Pumps NZ Ltd.
17 Beatrice Tinsley Crescent
North Harbour Industrial Estate
Albany, Auckland
Phone: +64-9-415 3240
Telefax: +64-9-415 3250

Norway

GRUNDFOS Pumper A/S
Strømsveien 344
Postboks 235, Leirdal
N-1011 Oslo
Tlf.: +47-22 90 47 00
Telefax: +47-22 32 21 50

Poland

GRUNDFOS Pompy Sp. z o.o.
ul. Klonowa 23
Baranowo k. Poznania
PL-62-081 Przemierowo
Phone: +48-61-650 13 00
Telefax: +48-61-650 13 50

Portugal

Bombas GRUNDFOS Portugal, S.A.
Rua Calvet de Magalhães, 241
Apartado 1079
P-2770-153 Paço de Arcos
Tel.: +351-21-440 76 00
Telefax: +351-21-440 76 90

Russia

OOO GRUNDFOS
Shkolnaya 39
RUS-109544 Moscow
Phone: +7-095 564 88 00, +7-095 737 30 00
Telefax: +7-095 564 88 11, +7-095 737 75 36
e-mail: grundfos.moscow@grundfos.com

Singapore

GRUNDFOS (Singapore) Pte. Ltd.
24 Tuas West Road
Jurong Town
Singapore 638381
Phone: +65-6865 1222
Telefax: +65-6861 8402

Spain

Bombas GRUNDFOS España S.A.
Camino de la Fuentesilla, s/n
E-28110 Algete (Madrid)
Tel.: +34-91-848 8800
Telefax: +34-91-628 0465

Sweden

GRUNDFOS AB
Box 63, Angeredsvinkeln 9
S-424 22 Angered
Tel.: +46-771-32 23 00
Telefax: +46-31 331 94 60

Switzerland

GRUNDFOS Pumpen AG
Bruggacherstrasse 10
CH-8117 Fällanden/ZH
Tel.: +41-1-806 8111
Telefax: +41-1-806 8115

Taiwan

GRUNDFOS Pumps (Taiwan) Ltd.
14, Min-Yu Road
Tunglo Industrial Park
Tunglo, Miao-Li County
Taiwan, R.O.C.
Phone: +886-37-98 05 57
Telefax: +886-37-98 05 70

Thailand

GRUNDFOS (Thailand) Ltd.
947/168 Moo 12, Bangna-Trad Rd., K.M. 3,
Bangna, Phrakonong
Bangkok 10260
Phone: +66-2-744 1785 ... 91
Telefax: +66-2-744 1775 ... 6

Turkey

GRUNDFOS POMPA SAN. ve TIC. LTD. STI
Bulgurlu Caddesi no. 32
TR-81190 Üsküdar Istanbul
Phone: +90 - 216-4280 306
Telefax: +90 - 216-3279 988

United Arab Emirates

GRUNDFOS Gulf Distribution
P.O. Box 16768
Jebel Ali Free Zone
Dubai
Phone: +971-4- 8815 166
Telefax: +971-4-8815 136

United Kingdom

GRUNDFOS Pumps Ltd.
Grovebury Road
Leighton Buzzard/Beds. LU7 8TL
Phone: +44-1525-850000
Telefax: +44-1525-850011

U.S.A.

GRUNDFOS Pumps Corporation
17100 West 118th Terrace
Olathe, Kansas 66061
Phone: +1-913-227-3400
Telefax: +1-913-227-3500

96 42 36 35 0903	30
Repl. V7 14 13 54 0500	