

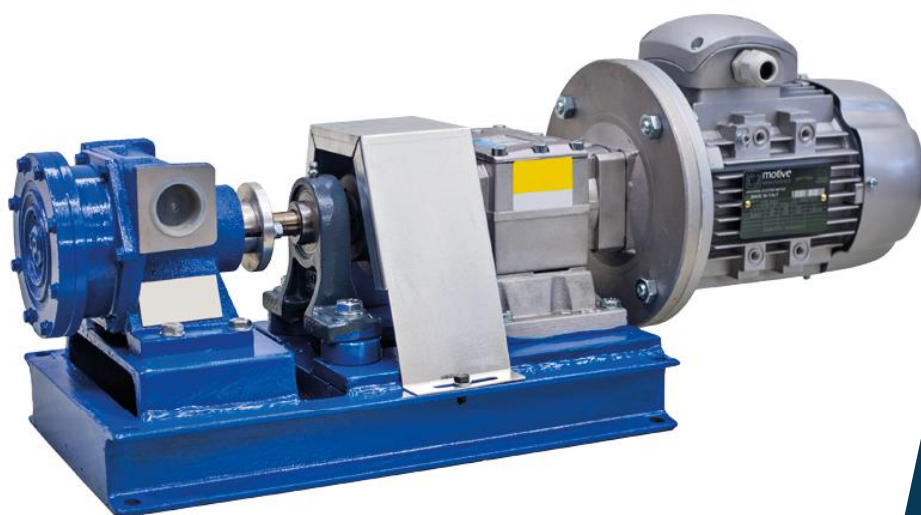

/ Pompe 3P®
Hollow Rotary Disk Pumps
Positive Displacement Pumps
Series: M - D - DN-CN-MN - TURBIK

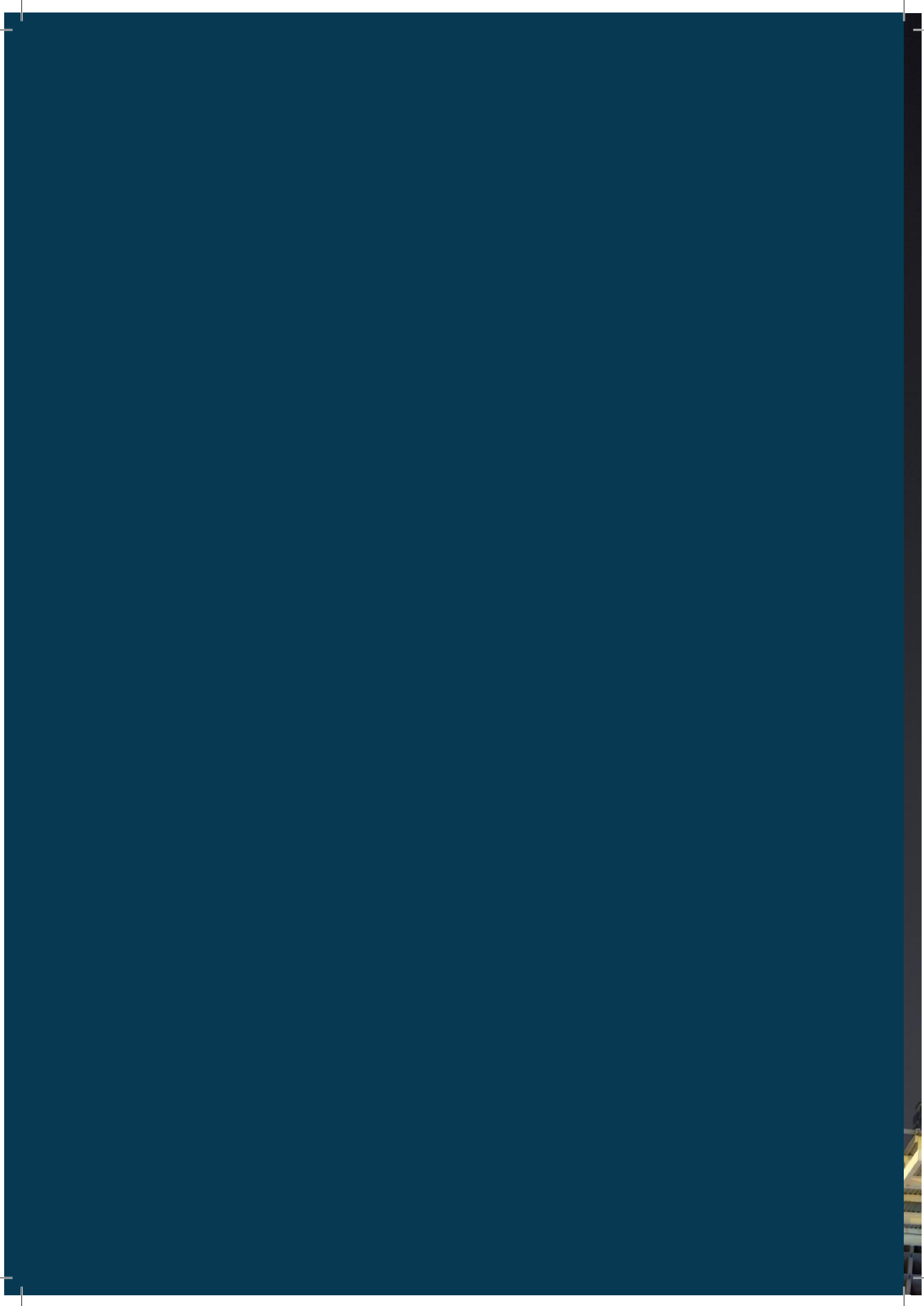





POMPE 3P®

Pompe 3P® is a trademark of 3P Prinz® srl





/ Pompe 3P[®] – Hollow Rotary Disk Pumps Positive Displacement Pumps Series: M – D – DN-CN-MN – TURBIK

The **Pompe 3P[®]** Hollow Rotary Disk Pumps are Rotating Positive Displacement Pumps. Their trim consists mainly of one Hollow Rotating Disk that oscillates inside the Pump Casing, pumping the fluid from the inlet to the outlet port.

The **Pompe 3P[®]** Hollow Rotary Disk Pumps are Self-Priming, Reversible, capable of Handling Solid Particles, Highly Reliable and Long-Lasting thanks to their Low Rotating Speed.

These **Pompe 3P[®]** Pumps can be supplied with One or Two Hollow Rotary Disks properly phased together.

A Wide Range of Executions, Customizations and Accessories are available.

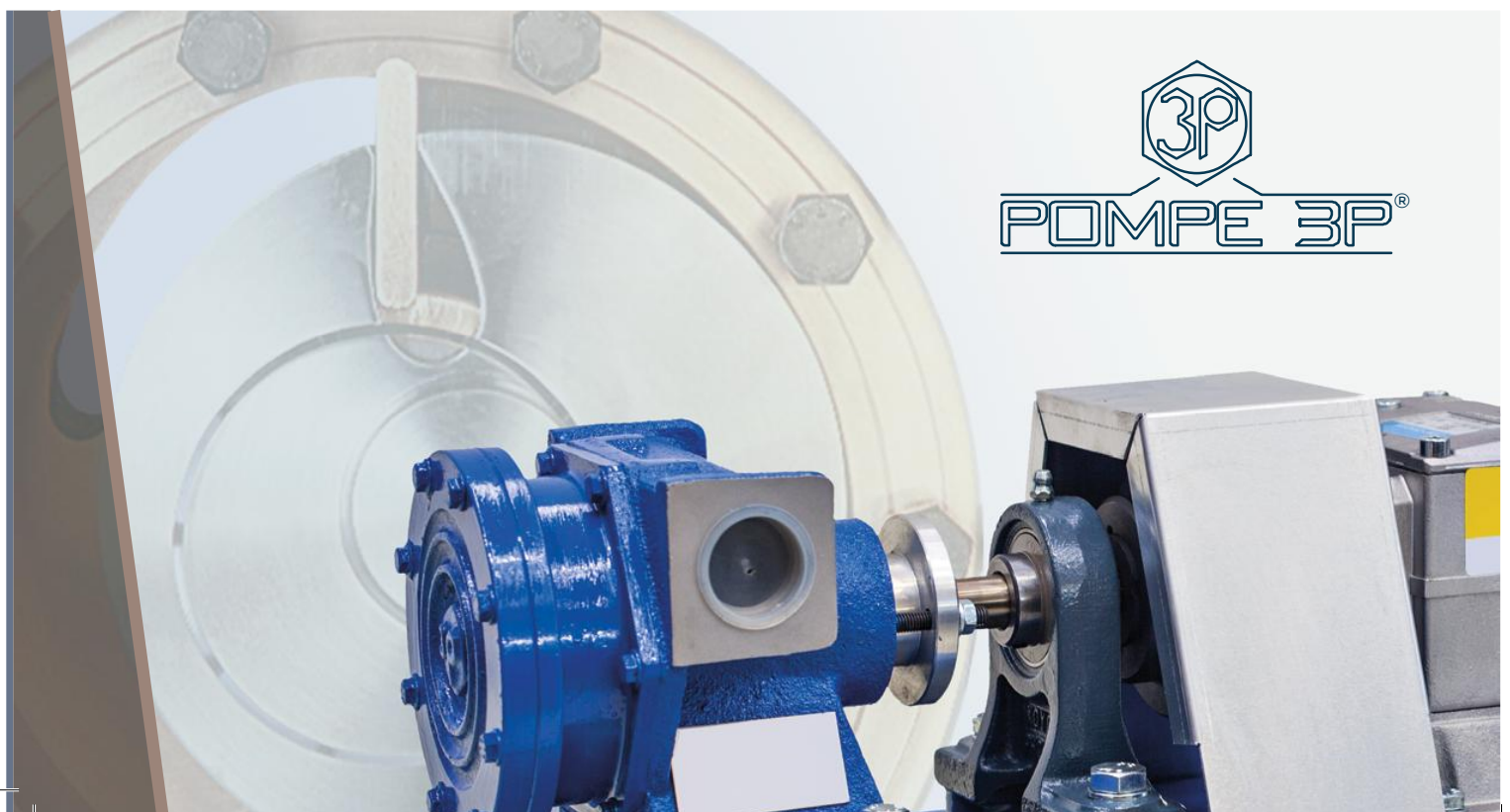

/ EXECUTIONS

- Standard
- API 676

/ ADVANTAGES AND GENERAL FEATURES

- **Self-Priming without any auxiliary devices:** the Hollow Rotary Disk Pumps create an High Suction Lift that allows them to start up without being primed – they just need to be filled with liquid only before the first start-up – they do not generally need a foot valve (unless fluid is very dry, volatile or with low viscosity)
- **Low Operating Speed:** the Hollow Rotary Disk Pumps rotate at Low RPMs, making them particularly suitable to **handle Shear-Sensitive and Highly Viscous Fluids**, minimizing foaming and emulsification of the product – in addition, lower velocity means Less Wear-Out, **High Reliability and Long-Lasting**.
- **Reverse Flow** by operating in reverse rotation while keeping Constant Capacity, same Head and Performances – this feature can be used also for emptying the downstream pipes and is very useful in case of tank loading and offloading: no need to use another pump or switch the ports!
- **Elasticity of the Disk**, with **Self-Recover** of the worn out parts and of the thermal expansions, **allowing the Passage of Solid Particles** in the fluid.
- **High Suction Lift** - about 7–8 meters
- **Low Noise Level and Low Vibrations** thanks to its low speed and smooth operation
- **High Efficiency** – thanks to our long experience in the selection of the materials of the mutually sliding parts, to the long-proven design and thanks to the optimized pumping mechanism
- **Average Flow Rate is Constant** regardless of changes in viscosity
- Capable of handling fluids with a Very Wide Range of Viscosities: from Medium to High and Very High Viscosities - up to 200.000 cSt – this makes the Hollow Rotary Disk Pumps versatile on many applications in the same plants – One Pump can fit Many Fluids
- **Simplicity of the Mechanism:** there are very few moving parts, and Spare Parts Stock is Reduced and Always Readily Available
- **Compact Design and Dimensions, Easy Access for Maintenance;** Access to the internal components for maintenance is simple (just by removing the cover)
- **Entrapped Air or Gas in the Liquid are tolerated in small percentages**
- Capability of **Dry Running** for a limited period and in particular conditions
- **Good Dosing Capability:** on each revolution, the fluid pumped is equivalent to the hollow disk pump cavity volume
- **Flow Rates up to 250 m³/h (1100 GPM)**
- **Standard Pressure Version at 8 bar (116 PSI) - High Pressures Version up to 12 bar (174 PSI) or 20 bar (290 PSI)**
- **Temperatures up to 280°C (536°F)**

Visit site
www.3pprinz.com





HOLLOW ROTARY DISK PUMPS

MANY APPLICATIONS
SAME PERFORMANCE

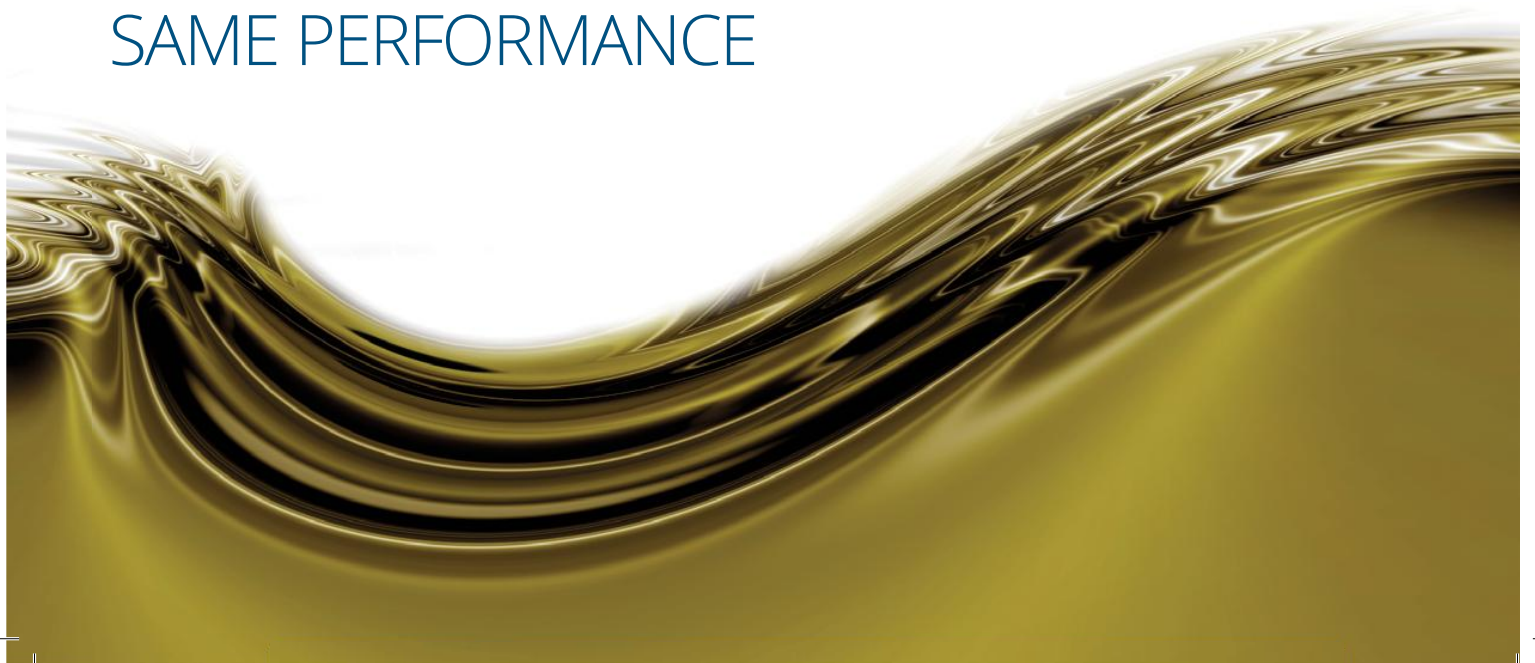

/ ENERGY

3P Prinz pumps are widely used to load, transfer and unload petroleum and its products.

Typical Applications Handled:

- Fuel Oil (Light or Heavy)
- Methanol
- Gasoline
- Ethanol
- Diesel
- Oil & Gas
- Biofuels
- Processing
- Feedstock
- Light & Heavy Hydrocarbons
- Bitumen & Tar

/ PROCESS

Chemical companies around the world rely on 3P Prinz for their fluid transfer needs. 3P Prinz transfers raw products from storage containers to loading of product onto transport vehicles.

Typical Applications Handled:

- Acids
- Paper
- Glue
- Carbon Dioxide
- Paints
- Inks & Coatings
- Solvents
- Isocyanate
- Polyols
- Soap & Detergents
- Polyurethane
- Fibers in Suspension

/ MILITARY & MARINE

3P Prinz supports the military and marine industry with leading-edge hollow rotary disk pumps.

Typical Applications Handled:

- Fuel Oil
- Kerosene
- Gasoline
- Lube Oil
- Bilge Water
- Sludge, Mud, Sewage
- Waste Oil

/ TRANSPORT

3P Prinz pumps move raw product from rail and transport vehicles to bulk storage tanks and facilities.

Typical Applications Handled:

- Oils
- Asphalt
- Fuels
- Liquid Waste
- Chemicals
- Emulsions
- Liquid Fertilizers
- Liquid Foods
- Dry Bulk
- Bio-lube
- Sewage and Sludge

/ HYGIENIC & FOOD

3P Prinz is present in the food, beverage and pharmaceutical industries with its innovative Disc Pumps that improve productivity and efficiency.

Typical Applications Handled:

- Dairy Products
- Beverages
- Confectionery
- Sauces & Dressings
- Animal Food
- Syrups & Molasses
- Vegetable & Animal Oils
- Cosmetics
- Pharmaceutical



/ WORKING PRINCIPLE

The basic operating principle is the following:

The Hollow Rotary Disk, during its oscillating movement, adheres with the internal and circumferential surface of the pump casing, creating a depression in the suction line that causes the fluid to flow into the cavity and that pumps the fluid from the cavity into the supply line.

Looking more in details the Pump components and principle of operation, we can see that the disk is mounted eccentrically to the pump shaft and is guided by the diaphragm: the axis rotation will cause the disk to oscillate and to adhere either with the internal circumferential area of the pump casing either with the eccentric end of the shaft and the diaphragm, thus creating two separate leak-tight chambers.

The volume of the chamber in contact with the inlet line increases constantly, creating the vacuum that allows to suction the fluid into the pump; on the other chamber, the volume is decreasing constantly, causing the fluid to be pumped out to the supply line.

A complete revolution of the shaft equals to the hollow disk pump cavity volume to displaced and the equivalent amount of fluid is pumped out (just minor leaks through the disk contact points, but this loss is stable if viscosity does not change).

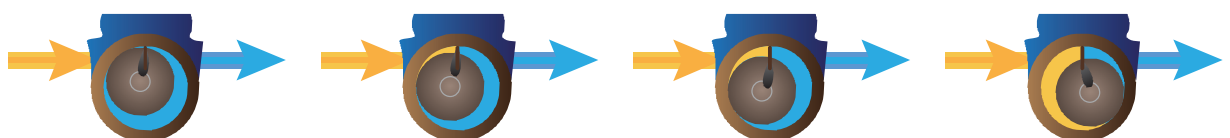
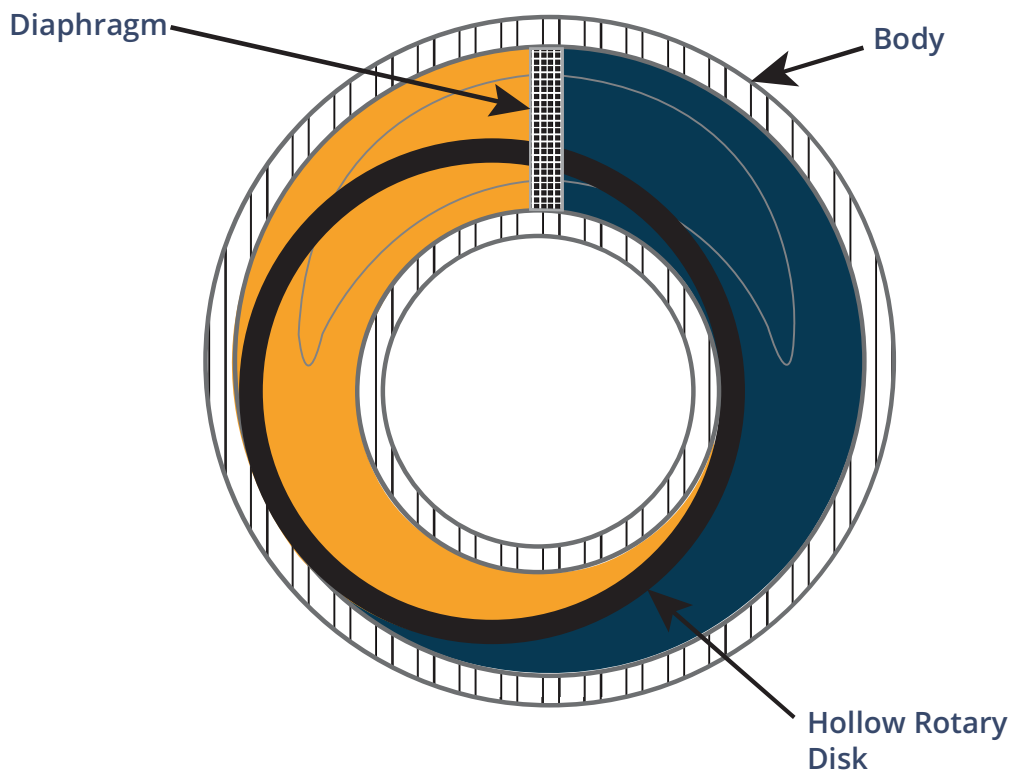

Fluid drawn in Fluid Outgoing

/ PRESSURE BALANCING

The internal forces are Balanced, both Axially and Radially: the sum of the pressures inside and outside the hollow disk is always in a plane perpendicular to the disk's eccentric pin radius and is always tangent to the circumference drawn by the disk center.

There are No Radial Forces that would tend to detach the disk from the pump enclosure and that would create a leak during operation.

In addition, there is No Sliding Friction between disk and pump enclosure.

The overall sum of pressure is constant in whatever position of the disk, so the overall Power Consumption is Uniform, while the forces transmitted to the bearings and bushings are stable.

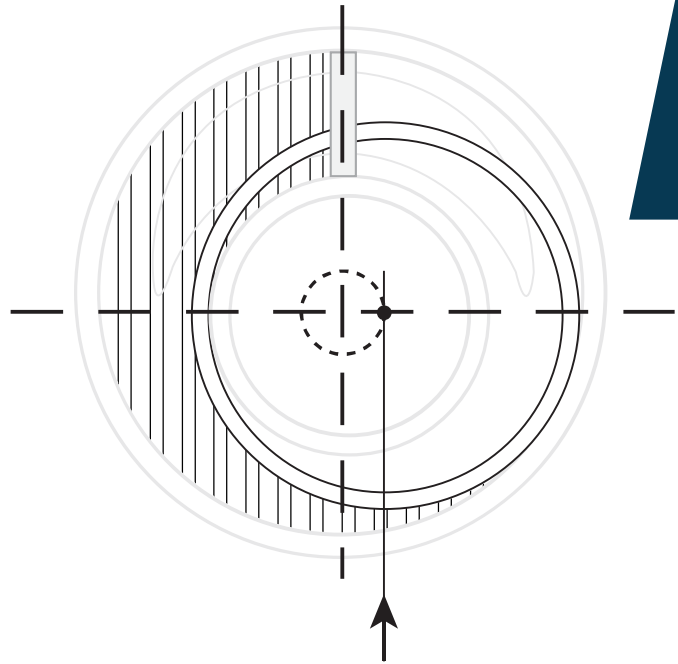

FIGURE SHOWING THE PRESSURE BALANCING IN THE HOLLOW DISK ROTARY PUMP

/ DISK ELASTICITY

Thanks to the Elasticity of the Disk (Spring contained in the Hollow Disk), a certain amount of Solid Particles is tolerated without affecting the pump performances and wear-out.

The Solid Particles can even be quite large, provided that their dimensions do not exceed the available pump internal space or do not clog the cavities and provided that the particles are not capable of damaging the pump internal components.

Higher percentages of Solid Particles could cause a faster Wear Out and consequently a more frequent Maintenance: please contact 3P Prinz in case your application involved Fluids with Solid Particles and we will propose the Most Suitable Pump Version and Execution.

The Elastic Device allows to recover the wear-out effects, by keeping the disk always in contact with the pump enclosure: this means that the Pump Capacity, Head and other Performance are Constant during the operational lifetime, even with particularly viscous or aggressive fluids, or with abrasive effects particles. Thanks to the Elastic Device, the Hollow Disk automatically adapts to a wide range of viscosities. moving radially and creating the appropriate fluid gap. In case of major Temperature Leaps, which create different thermal expansions in the moving and not moving parts of the pump, the Elastic Device allows to adapt the two matching parts instantly.

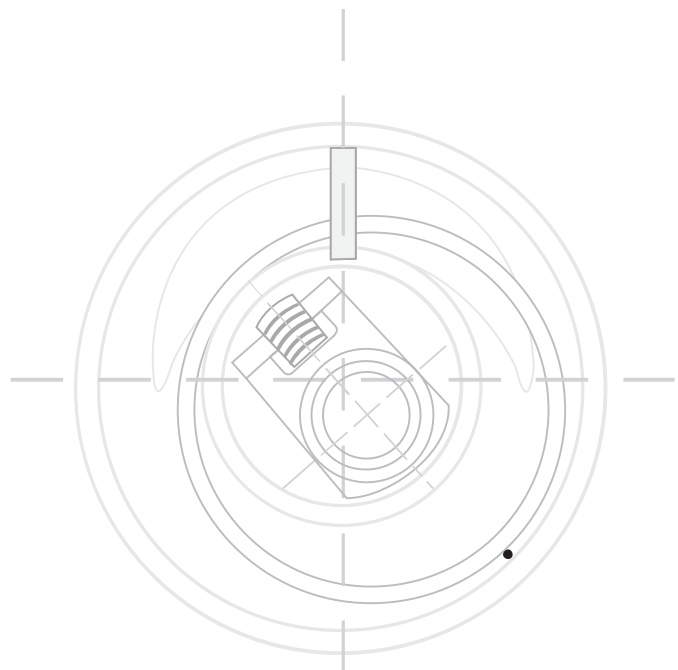

FIGURE SHOWING THE DISK ELASTICITY DEVICE AND THE POSSIBILITY OF HANDLING A SOLID PARTICLE (SMALL BLACK DOT BETWEEN THE HOLLOW DISK AND THE PUMP CASING)

HOLLOW ROTARY DISK

COMPONENTS AND DETAILS



POSITION-DESCRIPTION

- 1 Cover
- 2 Casing
- 3 Base
- 4 Hollow Disk (Impeller)
- 5 Diaphragm
- 6 Impeller Bushing
- 7 Shaft Bushing
- 8 Cap Spring
- 9 Spring
- 10 Shaft
- 11 Mechanical Seal
- 12 Bypass with Relief Valve

HOLLOW ROTARY DISK

SCHEMATIC DRAWING

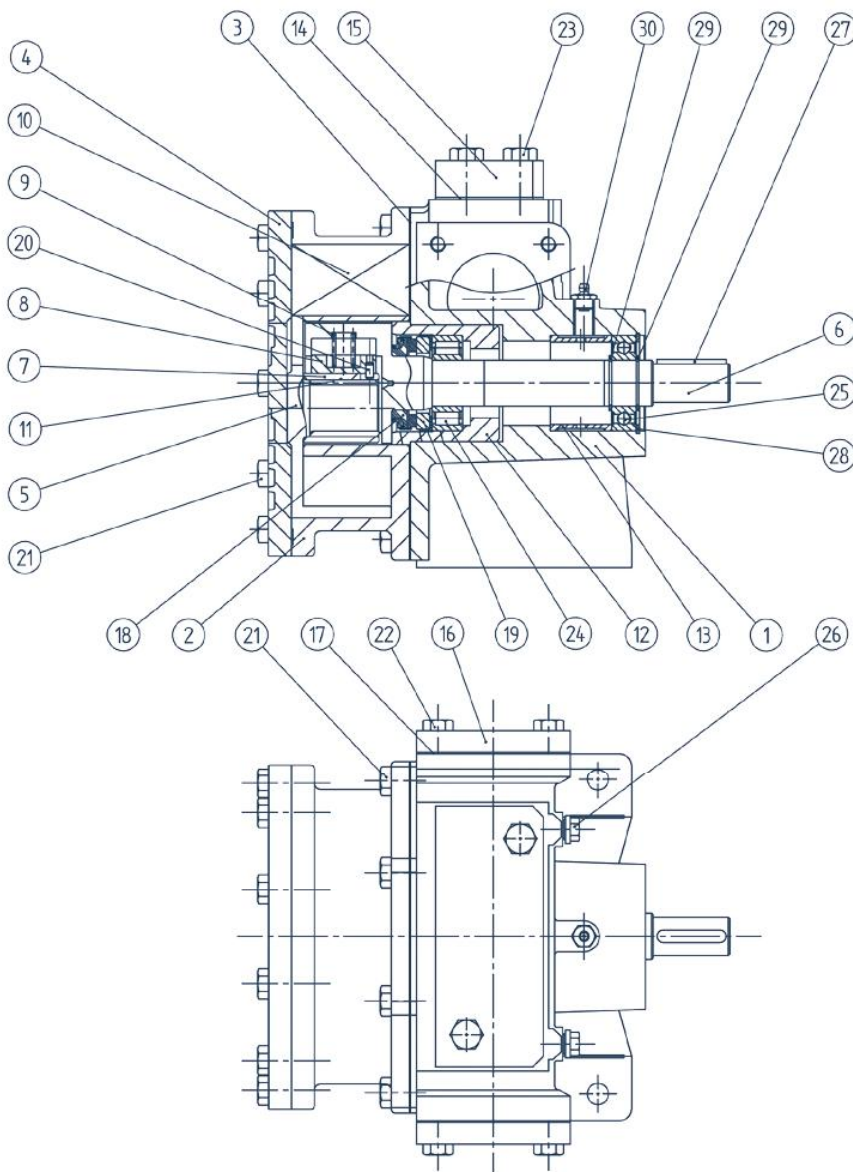

DESCRIPTION	
1	Base
2	Body Pump
3	Base -Body Pump Gasket
4	Cover
5	Impeller
6	Tmv Shaft
7	Bushing
8	Spring Seat
9	Spring
10	Diaphragm
11	Impeller Bush
12	Tmv Case
13	Bearing Specer
14	By-Pass Gasket
15	By-Pass Plate
16	Conter-Flange
17	Counter-Flange Gasket
18	Rotating Ring
19	Stationary Ring
20	Dowel Ø5X10 Uni1707
21	Screw M10X30 Uni5739-65
22	Screw M10X25 Uni5739-65
23	Screw M12X35 Uni5739-65
24	Roller Bearing
25	Ball Bearing
26	Hydraulic Cap 1/4" G
27	Key 8X7X45 Uni6604-69
28	Seeger 62 Uni7437-75
29	Seeger 30 Uni7435-75
30	Hydraulic Lubricator



/ MODULAR CONSTRUCTION

The **Pompe 3P®** Hollow Disk Rotary Pumps have been designed using a Modular Construction Concept. This solution allows to change eventual spare parts with simple maintenance operations, without the need of disassembling the pump from the piping. The pump parts subject to higher wear-out can be changed by simply disassembly the cover from the body (generally connected with bolts), and then disassembling each internal part without the need of any particular tool. The maintenance on this pump is economical and takes short intervention times; the 3P Prinz Genuine Spare Parts are immediately available, allowing the Pump to become as good as new within a very short time and with reduced costs. In addition, most of the Wear-out components of the M Series (with One Disk) and D Series (with Two Disks) are in common, so they can be interchangeable.



/ HIGH RELIABILITY IN SEVERE CONDITIONS AND LOW SPEED OF THE PUMPING ELEMENT

The **Pompe 3P®** Hollow Rotary Disk Pumps operate at a Low Angular Speed and have very little moving parts. This is a guarantee that they are Long-Lasting and Highly Reliable, allowing thus an higher plant reliability too. In addition, their construction assembly does not include any valve, piston, diaphragm, moving seals (except mechanical seals), palettes and other weak components. This peculiarity allows the Pompe 3P® Hollow Rotary Disk Pumps to be used in highly severe conditions and with very high viscosity products.

0-500 Rpm.

/ HIGH EFFICIENCY

The **Pompe 3P®** Hollow Rotary Disk Pumps have the highest Efficiency that can be obtained, particularly thanks to their construction simplicity: They need only two supports, they operate at low angular speeds, there is only Rolling Friction (no Sliding Frictions), the Pressures are balanced.

The Volumetric Efficiency η_v is very high (see below figure) and is generally between 75% and 90% along all the complete operational range of Flow Rates, Heads and Viscosities.

This high efficiency has been achieved thanks to high machining tolerances, long-year experience, proven design and extensively tested assemblies, accurate study of each component and cavities design, oversizing of the parts, accurate sizing of the elastic device.

The Overall Efficiency η , on a Pump with max 8 bar operating pressure, has its maximum in the pressure range between 4 and 5 bar and can be 60% or higher (depending also on the pump size).

This advantage brings, particularly on the D Series Pumps (with Double Hollow Disk Construction), a better usage of the Installed Power and the Smaller Power Consumption compared to other pump types that have equivalent performances.

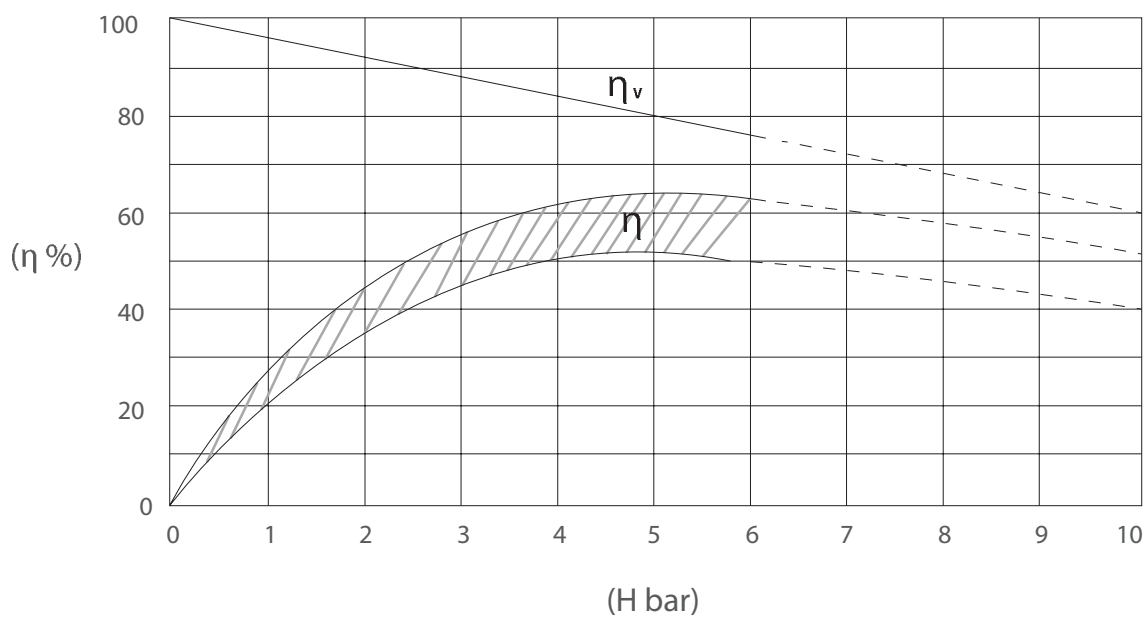

FIGURE ABOVE: VOLUMETRIC EFFICIENCY η_v AND OVERALL EFFICIENCY η ON POMPE 3P® HOLLOW ROTARY DISK PUMPS

INDUSTRIES SERVED & APPLICATION FIELDS HOLLOW ROTARY DISK PUMPS

The particular construction of the **Pompe 3P®** Hollow Rotary Disk Pumps allows them to be used in a very wide range of applications:

- From Very Volatile up to Very High Viscosity Fluids
- From Lubricating Oils up to Dry Fluids that could cause Seizing of the moving parts
- Fluids with Abrasive Particle Contents
- Aggressive and Corrosive Fluids
- Food and Beverage Products

In particular applications, in which the fluid can be pumped only when heated, the Pompe 3P® Hollow Rotary Disk Pumps can be provided with Heating Jacket, in which Diathermic Oil or Warm Water or Steam can flow.

The Pompe 3P® Hollow Rotary Disk Pumps are ideal for the following Industries:

Petrochemical, Chemical, Marine and Shipbuilding, Oil&Gas (on Auxiliary Pumping Services), Pulp & Paper, General Industry, Food & Beverage and Pharmaceutical.

The Pompe 3P® Hollow Rotary Disk Pumps have a wide range of applications that include the following:

	MAIN APPLICATION FIELDS		
Petrochemical Industry	Light and Heavy Hydrocarbons	Lubricating Oil	Bitumen and Tar
	Benzene and Toluene	Gasoline	Phenol
	Diesel	Fuel Oil	Crude Oil
	Fluids from the Refinery Process	Petrochemical Products	All types of Oils
Chemical Industry	Acids and Concentrated Acids	Solvents	Lubricating Oils
	Aliphatic and Sulphuric Acids	Additives	Wax
	Glycerin	Latex	Polyoils
	Glues	Alkaline Solutions	Emulsions
	Soaps and Detergents	Caustic Soda	Solvents
	Liquid Sulfur	Rubber Suspensions	Paraffin
	Plasticizers	Starches	Oily muds
	Polymers / Fibers Suspensions	Polyester	Resins
Marine and Shipbuilding	Transfer of Tanker Fluids	Fuel Oil	Diesel
	Bilge Water	Mud, Sludge, Ooze	Seawater
	Recycled Oil	Waste Oil	Sewage
	Cargo Load and Offload	Service Fluids and Water	Residues
Oil & Gas (Auxiliary Pumping Services)	Chemical Products	All types of Oils	Crude Oil
	Light and Heavy Hydrocarbons	Bitumen and Tar	Muds
Pulp & Paper	Acid Water	Iso-cyanate	Caustic Soda
	Mud	Several Process Fluids	Starch
	Cellulose / Fibers Suspensions	Glues	Fuel Oils
General Industry	Colouring, Inks & Pigmented Pastes	Thickeners	Additives
	Industrial Water	Lye	Sewage
	Enamels and Paints	Emulsions	Lime
Food & Beverage and Pharmaceutical	Vegetable and Animal Oils	Fruit Juices, Pastes, Jam	Syrups and Molasses
	Animal Fats	Lecithin	Cream
	Alcohol & Liquors	Chocolate	Caramel and Fudge
	Sauces and Dough	Dairy Products	Wines

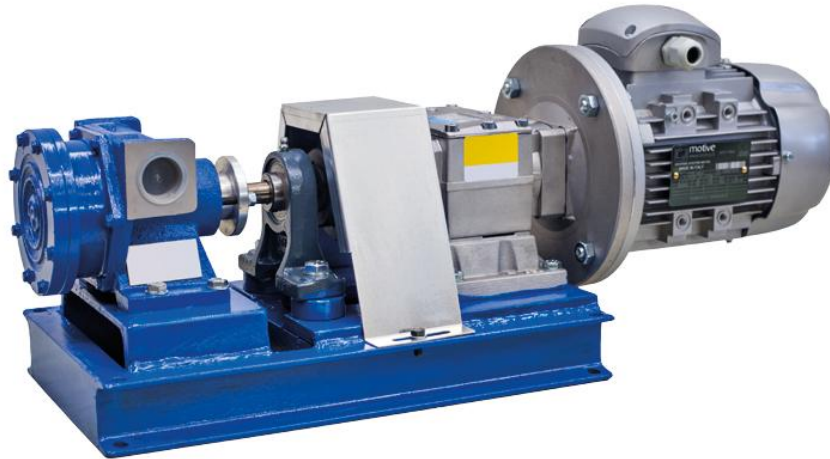

Hollow Rotary Disk Pump M Series

Chemical & Petrochemical, Marine & Ship Building, Oil & Gas, Food & Beverage, Pharmaceutical, Pulp & Paper, Paint Industry, General Industry

This type of pump with single impeller is ideal to transfer liquids with medium, high and very high viscosity containing also small amounts of suspended solids.

The hollow disk M series, during its rotary-oscillating motion, causes a vacuum, sucking the fluid inside the pump; in the meantime, it pushes the fluid already present in the chamber to the downstream pipe. Because of their particular features, **3P Prinz®** hollow disk pumps are recommended for pumping liquids with low, medium, high or very high viscosity even in presence of moderate contents of solid particles in suspension.

M Series Hollow Rotary Disk Pump Main Specification	
Maximum manometric head:	8 bar [116 PSI] - option 12 bar [174 PSI] or 20 bar [290 PSI]
Flow rates:	from 0,3 to 100 m ³ /h [from 1.3 to 440 GPM]
Viscosity of the pumped fluid:	up to 200.000 cSt (from medium to very high)
Pipe Nominal Size DN:	from 25 to 150
Rotation speed:	up to 500 rpm
Temperature range:	-20 / +280 °C [-4 / 536 °F]
Handling Solid Particles & Dirty Fluids:	Yes
Handling Aggressive Fluids:	Yes
Pulsations:	Yes
Dosing capability:	Good
Flanged connections:	UNI PN10 ANSI 150 DIN PN 16
Bearing types:	Bearings + Bushings
Seal types available:	- Mechanical Seals - DIN 24960 Unified Mechanical Seals - Packing type Seals - Cartridge type Seals - Double Mechanical Seals - Double Viton Radial Seals - Seals flushed to API PLANS - MAG Magnetic Drive - JOHN CRANE Seals on request

Advantages and Main Features:

1. *Self Priming without any auxiliary devices*
2. *Disk's Elasticity*
3. *Low operating speed*
4. *Reverse flow by operating in reverse rotation and keep constant capacity*



Hollow Rotary Disk Pump D Series

Chemical & Petrochemical, Marine & Ship Building, Oil & Gas, Food & Beverage, Pharmaceutical, Pulp & Paper, Paint Industry, General Industry

These pumps, with two impellers, are ideal to transfer fluids with medium and high viscosity and are designed to be used with piping, valves, fittings, etc..

These pumps, with two impellers, allow a reduced size of the piping, valves, fittings etc. while keeping a high flow rate: thanks to the phased movement of the two disks, they create a continuous flow in the piping, avoiding vibrations and shaking of the structure.

The phased-disks concept allows to optimize the flow rate at its highest value, reducing the pulsation peaks and allowing the use of smaller piping, valves etc. compared to the ones that would be needed on another positive displacement pump. The electrical motor is generally coupled directly to the pump in which, into its casing, an oil filled reduction gear is assembled.

The hollow disk D series, during its rotary-oscillating motion, causes a vacuum sucking the fluid inside the pump; in the meantime, it pushes the fluid already present in the chamber to the downstream pipe. Because of their particular features, **3P Prinz®** hollow disk pumps are indicated for pumping liquids with low, medium, high or very high viscosity even in presence of moderate contents of solid particles in suspension.

D Series Hollow Rotary Disk Pump Main Specification	
Maximum manometric head:	8 bar [116 PSI] - option 12 bar [174 PSI] or 20 bar [290 PSI]
Flow rates:	from 20 to 250 m ³ /h [from 88 to 1100 GPM]
Viscosity of the pumped fluid:	up to 200.000 cSt (from medium to very high)
Pipe Nominal Size DN:	from 100 to 200
Rotation speed:	up to 500 rpm
Temperature range:	-20 / +280 °C [-4 / 536 °F]
Handling Solid Particles & Dirty Fluids:	Yes
Handling Aggressive Fluids:	Yes
Pulsations:	Very low
Dosing capability:	Good
Flanged connections available:	UNI PN10 - ANSI 150 - DIN PN 16
Bearing types:	Bearings in oil bath
Seal types available:	- Mechanical Seals - Double Viton Radial Seals - Other types of Seals are available for the double impeller version on the "DN" Series

Advantages and Main Features:

1. *Self Priming without any auxiliary devices*
2. *Disk's Elasticity*
3. *Low operating speed*
4. *Reverse flow by operating in reverse rotation and keep constant capacity*

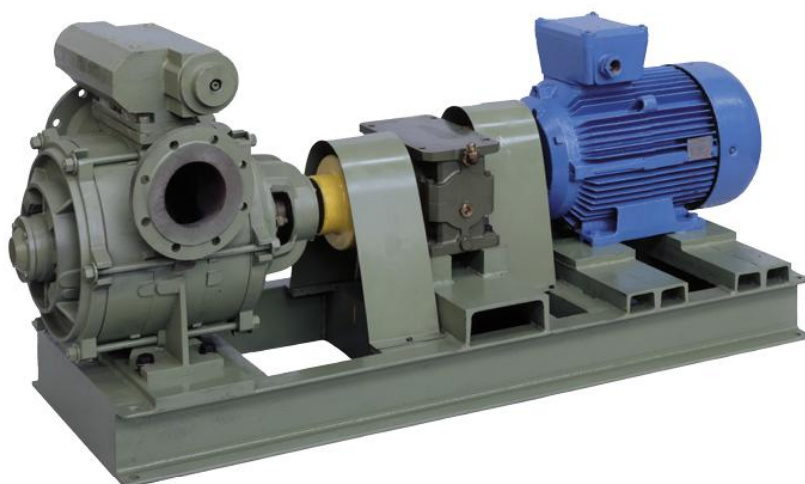

Hollow Rotary Disk Pump DN-CN-MN Series

Chemical & Petrochemical, Marine & Ship Building, Oil & Gas, Food & Beverage, Pharmaceutical, Pulp & Paper, Paint Industry, General Industry

Pumps with one or two impellers equipped with external bearings and special innovative and patented technical features, which enable these pumps to be widely employed in fields with special plant requirements.

These pumps, with single or double impeller are characterized by external bearings and special technical and patented innovations, in order to make them more performing in areas with special installation requirements. They are suitable for the transfer of fluids even at very high viscosities, containing small amounts of suspended solids. Generally, DN-CN-MN Series Pumps are supplied with motor or variable speed drive and mounted on a suitable skid.

The hollow disk DN-CN-MN series, during its rotary-oscillating motion, causes a vacuum sucking the fluid inside the pump; in the meantime, it pushes the fluid already present in the chamber to the supply pipe. Because of their particular features, **3P Prinz®** hollow disk pumps are recommended for pumping liquids with low, medium, high or very high viscosity even in presence of moderate contents of solid particles in suspension.

DN-CN-MN Series Rotary Disk Pump Main Specification	
Maximum manometric head:	8 bar [116 PSI] - option 12 bar [174 PSI] or 20 bar [290 PSI]
Flow rates:	from 0 to 90 m ³ /h [from 0 to 396 GPM]
Viscosity of the pumped fluid:	up to 200.000 cSt (from medium to very high)
Pipe Nominal Size DN:	from 65 to 125
Rotation speed:	up to 500 rpm
Temperature range:	-20 / +280 °C [-4 / 536 °F]
Handling Solid Particles & Dirty Fluids:	Yes
Handling Aggressive Fluids:	Yes
Pulsations:	Only DN series: very low
Dosing capability:	Good
Flanged connections available:	UNI PN10 - ANSI 150 - DIN PN 16
Bearing types:	Special and patented executions; bearings in oil bath on DN series
Seal types available:	<ul style="list-style-type: none"> - Mechanical Seals - DIN 24960 Unified Mechanical Seals - Packing type Seals - Cartridge type Seals - Double Mechanical Seals - Double Viton Radial Seals - Seals flushed to API PLANS - JOHN CRANE Seals on request - MAG Magnetic Drive - Special Seals Executions



Hollow Rotary Disk Pump TURBIK Series

Food&Beverage, Marine & Ship Building, Chemical & Petrochemical, General Industry, Paint Industry

These pumps, with two impellers, are ideal to transfer fluids with medium and high viscosity and are designed to be used with piping, valves, fittings, etc..

The hollow rotary disk Turbik series, during its rotary-oscillating motion, causes a vacuum sucking the fluid inside the pump; in the meantime, it pushes the fluid already present in the chamber to the downstream pipe. Because of their particular features, **3P Prinz®** hollow disk pumps are indicated for pumping liquids with low, medium, high or very high viscosity even in presence of moderate contents of solid particles in suspension.

Turbik Series Hollow Rotary Disk Pump Main Specification	
Maximum manometric head:	4 bar [58 PSI]
Flow rates:	up to 3 m ³ /h [up to 13 GPM]
Viscosity of the pumped fluid:	up to 3.000 cSt (from medium to high)
Pipe Nominal Size DN:	Suction NPS 1.1/2" - Outlet NPS 1"
Rotation speed:	up to 950 rpm
Temperature range:	0 / +100 °C [32 / 212 °F]
Handling Solid Particles & Dirty Fluids:	Yes
Handling Aggressive Fluids:	Yes
Pulsations:	Yes
Dosing capability:	Good
Connections:	Standard: Threaded Connection GAS ; Available NPT-F and BSPP Threaded Connections
Bearing types:	Bearings + Bushings

Advantages and Main Features:

- 1. Self Priming without any auxiliary devices*
- 2. Disk's Elasticity*
- 3. Low operating speed*
- 4. Reverse flow by operating in reverse rotation and keep constant capacity*

/ STANDARD MATERIALS FOR HOLLOW ROTARY DISK PUMPS

The Selection of the Materials originates from the Handled Service Fluid, Temperature Range and Surrounding Environmental Conditions.

Combinations	<i>Casing and Cover</i>	<i>Impeller Disk</i>	<i>Shaft</i>
	Cast Iron G25	Carbon Steel C40	Carbon Steel C40
	Cast Iron G25	Stainless Steel AISI 316	Stainless Steel AISI 316
	Cast Iron, Nickel Plated	Nickel Plated Carbon Steel C40	Stainless Steel AISI 316
	Cast Iron, Chrome plated	Chrome plated Carbon Steel C40	Nitrided Carbon Steel C40
	Ni-Resist Cast Iron	Carbon Steel C40	Carbon Steel C40
Standard Materials	Ni-Resist Cast Iron	Stainless Steel AISI 316	Stainless Steel AISI 316
	Stainless Steel AISI 304	Nitrided Stainless Steel AISI 316	Stainless Steel AISI 316
	Bronze B10	Stainless Steel AISI 316	Stainless Steel AISI 316
	Duplex Stainless Steel	Duplex Stainless Steel	Duplex Stainless Steel
	Super Duplex S. Steel	Super Duplex S. Steel	Super Duplex S. Steel
	Nickel Aluminium Bronze	Monel	Monel
	Hastelloy	Hastelloy	Hastelloy
	Inconel®	Inconel®	Inconel®
	Titanium	Titanium	Titanium
Special Trim Hardening Coatings	HVOF Spray Coated	HVOF Spray Coated (Tungsten Carbide or Chromium Carbide)	
Customized materials	Other Alloys and Material Combinations are available on request		

Special Executions and Materials

3P Prinz® is able to manufacture the entire range of products with special materials for pump wetted parts. Starting from cast iron to all the special Alloys, like Inconel®, Hastelloy®, Alloy 20 or Duplex / Super Duplex. The material selection depends from the service fluid, the temperature and the external environment.

/ SEAL TYPES

The **POMPE 3P®** Hollow Rotary Disk Pumps can be supplied with many Seal types. They can be fitted with Packing type Seals (Stuffing Boxes), Internal or External Mechanical Seals, Double Viton Radial Seals, every type of Unified Mechanical Seal, Single or Dual, or with Flushing Systems in accordance with the API PLANS, or with or even with not unified Seals, like the Cartridge type.

Standard seals types	Internal Mechanical Seals Viton/Graphite/Stainless Steel or Ceramic
	Internal Mechanical Seals Teflon/Widia/Widia
	DIN 24960 Unified External Mechanical Seals Viton or Teflon/Widia/Widia
	DIN 24960 Unified External Mechanical Seals Viton or Teflon/Graphite/Stainless Steel
	Double Viton Radial Seal
	Internal Mechanical Seal FLUITEN or MICROTEM or JOHN CRANE (on request)
	Braided Teflon filled Packing type Seal (for very high viscosities)
	Single and Double Mechanical Seal Cartridge type
	Other Seal Types and Executions upon request
MAGNETIC DRIVE – MAG DRIVE – IS AVAILABLE	

Seal Flushing can be executed in accordance with the following API 610 PLANS:

Plan 2 – Plan 11 – Plan 12 – Plan 13 – Plan 31 – Plan 32 – Plan 52 – Plan 53 – Plan 54 – Plan 61 – Plan 62

SOME TYPICAL SEALS DRAWINGS FOR THE POMPE 3P HOLLOW ROTARY DISK PUMPS

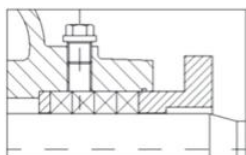

Figure 1: Packing type Seal

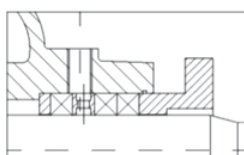

Figure 2: Packing type Seal with Flushing

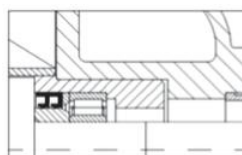

Figure 3: Double Radial Seal

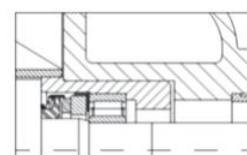

Figure 4: Internal Mechanical Seal

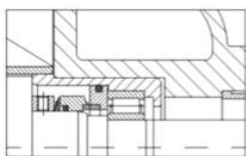

Figure 5: Internal Mechanical Seal

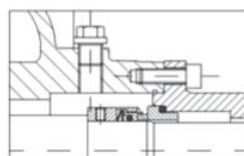

Figure 6: Unified Mechanical Seal

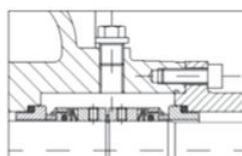

Figure 7: Double Mechanical Seal - with Flushing

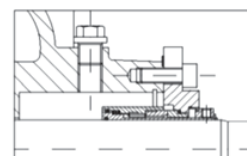

Figure 8: Cartridge type Mechanical Seal

/ THE SCOPE OF SUPPLY IS NOT LIMITED TO THE PUMPS

3P Prinz® supplies:

- Pump Unit, with or without Base Plate
- Pump with Reduction Gear or Variable Speed Drive, Motor and Base Plate

3P Prinz® also supplies:

1. Skid type base frames or custom skid mounted
2. Instrumentation
3. On-Skid Piping with Valves and Accessories
4. Control equipment
5. Monitoring devices
6. Auxiliary equipment

OPTIONAL EXECUTIONS FOR THE POMPE 3P® HOLLOW ROTARY DISK PUMPS

MAG DRIVE Magnetic Drive: Total absence of any liquid leakage thanks to the magnetic drive. Suitable for dangerous and toxic media
In accordance with API standard
High Pressure Version (12 Barg or 20 Barg)
Heating or Cooling Jacket
Custom Made Enclosure
Custom Made Baseplate
Diesel Engine
Inlet Filter (in line or bowl type)
Pressure, Electric, Electronic and Digital Instrumentation (Brands and Models can follow specific requests from the Customer)
Electrical Control and/or Monitoring Cabinet (customizable and in several materials)
Cart-mounted version
Fast & Easy Inspectable Access to Internals
Skid complete with Piping, Manifolds, Valves and Accessories
High Performance and Long Life Mechanical Seals and Double Mechanical Seals
Special Execution for low or high Temperatures and / or Harsh Ambient Temperatures
Executions with a double seal combination with flushing or recirculation In accordance with the required API PLANS

CERTIFICATIONS	
Products:	Electrical Group:
Standard Execution: CE	Standard Execution: CE and ATEX
On Request:	On Request:
ATEX	IECEX
API	UL / FM or CSA or AUS
Vibration Test	NEMA
Noise Level Test	Others on request (Diesel Engines etc.)

On the Materials:

- ISO EN 10204-2.1
- ISO EN 10204-2.2
- ISO EN 10204-3.1
- ISO EN 10204-3.2

MAG MAGNETIC DRIVE





3P Prinz® Hollow Rotary Disk Pumps can be supplied on request with the Magnetic Drive instead of any Mechanical Seal.

The Magnetic Drive transmits the movement from the Motor to the Pump Shaft thanks to the coupling of powerful Magnets placed outside and inside the enclosure and matched together.

The external and internal rotors are completely environmentally isolated thanks to the Magnetic Drive Enclosure – there is no contact between the internal and external moving mechanical parts, and the pumped fluid is totally isolated from the external environment.

This feature makes the Magnetic Drive a Perfect Solution for handling Dangerous or Toxic Fluids that are not allowed to be emitted into the Environment.

MAG Magnetic Drive

-  Enclosure
-  External Magnetic Rotor
-  Pump Shaft
-  Internal Magnetic Rotor

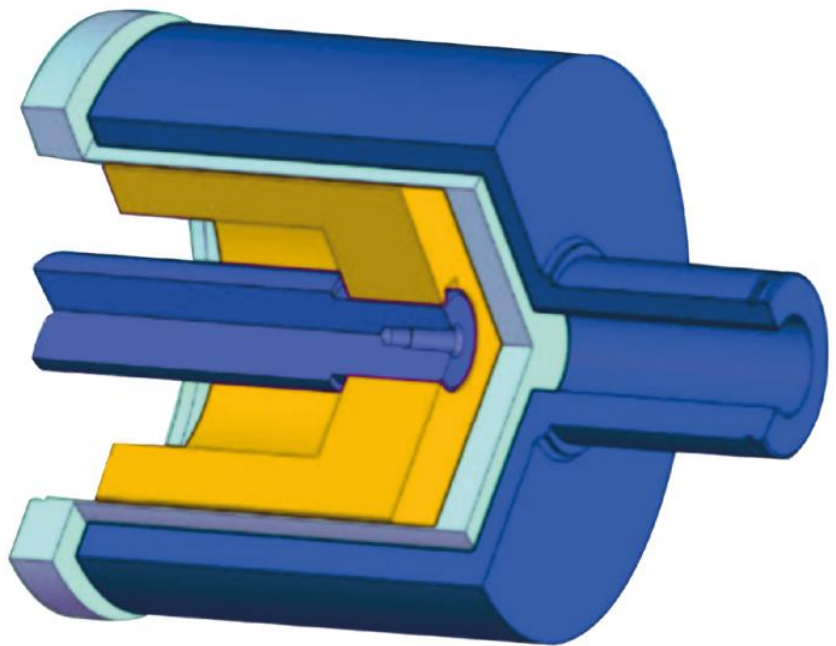

SIZING CRITERIA

SHORT EXPLANATION ON HOW THE HOLLOW ROTARY DISK PUMPS ARE SIZED.

1) Choice of the number of revolutions of the pump

The tables below, based on the viscosity of the fluid, are giving optimal revolutions that the pump must make in percentage of the number of revolutions standard. If the viscosity is less than 30 ° E, the spins correspond to the optimum RPM standard.

PUMP TYPE	Ø	rpm		PUMP TYPE	Ø	rpm	
		Piping	Std.			Piping	Std.
3P - 25 M	1"		340				
3P - 35 M	1" 1/4		340				
3P - 50 M	2"		260				
3P - 60 M	2" 1/2		290				
3P - 80 M	3"		290				
3P - 100 M	4"		240	3P - 225 MN	4"		290
3P - 80 D	4"		340				
3P - 100 D	5"		300	3P - 225 DN	5"		340
3P - 125 D	6"		255				
3P - 160 D	8"		230				

Revolutions that the pump needs to make in % of the standard rpm.

Percentage of RPMs on fluid Viscosity (cSt)

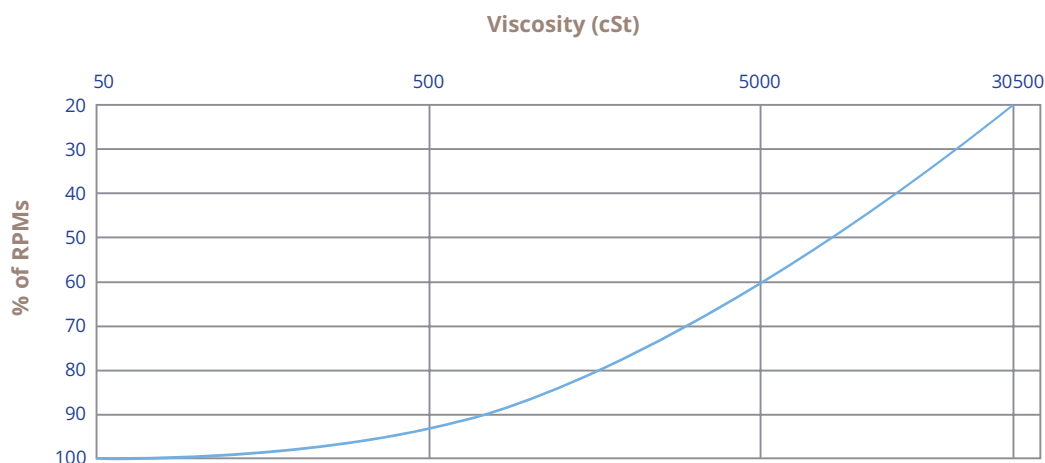

SIZING CRITERIA

SHORT EXPLANATION ON HOW THE HOLLOW ROTARY DISK PUMPS ARE SIZED.

2) Calculation of flow rate and power consumption

After finding the optimal number of turns, you go to see the tables below to determine the size of the pump, the actual flow rate and power consumption, depending on the total manometric head.

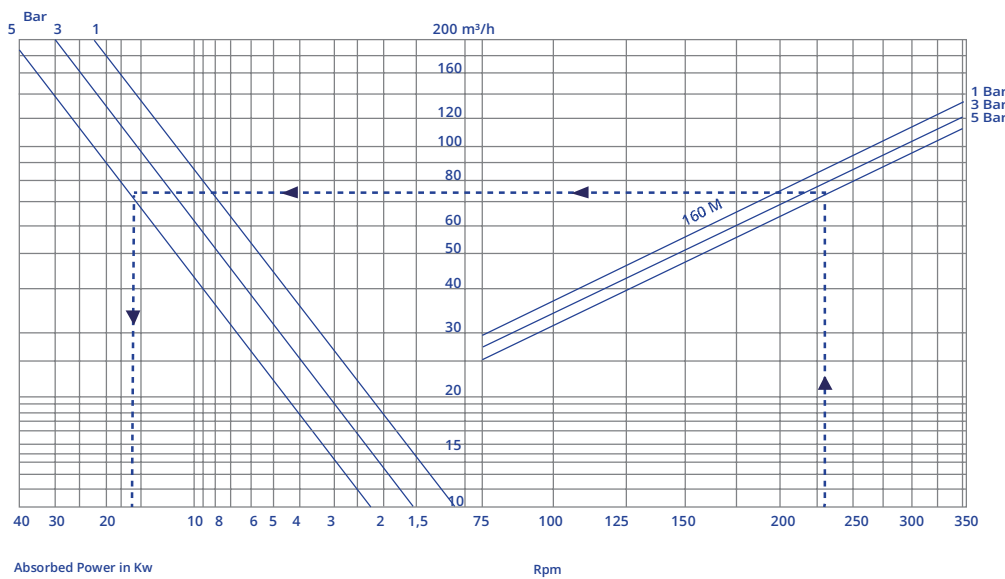
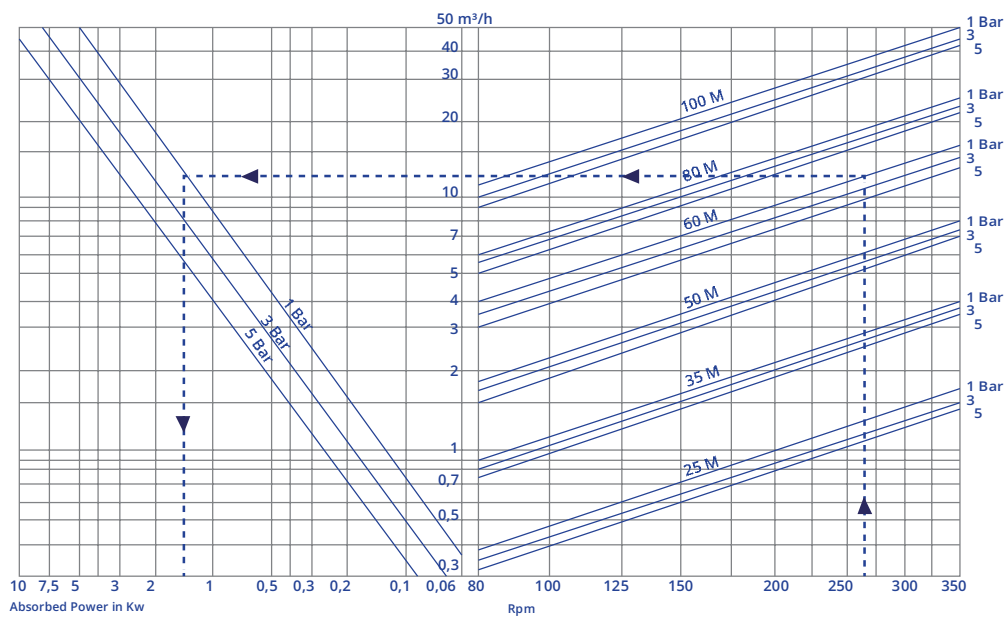

SIZING CRITERIA

SHORT EXPLANATION ON HOW THE HOLLOW ROTARY DISK PUMPS ARE SIZED.

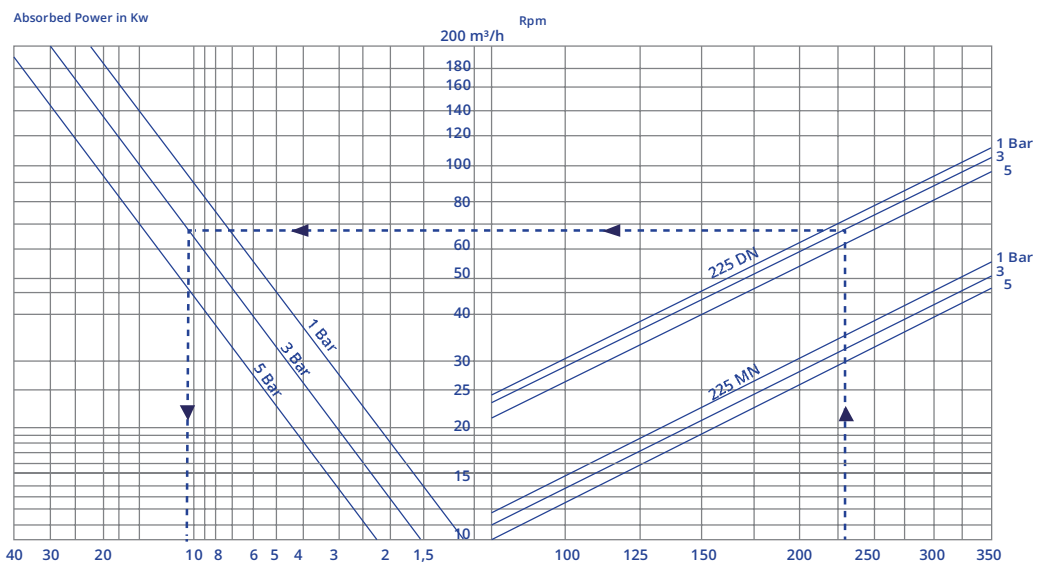
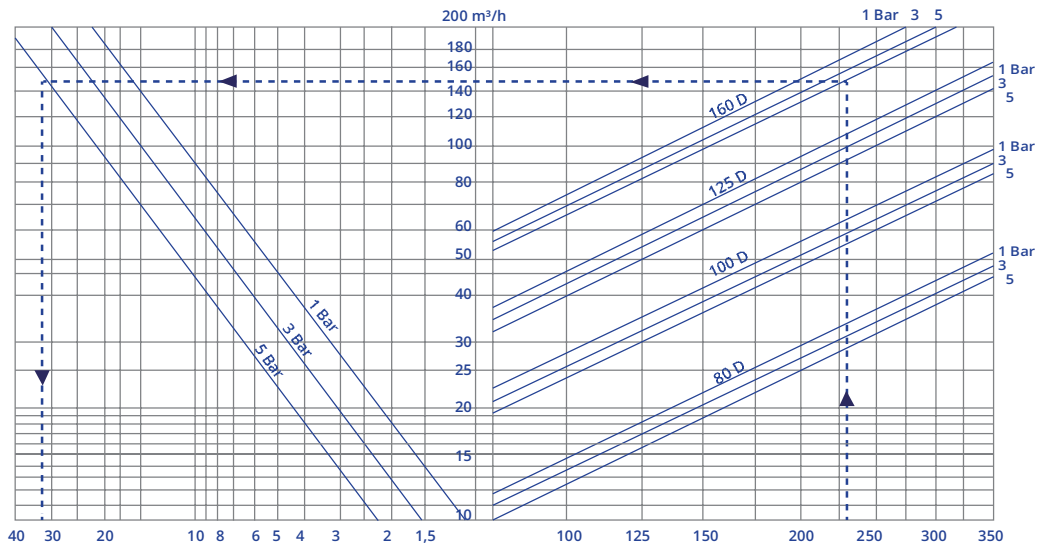

Absorbed Power in Kw

Rpm

3) Choice of construction materials

All components of both the pumps and the seals can be manufactured in different materials, depending on the chemical and mechanical characteristics of the fluid to be pumped. Those normally used are the following:

Base: Cast Iron, Bronze , Cast Iron/Nickel Resist

Bushings: Bronze , Cast Iron Nickel

Body: Cast Iron, Bronze , Cast Iron/Nickel Resist, Stainless Steel

Shirt: Stainless Steel, Chrome Steel

Supports: Cast Iron, Bronze , Cast Iron/Nickel Resist

Gaskets seal: Viton, PTFE

Cover: Cast Iron , Bronze , Cast Iron/Nickel Resist, Stainless Steel

Rotating ring seal: Graphite , Ceramic, Tungsten Carbide

Impeller: Steel, Stainless Steel, Nickel-plated steel

Stationary seal ring: Stainless Steel , Ceramic, Tungsten Carbide

Shaft: Steel, Stainless Steel

***Special versions can be supplied on request**

/ SPECIAL VERSIONS

M1 Series Inspectable

Series M pump with special design to enable easy access and internal inspection for the fastest maintenance possible.

Request More Info: sales@3pprinz.com



D Series with coupling and distanced electric motor

These pumps, with two impellers, are ideal to transfer fluids with medium and high viscosity and are designed to be used with piping, valves, fittings, etc. They are supplied with electric motor.

Request More Info: sales@3pprinz.com



Cart-mounted Series D pump with diesel motor

These pumps, with two impellers, are ideal to transfer fluids with medium and high viscosity and are designed to be used with piping, valves, fittings, etc. They are supplied with cart mounting and diesel motor.

Compliance to several Standards is available on request.

Request More Info: sales@3pprinz.com



Cart-mounted filtering unit

Cart-mounted Pump system, functioning as a filtering unit.

Request More Info: sales@3pprinz.com



/ SPECIAL VERSIONS



Series M motor driven pump with variable turn speed drive

Series M motor driven pump with variable turn speed drive. This allows the pumps to work at different speeds and handling a wide range of fluid viscosities at their best performances, by using only one pump.

Request More Info: sales@3pprinz.com

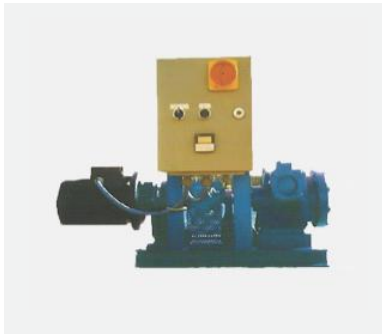

Series M motor-driven pump with pre-determining system

Series M motor-driven pump with pre-determining system

Request More Info: sales@3pprinz.com



Series M engine mono-block motor-driven pump

Series M engine block motor-driven pump

Request More Info: sales@3pprinz.com

Visit site

www.3pprinz.com



HOLLOW ROTARY DISK PUMPS

OVERALL DIMENSIONS FROM 3P/25M UP TO 3P/100M

/ M-Series pumps with basement

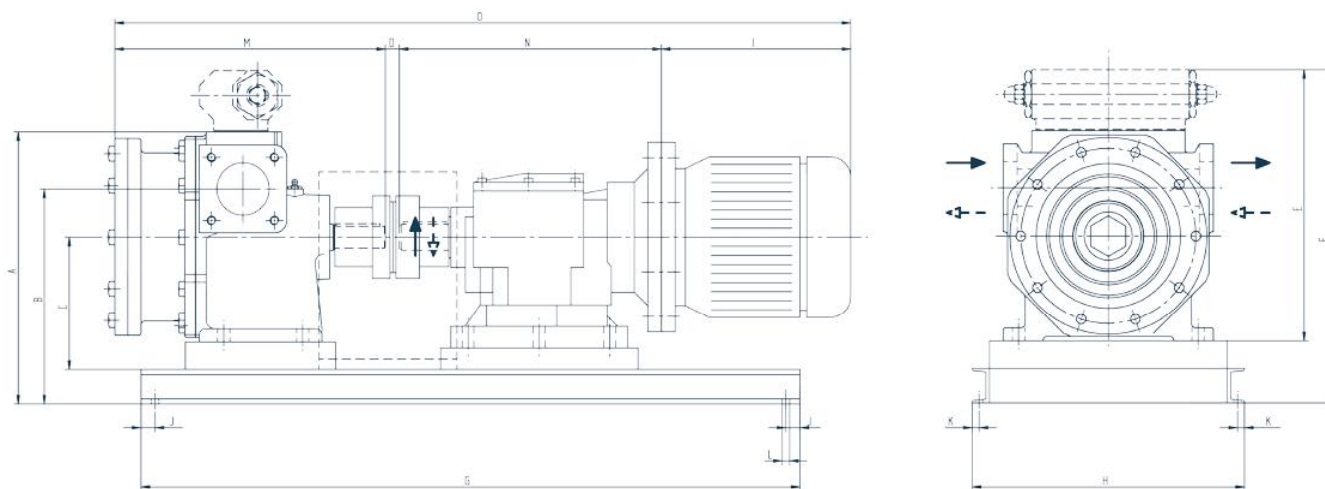

PUMP TYPE	OVERALL DIMENSIONS (mm)															VOL. EL. MOTOR		
	A	B	C	D	E	F	G	H	I	J	K	L	M	N	O	l/rev.	Kw	n.pole
25 M	201	174	65	2	-	-	340	230	211	10	10	10	159	171	543	0,085	0,37	4
35 M	237	179	80	2	201	265	420	230	231	10	10	10	203	191	627	0,200	0,75	4
50 M	279	209	100	2	254	318	500	316	270	15	15	14	265	231	768	0,410	1,5	4
60 M	316	229	120	3	308	362	550	326	304	15	15	14	300	264	871	0,840	2,2	4
80 M	396	294	140	3	364	458	600	390	304	20	20	16	296	264	867	1,336	3	4
80 M	396	294	140	3	364	458	600	390	364	20	20	16	296	350	1013	1,336	5,5	4
100 M	464	339	170	3	430	529	700	450	364	20	20	16	382	340	1089	2,527	5,5	4
100 M	464	339	170	3	430	529	700	450	402	20	20	16	382	340	1127	2,527	7,5	4

HOLLOW ROTARY DISK PUMPS

OVERALL DIMENSIONS FROM 3P/25M UP TO 3P/160M

/ M-Series pumps with mechanical seal

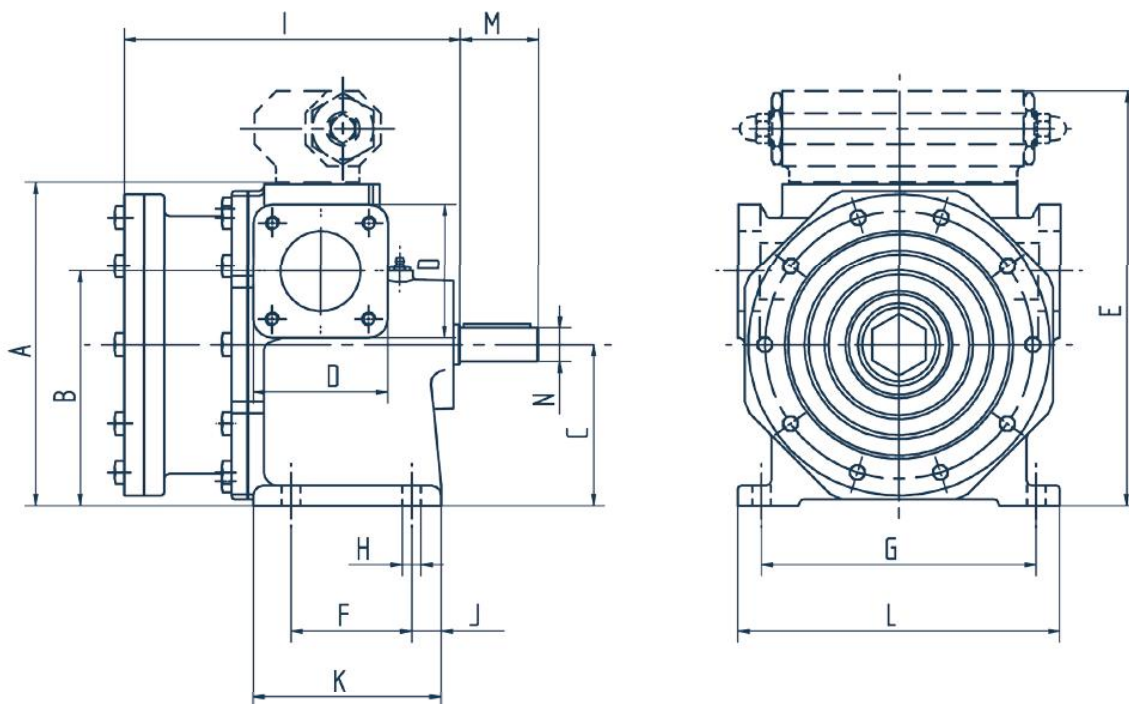

OVERALL DIMENSIONS (mm)														
PUMP TYPE	A	B	C	D	E	F	G	H	I	J	K	L	M	N
25M	120	93	65	50	/	45	110	9	131	12	78	125	28	14
35M	173,5	115	80	70	202,5	55	145	11	167,5	15	97	170	36	18
50M	215,5	145	100	90	253,5	85	185	12	220,5	17	134	215	45	22
60M	261,5	175	120	100	307,5	90	205	14	250	22	144	240	50	25
80M	301,5	200	140	120	363,5	80	250	16	245,5	22	142	300	50	30
100M	364,5	240	170	150	429,5	135	300	16	322	18	190	350	60	38
160M	500	344	240	210	605	210	450	17	451	30	280	500	80	48

Visit site

www.3pprinz.com



Reliable
Efficient & Performance
Pumps Manufacturing
Company

Since 1952



PERA-PRINZ®

Pera-Prinz® is a trademark of 3P Prinz® srl



3P Prinz

3P PRINZ is based in Tuscany, Italy, 3P Prinz is a pumps manufacturing company. The company is highly-specialized in engineering products and innovative technology, serving the demands of customers worldwide. 3P Prinz is the owner for the following Brands:

Pompe 3P - Hollow rotary disk and Gear Pumps

Pera-Prinz - Screws pumps

We believe that After sales service, reliability and efficiency are the base in this type of products and industry. The pumps selection is based on cost-effective and energy-efficient pumping solutions. Strong of its 60 years spent supplying Italy's top refineries, chemical, petrochemical, ship building, ecological and food industries, 3P Prinz has become an undisputed benchmark of quality and service. Our richness is based on customers that require perfection, personalization, promptly! We fulfill our customer's requirements and our customers fulfill our desire of growth at a steady rate!

Genuine spare parts

Base on 3P Prinz culture and philosophy the pumps reliability and life is base of a good investment.

In many case the pumps are the heart of the plant, so the efficiency is extremely important in order not to slow down the production process.

3P Prinz is able to ship spare parts worldwide within 48 hours.

Quality Assurance & Quality Controls (QA/QC)

3P Prinz commits to Quality.

The Quality assurance and Quality Controls are registered and independently audited to the ISO 9001 standard.

3P Prinz is certified by CSI.

For Enquiries or Further Information please contact: sales@3pprinz.com



Visit site

www.3pprinz.com





**For Enquiries or Further Information please
contact:**

sales@3pprinz.com

Visit our Website:

www.3pprinz.com







/ 3PPrinz®

Made in Tuscany, Italy

sales@3pprinz.com

www.3pprinz.com

Pompe 3P® and Pera-Prinz® are trademarks of 3P Prinz® srl

