

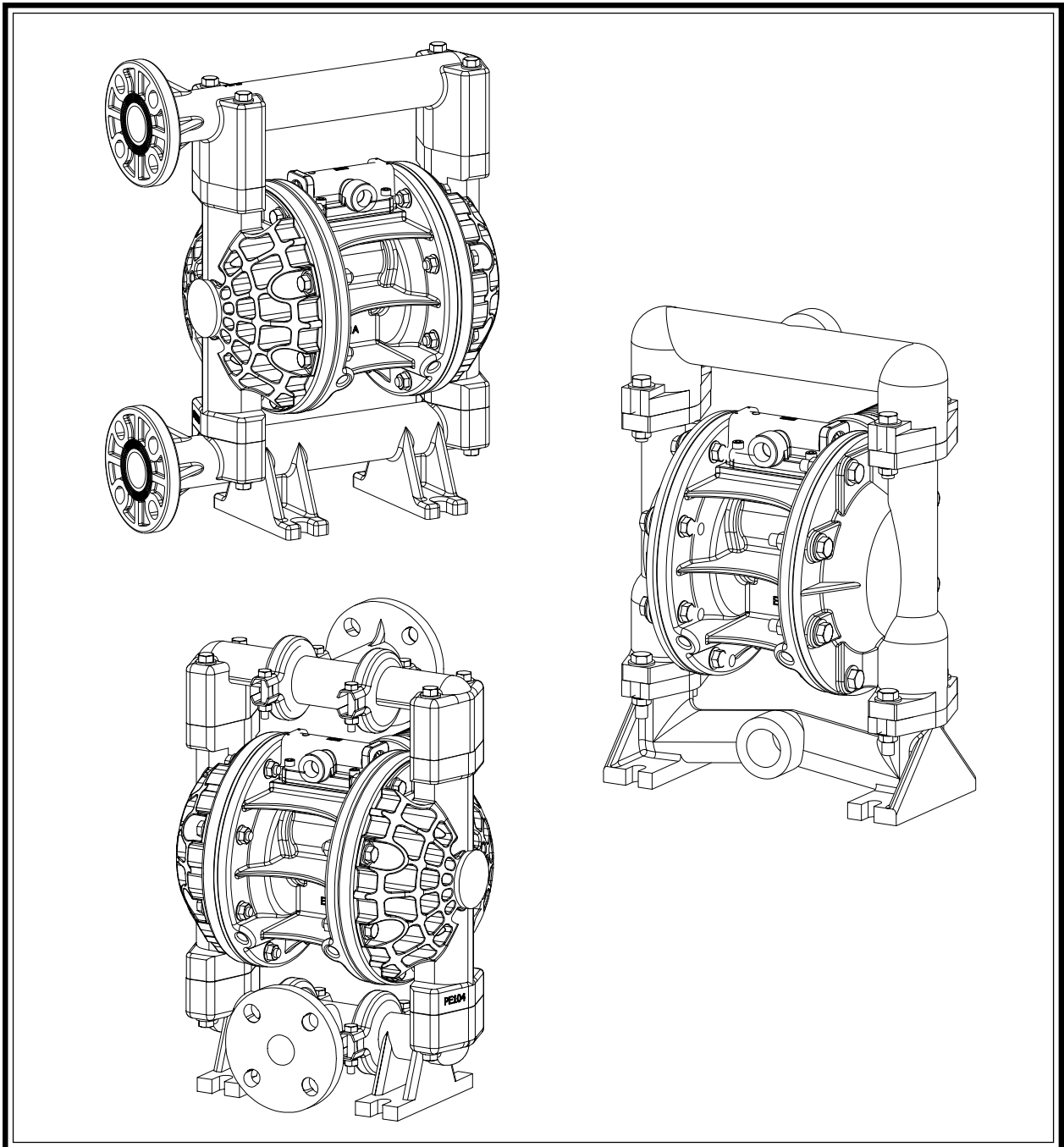

## OPERATING INSTRUCTIONS



Revised 01/03

1" Elima-Matic® Bolted Pump

**Characteristics**

Adjustable Flow Rate

Rugged Diaphragms.....0 to 8.5 m<sup>3</sup>/hr (0-37 gpm)  
 Teflon Diaphragms.....0 to 6.8 m<sup>3</sup>/hr (0-30 gpm)

Pump Connections

Suction.....1" 150# ANSI/ DIN #25 Flange  
 Discharge.....1" 150# ANSI/ DIN #25 Flange  
 Air Inlet.....0.375" NPTF  
 Air Exhaust.....0.5" NPTF

Suction Lift (Dry)

Rugged Diaphragms.....4.57 m (15 feet)  
 Teflon Diaphragms.....3.05 m (10 feet)

Maximum Particle Size.....3.17 mm Diameter  
 (0.125" diameter)

Shipping Weight

Polypropylene.....9.30 kg (20.5 lbs)  
 Kynar.....9.75 kg (21.5 lbs)  
 Stainless Steel & Hastelloy.....17.5 kg (38.5 lbs)  
 Aluminum.....12.5 kg (27.5 lbs)

**WARNING**

Air Operated Diaphragm Pumps may generate fluid pressures equal to the air supply pressure.

**DO NOT** exceed the recommended air supply pressure of 689 kPa (100 psi) for 1" Plastic Bolted pumps / Metallic Pumps 862 kPa (125 psi)

Hytrel®, Nordel®, Teflon®, and Viton®, are registered trademarks of DuPont.

Elima-Matic®, Versa-Tuff™, and Versa-Dome® are trademarks of Versa-Matic Tool, Inc.

**E1 Bolted Pump Specifications**

End Ported Dimensions

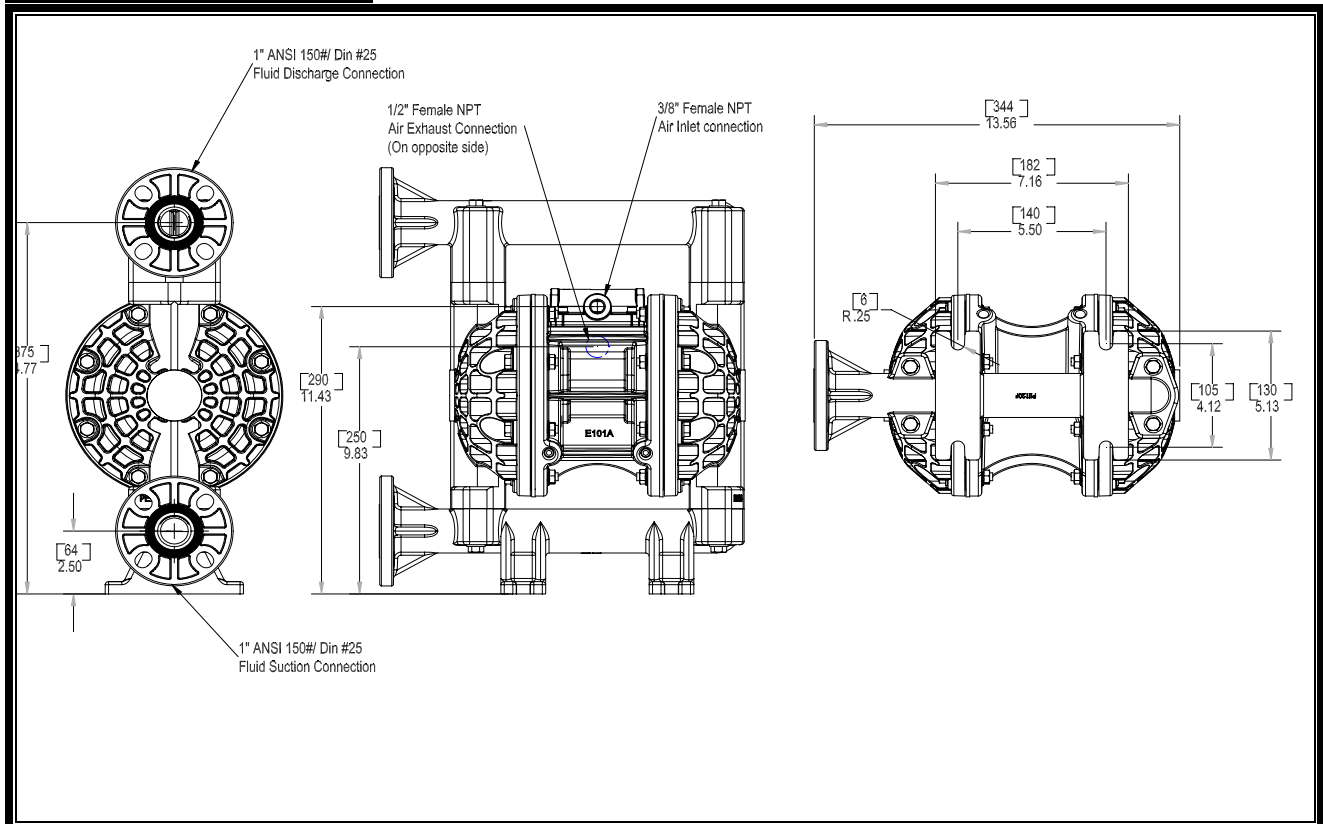

## Center Ported Dimensions

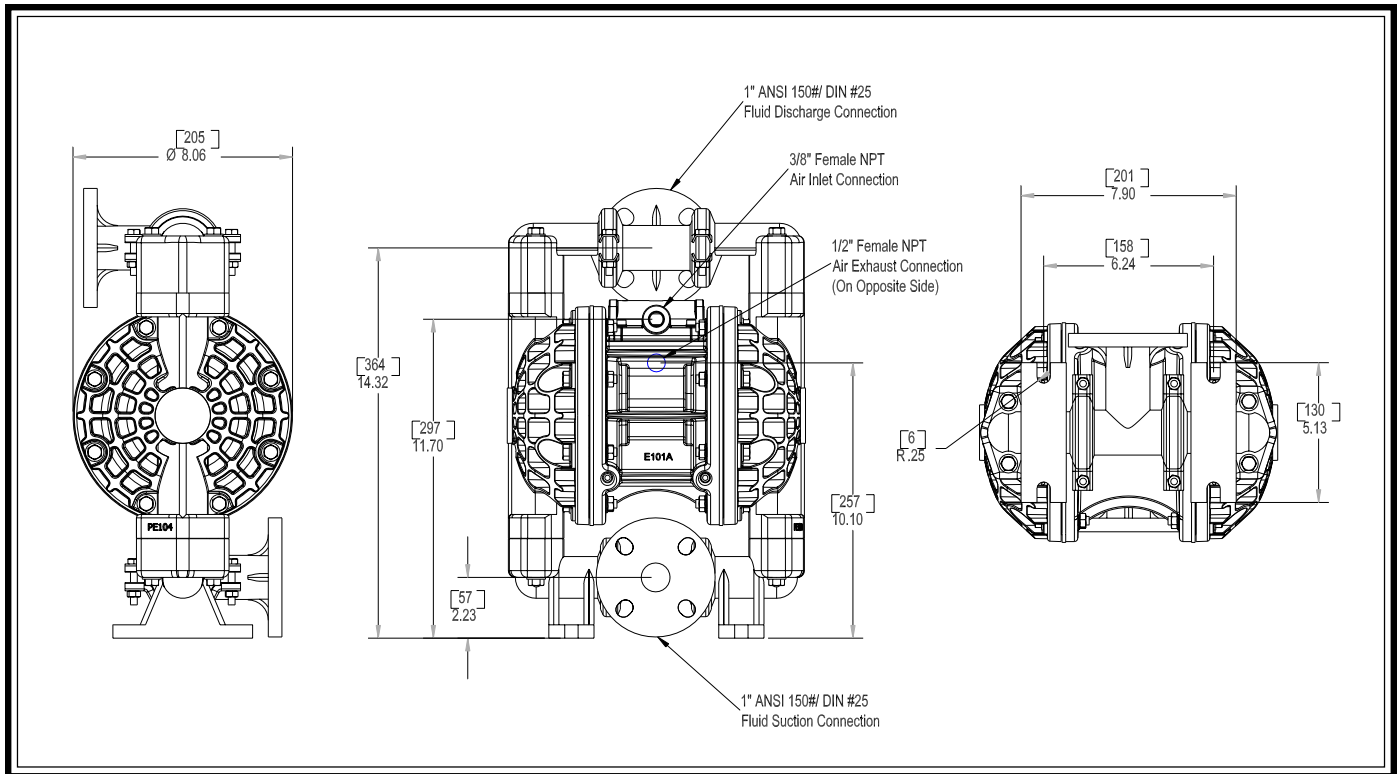

## Metallic Dimensions

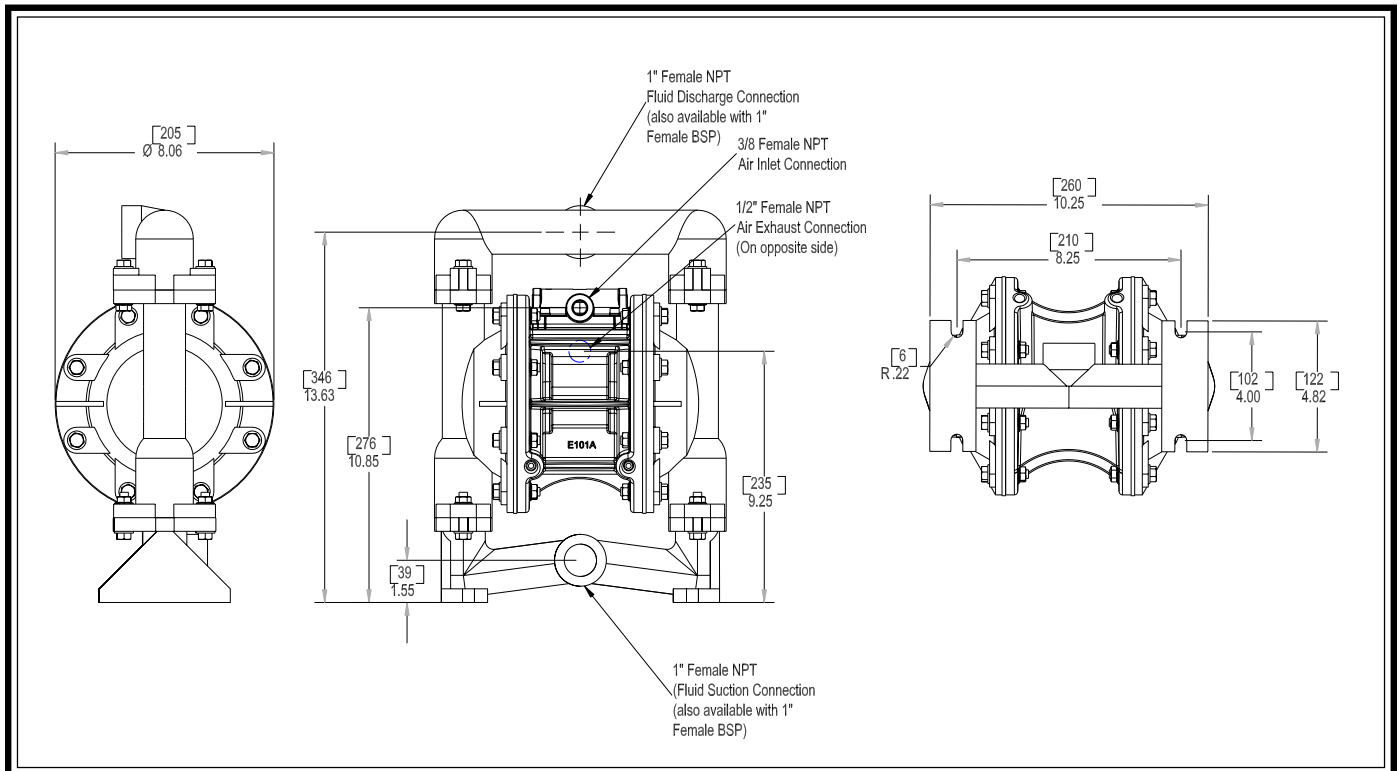

# E1 Bolted Pump Performance English Units1

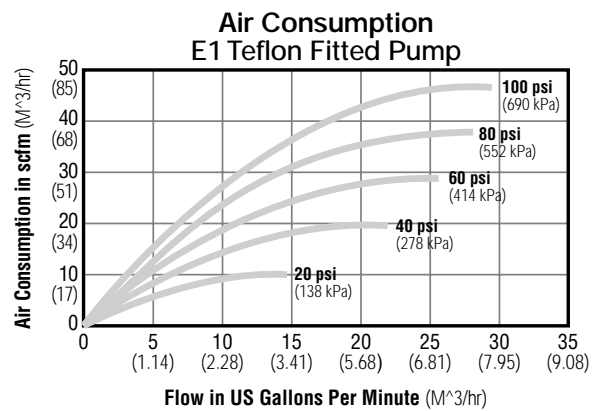
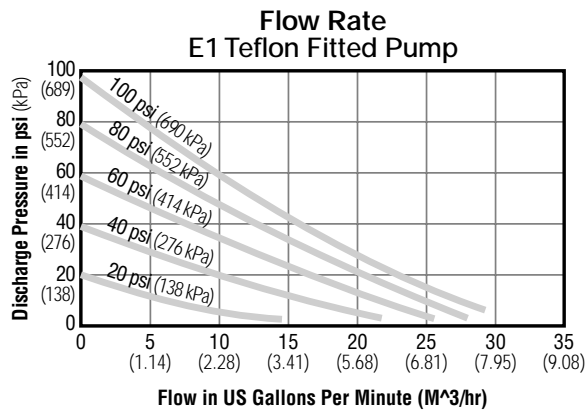
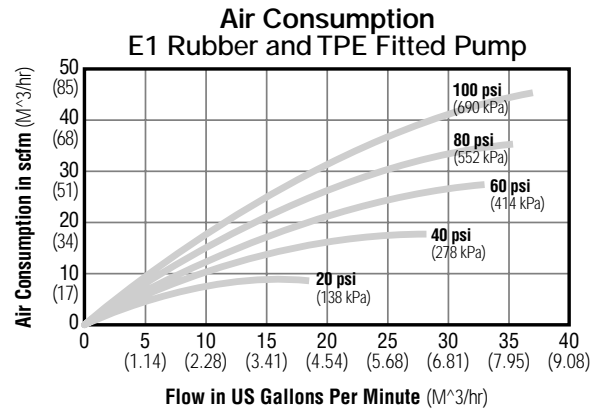
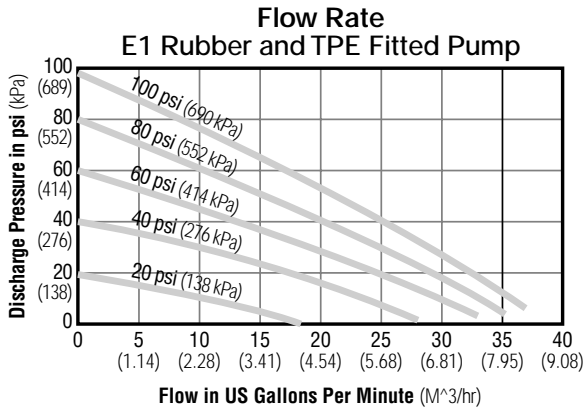

## How To Read Pump Performance Curves

To find the air inlet pressure and air volume necessary to operate a pump at a desired flow rate and head pressure you need to first go to the flow chart on the left. Find the desired flow horizontally on the chart and move vertically until you intersect with the system discharge pressure. This point represents the necessary air supply pressure. Next, go to the corresponding chart on the right. Find the desired flow horizontally across the bottom of the chart and move vertically until you cross the necessary air supply pressure. Finally, move horizontally to the left to find the required air supply volume.

Example: To obtain (4.54 M<sup>3</sup>/hr) 20 gpm of flow with (276 kPa) 40 psi of discharge pressure with a rubber fitted plastic bolted pump, you will need (552 kPa)80 psi of air inlet pressure and (44 M<sup>3</sup>/hr) 26 scfm air consumption.

## **Installation**

This pump comes with a footed base for easy mounting in permanent installations. The pump should be mounted in a vertical position. In permanent installations, the pump should be attached to plant piping using a flexible coupling on both the intake and discharge connections to reduce vibration to the pump and piping. To further reduce vibration, a surge suppressor next to the pump may be used.

Suction pipe size should be at least 1 inch in diameter or even larger if highly viscous fluid is to be pumped. If suction hose is used, it must be of a non-collapsible reinforced type. Discharge piping should be at least 1 inch in diameter. It is critical, especially on the suction side of the pump, that all fittings and connections are airtight or pumping efficiency will be reduced and priming will be difficult.

The air supply line should be at least 3/8 inch in diameter. Make certain the supply line and compressor are capable of supplying the required pressure and volume of air needed to operate the pump at the desired flow rate. The quality of the compressed air source should be considered. Air that is contaminated with moisture and dirt may result in erratic pump performance and increased maintenance cost as well as frequent process "down time" when the pump fails to operate properly.

## **Pump Operation**

The pump is powered by compressed air. Compressed air is directed to the pump air chamber by the main air valve. The compressed air is separated from the fluid by a membrane called a diaphragm. The diaphragm in turn applies pressure on the fluid and forces it out of the pump discharge. While this is occurring, the opposite air chamber is depressurized and exhausted to atmosphere and fluid is drawn into the pump suction. The cycle again repeats, thus creating a constant reciprocating action, which maintains flow through the pump. The flow is always in through the bottom suction connection and out through the top discharge connection. Since the air pressure acts directly on the diaphragms, the pressure applied to the fluid roughly approximates the air supply pressure supplied to the main valve.

## **Troubleshooting**

### **The pump will not run, or runs slowly:**

1. Examine the air inlet screen for debris.
2. Check for a sticking air valve. Remove the air valve from the pump and flush with solvent to remove dirt and/or debris. Check the spool and sleeve for nicks and scratches. If the spool is shiny instead of dull black, the spool and sleeve may be worn out and may need to be replaced. Clean all ports and airways and replace worn out gaskets and o-rings.
3. Check pilot shaft and main shaft for scoring and scratches; replace if needed. Replace the pilot shaft and main shaft o-rings if they are worn, flat or torn.

### **The pump runs, but little or no material flows:**

1. Check for pump cavitation, slow the pump speed down to match the thickness of the material being pumped.
2. Look for sticking ball checks. If the material being pumped is not compatible with the ball material, the elastomer may swell. Replace the balls and seats with a compatible elastomer type.
3. Make sure all the suction line fittings and connections are tight.

### **Air bubbles in pump discharge:**

1. Look for a ruptured diaphragm.
2. Check for suction leaks in pump manifolds and piping.

### **Material comes out of the pump air exhaust:**

1. Inspect the diaphragm for rupture.
2. Check the tightness of the diaphragm plates to the pump shaft.

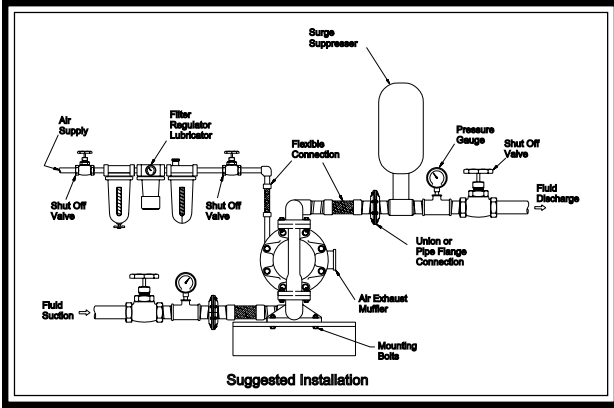

A typical installation showing all the components that are recommended in a system, including valves, pressure gauges, air regulators, filters, and surge suppressors.

In a submerged application, the air exhaust port of the pump must be ported above the fluid line. Be certain that the fluid being pumped is compatible with the materials on both the airside and the wetted side of the pump before the pump is submerged.

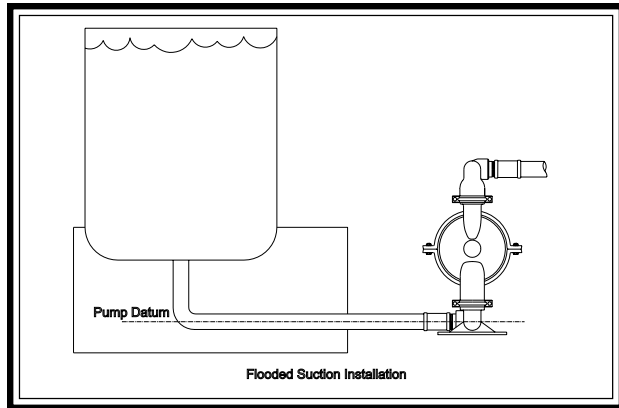
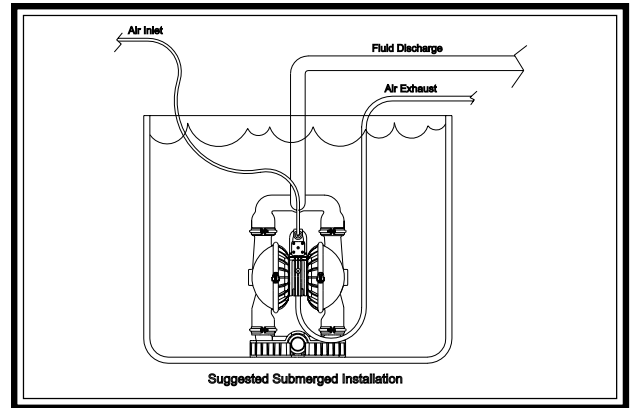

A flooded suction installation has the pump datum line below the fluid level. **IMPORTANT-** in flooded suction installations the pressure at the fluid inlet of the pump should never exceed 69 kPa (10 psi).

In suction lift installations the pump datum is above the fluid line. **IMPORTANT-** each pump has different lift capabilities. Be sure to verify the lift capability of a particular pump before installing it into a system.

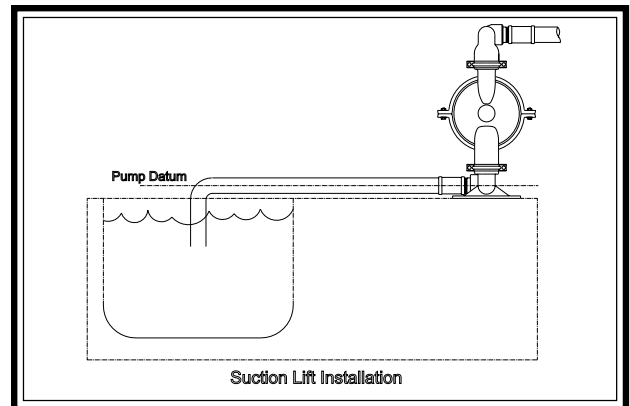

**Versa-Matic Pump Company**  
**Model E1, 1" Elima-Matic®**  
**Plastic Pump Parts List**

Pump Model Number			
With Rubber & XL Elastomers		With Teflon Elastomers	
E1PP Polypropylene	E1KP Kynar (PVDF)	E1PP5_5T Polypropylene TF/TF/TES	E1KP5_5T Kynar (PVDF) TF/TF/TES

Item	Description	Qty.	Applicable Part Number			
1	Valve Body	1			E100A	
2	Air Diverter	1			E100G	
3	Valve Insert	1			E100H	
4	Valve Spool	1			E100B	
5	U-Cup	2			P98-104A	
6	End Cap	2			E500D	
7	End Cap O-Ring	2			E500E	
8	Staple Retainer	2			E500F	
9	Air Valve Gasket	1			E100J	
10	SK Head Cap Screw	4			P24-208	
11	Center Section	1			E101A	
12	Main Shaft O-Ring	2			P50-403	
13	Muffler	1			VTM-4	
14	Pilot Spacer	5			P24-106P	
15	Pilot O-Ring	6			P24-107	
16	Shaft Retainer	2			E101B	
17	Self-Tapping Screw	4			E101C	
18	Pilot Shaft	1			P50-112	
19	Elastic Stop Nut	2			P24-108	
20	Shaft	1		P50-107		P50-108
21	Inner Diaphragm Plate	2		V181C		V181TI
22	Diaphragm (See Below For Material Selection)	2		V183xx-1		*V183TF-1 or V183TX (Teflon)
22a	Back-Up Diaphragm	2		N/R		V183TB (Hytrel)
23	Outer Diaphragm Plate	2	PE113	KE113	PV181TO	KV181TO
24	Discharge Manifold	1	PE120	KE120	PE120	KE120
25	Valve Ball (See Below For Material Selection)	4		V191xx		V191TF (Teflon)
26	Valve Seat	4	PE108	KE108	PE108	KE108
27	Valve Seat O-Ring (See Below For Material Selection)	4		V90xx		
28	Discharge Manifold Bolt	4		E120A		
29	Washer	24		SV189C		
30	Water Chamber	2	PE104	KE104	PE104	KE104
31	Water Chamber Bolt	16		SV187A		
32	Inlet Manifold	1	PE120F	KE120F	PE120F	KE120F
33	Inlet Manifold Bolt	4		SV187A		
34	Flange Nut	16		SV185B		
35	Manifold Tee	2	PV188	KV188	PV188	KV188
36	Discharge Elbow	2	PV186	KV186	PV186	KV186
37	Manifold Tee O-ring	4		V188TF (Teflon) or V188XL (XL)		
38	Small Clamp Assembly	4		SV189		
39	Manifold Bolt	4		SV186A		
40	Inlet Elbow	2	PV187	KV187	PV187	KV187

<b>Diaphragm Part Number &amp; Material</b> V183N-1, Neoprene V183BN-1, Buna-N V18ND1-, Nordel V183VT-1, Viton V183TPEXL-1, XL V183TPEFG Hytrel FDA *V183TX, one piece Teflon diaphragm (no back-up required)	<b>Valve Ball Part Number &amp; Material</b> V191N, Neoprene V191BN, Buna-N V191ND, Nordel V191VT, Viton V191TPEXL, XL V191TPEFG, Hytrel FDA	<b>Valve Seat O-Ring Numbers &amp; Material</b> V190TES, Teflon Encap, Silicone V90BN, Buna-N V90ND, Nordel V90VT, Viton
---	--	--

# 1" Plastic Bolted Pump Exploded View

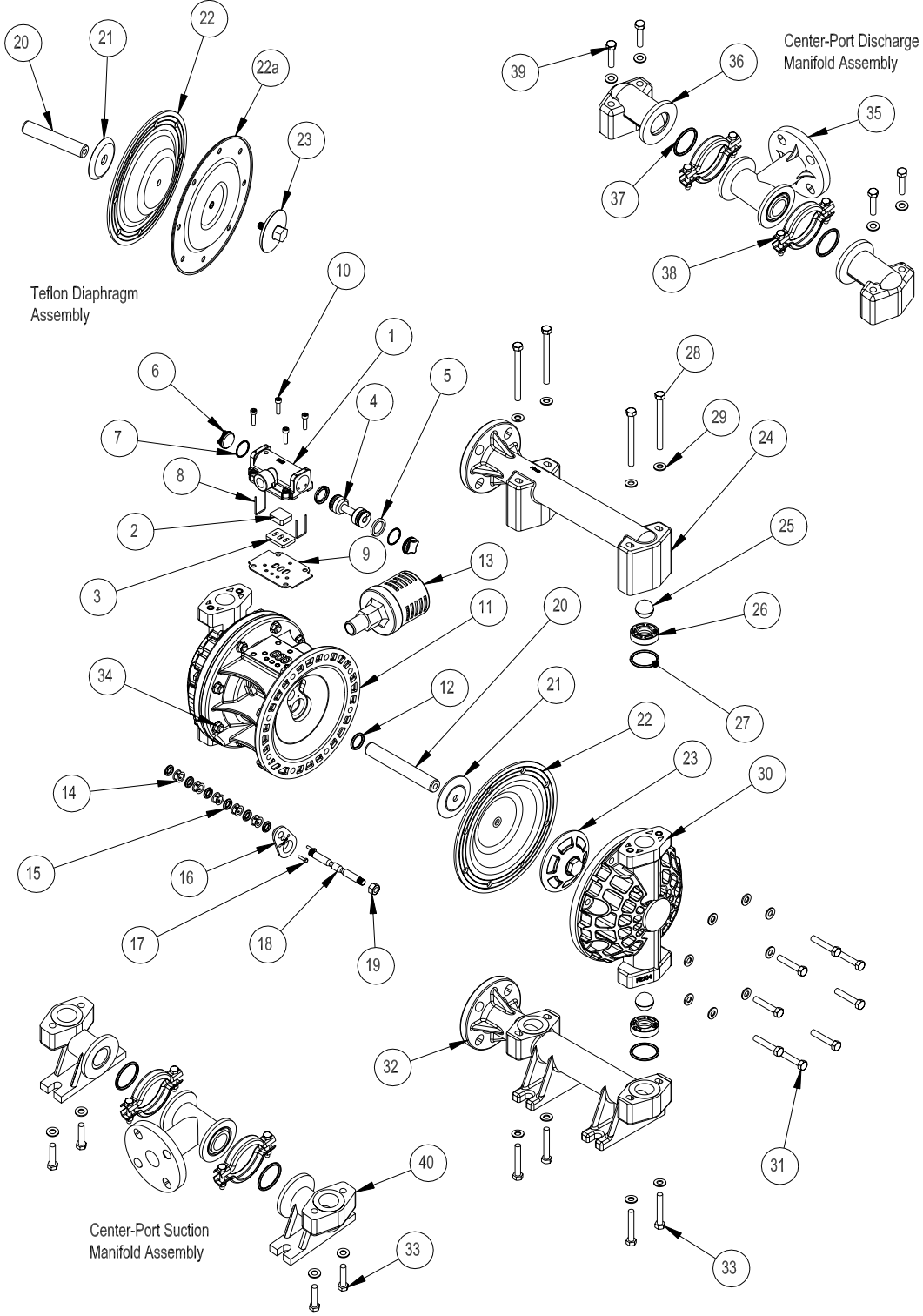



**Versa-Matic Pump Company**  
**Model E1, 1" Elima-Matic®**  
**Metallic Pump Parts List**

Pump Model Number				
With Rubber & XL Elastomers			With Teflon Elastomers	
E1AP Foot Mount Aluminum	E1SP Foot Mount Stainless Steel	E1AP Foot Mount Aluminum	E1SP Foot Mount Stainless Steel	E1HP Foot Mount Hastelloy C

Item	Description	Qty.	Applicable Part Number				
1	Valve Body	1	E100A				
2	Air Diverter	1	E100G				
3	Valve Insert	1	E100H				
4	Valve Spool	1	E100B				
5	U-Cup	2	P98-104A				
6	End Cap	2	E500D				
7	End Cap O-Ring	2	E500E				
8	Staple Retainer	2	E500F				
9	Air Valve Gasket	1	E100J				
10	Sk Head Cap Screw	4	P24-208				
11	Center Section	1	E101A				
12	Main Shaft O-Ring	2	P50-403				
13	Muffler	1	VTM-4				
14	Pilot Spacer	5	P24-106P				
15	Pilot O-Ring	6	P24-107				
16	Shaft Retainer	2	E101B				
17	Self-Tapping Screw	4	E101C				
18	Pilot Shaft	1	P50-112				
19	Elastic Stop Nut	2	P24-108				
20	Shaft	1	P50-107		P50-108		
21	Inner Diaphragm Plate	2	V181C		V181TI		
22	Diaphragm (See Below For Material Selection)	2	V183xx-1		*V183TF-1 or V183TX (Teflon)		
22a	Back-Up Diaphragm	2	NR		V183TB (Hytrell)		
23	Outer Diaphragm Plate (** Requires V181F Bolt)	2	V81B	SV181B**	SV181TO	SV181TO	HV181TO
24	Discharge Manifold	1	V86	SV186	V86	SV186	HV186
25	Valve Ball (See Below For Material Selection)	4	V191xx		V191TF (Teflon)		
26	Valve Seat	4	V90A	SV109	V90A	SV190	HV190
27	Valve Seat O-Ring (See Below for Material Selection)	4	V90xx		SV190TF (Teflon)		
28	Discharge Manifold Bolt	4	V187A	SV189D	V187A	SV189D	SV189D
29	Washer	24	V189C	SV189C	V189C	SV189C	SV189C
30	Water Chamber	2	V85	SV185	V85	SV185	HV185
31	Water Chamber Bolt	16	V189A	SV189D	V189A	SV189D	SV189D
32	Inlet Manifold	1	V87	SV187	V87	SV187	HV187
33	Inlet Manifold Bolt	4	V187A	SV189D	V187A	SV189D	SV189D
34	Flange Nut	16	V185B	SV185B	V185B	SV185B	SV185B

<b>Diaphragm Part Number &amp; Material</b> V183N-1, Neoprene V183BN-1, Buna-N V18ND1-, Nordel V183VT-1, Viton V183TPEXL-1, XL V183TPEFG Hytrell FDA *V183TX, one piece Teflon diaphragm (no back-up required)	<b>Valve Ball Part Number &amp; Material</b> V191N, Neoprene V191BN, Buna-N V191ND, Nordel V191VT, Viton V191TPEXL, XL V191TPEFG, Hytrell FDA	<b>Valve Seat O-Ring Numbers &amp; Material</b> V190TES, Teflon Encap, Silicone V90BN, Buna-N V90ND, Nordel V90VT, Viton
--	---	--

# 1" Metallic Bolted Pump Exploded View

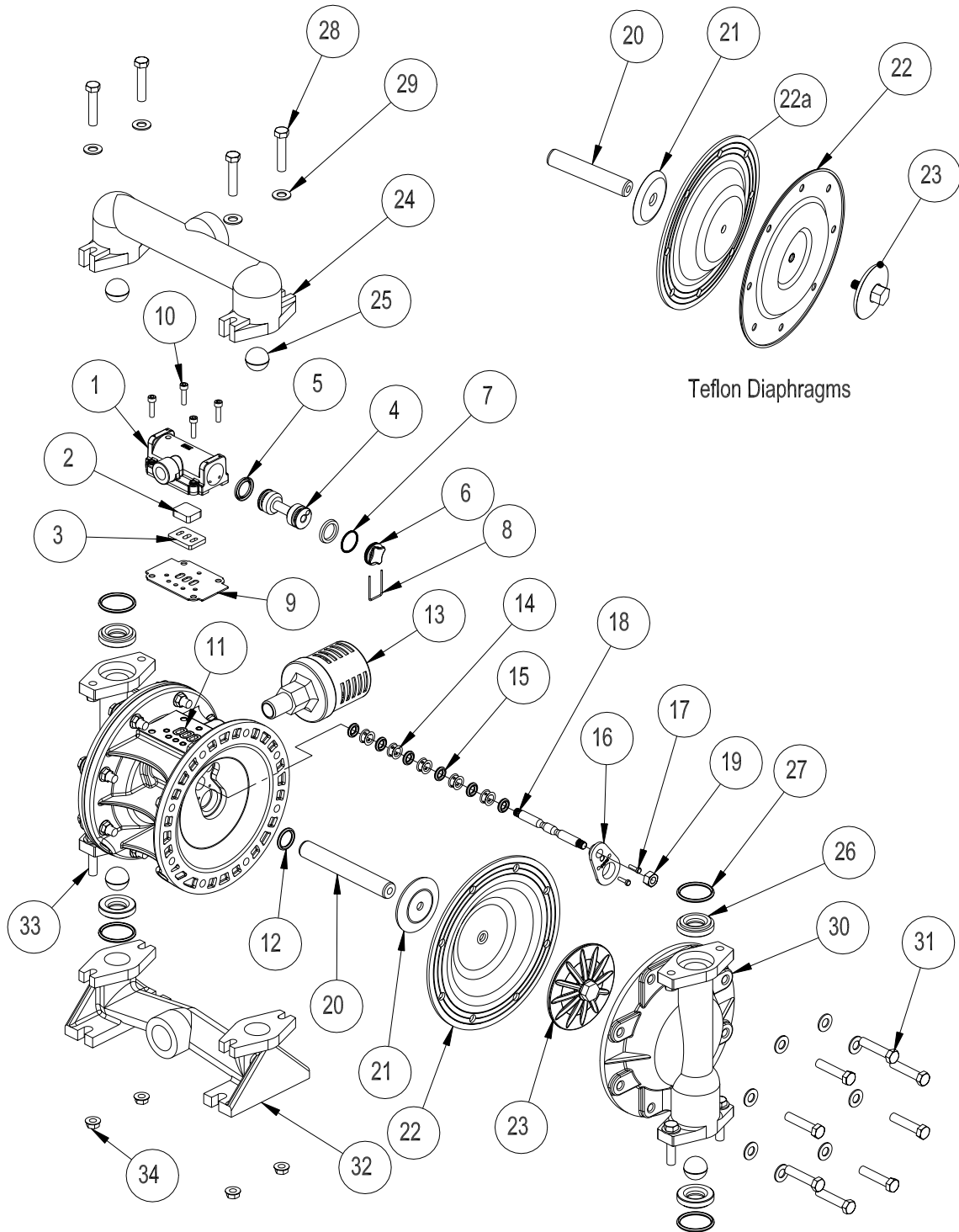

## Safety Warnings

This equipment should only be maintained by experienced professional technicians. Observe all safety warnings. Read all safety warnings and operating manuals before using or repairing this Air Operated Diaphragm Pump.

Any misuse of this equipment such as over-pressurization, modifying parts, pumping incompatible fluids, using worn or damaged parts, or using gasses other than compressed air to power the pump is not recommended. Any of these circumstances could result in splashing or spraying into the eyes or on skin, possible serious bodily injury, fire, explosion, or property damage.

### General Safety



ALWAYS wear safety glasses when using power tools to repair this equipment.



Wear proper ear protection when working or



standing near A.O.D. pumps. It is



recommended that an air exhaust muffler be used on this equipment at all times.

When the pumping system contains dangerous fluids, wear protective gloves, glasses, etc. when working on or around this equipment.

Always shut off the air supply and disconnect it from the pump before performing maintenance or repair on the pump.

Do NOT put your face or body near the pump air exhaust while the pump is operating.

Bleed all pressure from the discharge and suction lines before disconnecting the fluid suction or fluid discharge lines from the pump.

Before starting a pump, make certain that the discharge point of the piping system is clear and safe and all persons have been warned to stand clear.

Always make sure that safety shut off valves, regulators, pressure relief valves, gauges, etc. are working properly before starting the pump.

### Equipment Misuse Hazard

Do NOT operate a pump that is leaking, damaged, corroded, or otherwise unable to contain the internal fluid pressure.

Do NOT pump incompatible fluids through the pump. Consult your distributor or the factory if you are not sure of the compatibility of fluids with the castings and elastomers.

Never exceed the operating pressure recommended for the pump: 689 kPa (100 psi) for plastic models. Metallic pumps must not exceed 862 kPa (125 psi) operating pressure.

Do NOT submerge the pump in liquids that are incompatible with the wetted or non-wetted parts of the pump. If installing in a submerged location, extend the air exhaust port above the liquid surface with suitable pipe or hose. Route the exhaust line to a safe location away from people and install an air exhaust muffler.

A.O.D. pumps utilize an elastomeric membrane to separate the pumping liquid from the air supply. When this membrane ruptures, pumping fluid may be expelled from the air exhaust port. Always pipe the air exhaust port to a safe location or suitable container if dangerous or volatile liquids are being pumped.

Never allow the piping system to be supported by the pump manifolds or valve housing. The manifolds and valve housings are not designed to support any structural weight and failure of the pump may result. The use of flexible piping connections is highly recommended.

Do NOT exceed the recommended operating temperatures of the pump or pump failure may result.

## Temperature Limitations

Maximum temperature limitations are based on mechanical stress only. Certain chemicals will reduce the maximum safe operating temperature of A.O.D. pumps. Consult your dealer or Chemical Resistance Guide for compatibility and temperature limits.

Polypropylene: 0°C (32°F) to 79°C (175°F)  
Kynar: -12°C (10°F) to 107°C (225°F)

Do NOT exceed the maximum temperature limits of the elastomer type (diaphragms, balls, seats) that are used in the pump.

### Temperature Limits of Various Elastomer Types:

Neoprene: -18°C (0°F) to 93°C (200°F)  
Buna-N: -12°C (10°F) to 82°C (180°F)  
Nordel: -51°C (-60°F) to 138°C (280°F)  
Viton®: -40°C (-40°F) to 176°C (350°F)  
Teflon®: 4°C (40°F) to 105°C (220°F)  
Polyurethane: -12°C (10°F) to 77°C (170°F)  
XL TPE: -29°C (-20°F) to 149°C (300°F)  
FDA Hytrel®: -29°C (-20°F) to 104°C (220°F)

## Sound Level Ratings

1" Elimatic pumps (Model E1) have a decibel reading of 78 dB(A) when equipped with a factory installed air exhaust muffler.

The decibel readings are obtained with a Pacer Industries model SL-120, sound level indicator "A" scale. Readings are made at a distance of 1 meter from the pump and at a height of 1.6 meters above the floor. It is assumed that the pumps will be installed at floor level.

## Temperature Limitations



The diaphragm plates (sometimes referred to as piston plates) located inside the pump on either side of the main shaft move when air pressure is supplied to the pump. Therefore, never attempt to operate the pump with the liquid chambers removed. Moving parts inside the pump can pinch or seriously injure fingers or other body parts.

## Fire or Explosion Hazard

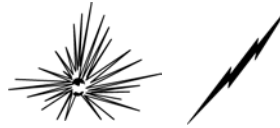

Static electricity can be created by the flow of fluid through the pump or by the reciprocating action of A.O.D. pumps. If the pump is not properly grounded, sparking may occur and the system may become hazardous. Sparks can ignite fumes or vapor and cause an explosion.

If you experience static sparking or even a slight shock while using the pump, do not continue to operate the pump until the pump is properly grounded.

### Proper Grounding

To ground metallic pumps, connect a ground wire to any accessible point of attachment such as a connecting bolt or the mounting base.

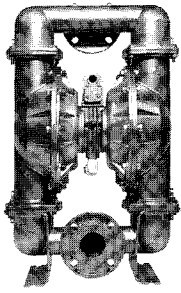

**ELIMA-MATIC®  
ANTI-STALLING PUMPS**

- ☐ Virtually eliminates pump stalling caused by air valve system freeze-ups
- ☐ Anti-stalling, non-icing, lubrication-free air valve system.
- ☐ Available in 1/2", 1", 1 1/4", 2" and 3" sizes
- ☐ Wide selection of materials of construction—including 1/2", 1" and 2" plastic models

**PLASTIC PUMPS FOR SOLVENTS AND CHEMICALS**

- ☐ Exceptional corrosion resistance
- ☐ Wide selection of materials of construction for wetted and non-wetted parts
- ☐ Leak free bolted construction
- ☐ Also available in 1/2", 1", 1 1/2" and 2" with the Elima-Matic anti-stalling air valve system

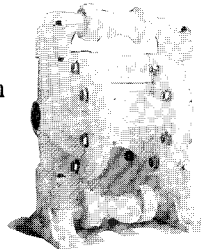

**Elima-Matic 2:1 High Pressure Pump**

- ☐ Cast in 150lbs ANSI/DIN flanges
- ☐ Constructed of 316 stainless steel
- ☐ Can create discharge pressure over 200 psi
- ☐ Leak-Free bolted design

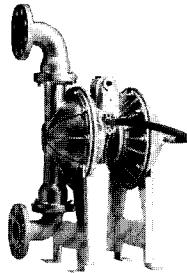

**VERSA-DOME® DIAPHRAGMS**

- ☐ The simple, smooth design eliminates complex angles allowing for 3 to 4 times the flex life of standard diaphragms.
- ☐ So flexible they can be installed and removed without the use of pry bars
- ☐ Has lower start up pressure than standard diaphragm.
- ☐ Available Neoprene, Buna-N, Hytrel, Nordel®, Viton® and XL.
- ☐ For use in Versa-Matic and Wilden 1/2", 2", 3" pumps.

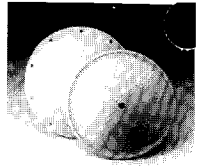

**VERSA-TUFF TEFLON DIAPHRAGMS**

- ☐ Single piece diaphragm combining the chemical resistance of Teflon with the flex life of rubber.\*
- ☐ Three times the burst strength of ordinary Teflon overlays
- ☐ More flexible and 100% bonded to the reinforced rubber backing
- ☐ Diaphragms can be placed into Wilden® M4 and M8 pumps

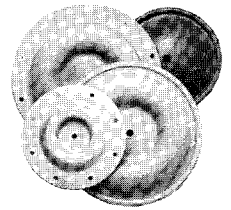

**GENUINE VERSA-MATIC REPLACEMENT PARTS AND RETRO FIT CENTER SECTIONS**

- ☐ Upgrade V-series and Wilden® M4, M8, and M15 pumps with an Elima-Matic retro fit center section
- ☐ For complete repair of Versa-Matic pumps and Wilden® M4, M8 and M15 metallic pumps
- ☐ Cost-saving elastomer kits for any Versa-Matic pump or Wilden® M1, M2, M4, M8 and M15 pumps
- ☐ Diaphragm and elastomer repair kits available in Buna-N, Neoprene, Nordel®, Teflon®, Viton®, Thermo Plastics Hytrel®, and XL

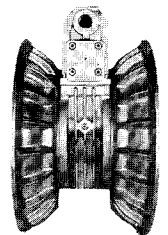

Your local authorized distributor:

**FOOD AND SANITARY PUMPS**

**SANITARY PUMPS**

- ☐ FDA approved for use with milk and milk products
- ☐ Constructed of 316 stainless steel
- ☐ Surface finish of 32 micro-inch or better
- ☐ Removable ball cages
- ☐ Easy clean Tri-clamp® connections

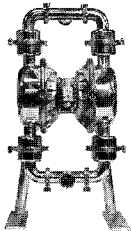

**FOOD PROCESSING PUMPS**

- ☐ Constructed of 316 stainless steel
- ☐ FDA approved
- ☐ Tri-clamp® connections
- ☐ Over-sized clamp wing nuts for disassembly

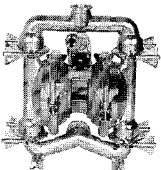

**VERSA-MATIC PUMP**

6017 Enterprise Drive  
Export, PA 15632-8969  
(724) 327-7867 • Fax: (724) 327-4300

[www.versamatic.com](http://www.versamatic.com)

\* Life cycle may vary according to extreme start-up conditions, chemicals and abrasive fluids. To prolong diaphragm life, Versa-Matic recommends a gradual increase in air supply on pump start-up.

Elima-Matic®, Versa-Dome®, Versa-Matic® and VR® are registered trademarks or trademarks of Versa-Matic Tool, Inc. Some Versa-Matic Tool, Inc. products are subject to patent pending applications and issued patents, Elima-Matic U.S. Patent No. 5,326,234. Hytrel®, Nordel®, Teflon® and Viton® are registered trademarks of DuPont. Tri-Clamp® is a registered Trademark of the Tri-Clamp, Inc. Wilden® is a registered Trademark of Wilden Pump and Engineering Co.

