

E1 1" Plastic Bolted Pumps: Standard Porting Specifications and Performance

SPECIFICATIONS

E1

FLOW RATE (Adjustable) 0-35 gpm (132 lpm)
PORT SIZE
 Inlet and Outlet..... 1.0" ANSI/DIN Flanged
AIR INLET 0.375" NPT
AIR EXHAUST 0.50" NPT
SUCTION LIFT 15' Dry/25' Wet (4.57m/7.62m)
 Teflon®..... 10' Dry/20' Wet (3.05m/6.10m)
MAX. PARTICLE SIZE (Dia.) 0.125"(3.17mm)
SHIPPING WEIGHTS
 Polypropylene 24 lbs (10.9 kg)
 Kynar® 24 lbs (10.9 kg)

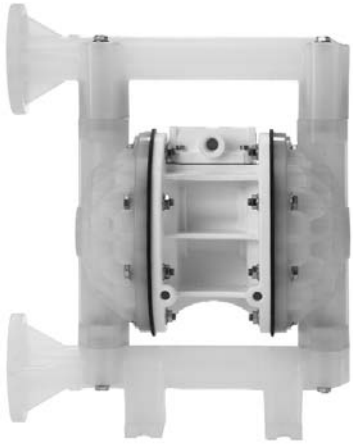

PERFORMANCE

Determined by actual flow meter tests.

E1

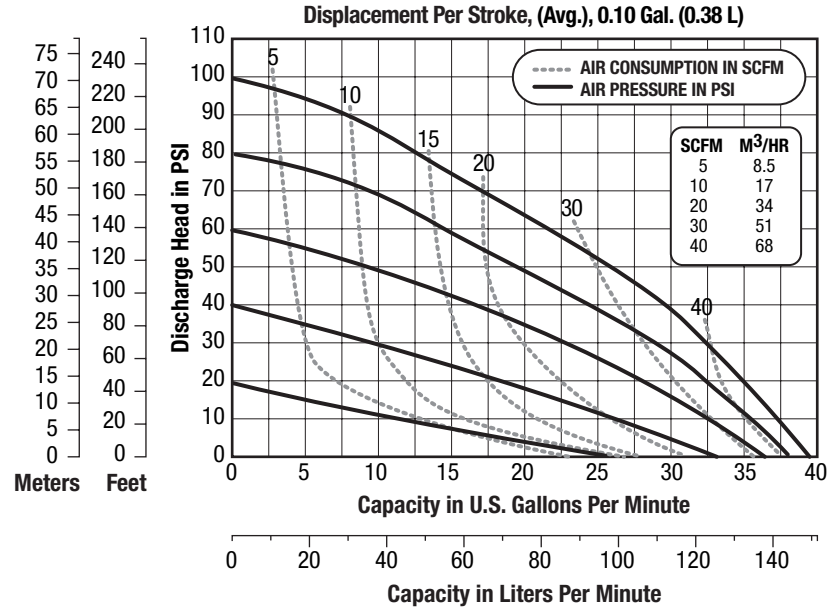

NOTE: For E1 pumps fitted with Teflon® diaphragms, reduce water discharge figures by 20%. Suction lift is reduced to 10' (3.05m) dry and 20' (6.10m) wet.

CAUTION: Do not exceed 100 psig (6.9 bars) air supply or liquid pressure.

OPTIONS: Center Port and Split Manifolds Available.

DIMENSIONS

Consult factory for certified drawings.

E1

