

**VERSA-MATIC
PUMP**

IDEX
IDEX CORPORATION

Member of
Hydraulic
INSTITUTE

PUMPTM
VERSA-MATIC® PUMP
Operating Instructions

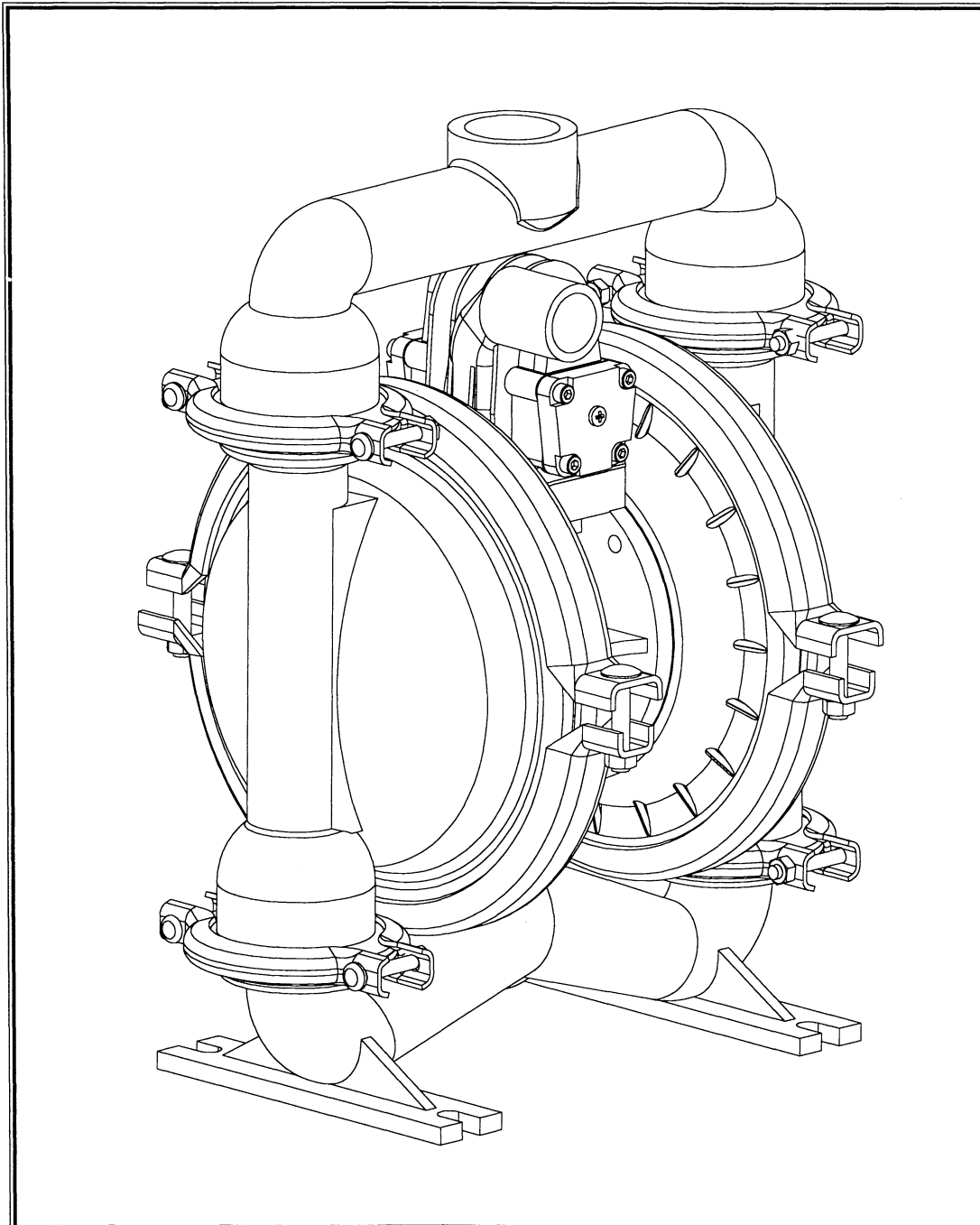
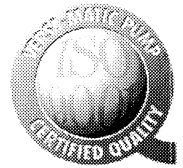

**Model E4
Elima-
Matic
Pump**

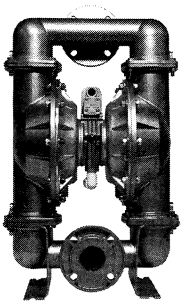

ELIMA-MATIC® ANTI-STALLING PUMPS

- Virtually eliminates pump stalling caused by air valve system freeze-ups
- Anti-stalling, non-icing, lubrication-free air valve system.
- Available in 1/2", 1", 1 1/4", 2" and 3" sizes
- Wide selection of materials of construction—including 1/2", 1" and 2" plastic models

PLASTIC PUMPS FOR SOLVENTS AND CHEMICALS

- Exceptional corrosion resistance
- Wide selection of materials of construction for wetted and non-wetted parts
- Leak free bolted construction
- Also available in 1/2", 1" and 2" with the Elima-Matic anti-stalling air valve system

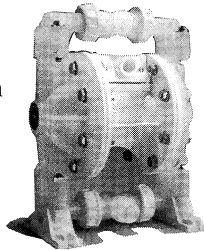

Elima-Matic 2:1 High Pressure Pump

- Cast in 150lbs ANSI/DIN flanges
- Constructed of 316 stainless steel
- Can create discharge pressure over 200 psi
- Leak-Free bolted design

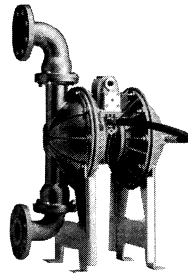

FOOD AND SANITARY PUMPS

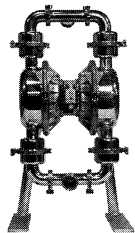

SANITARY PUMPS

- FDA approved for use milk and milk products
- Constructed of 316 stainless steel
- Surface finish of 32 micro-inch or better
- Removable ball cages
- Easy clean Tri-clamp® connections

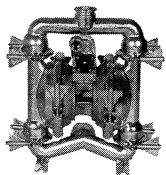

FOOD PROCESSING PUMPS

- Constructed of 316 stainless steel
- FDA approved
- Tri-clamp® connections
- Over-sized clamp wing nuts for disassembly

VERSA-MATIC PUMP

6017 Enterprise Drive
Export, PA 15632-8969
(724) 327-7867 • Fax: (724) 327-4300

www.versamatic.com

** Life cycle may vary according to extreme start-up conditions, chemicals and abrasive fluids. To prolong diaphragm life, Versa-Matic recommends a gradual increase in air supply on pump start-up.*

Elima-Matic®, Versa-Dome®, Versa-Matic® and VR ' are registered trademarks or trademarks of Versa-Matic Tool, Inc. Some Versa-Matic Tool, Inc. products are subject to patent pending applications and issued patents. Elima-Matic U.S. Patent No. 5,326,234. Hytrel®, Nordel®, Teflon® and Viton® are registered trademarks of DuPont. Tri-Clamp® is a registered Trademark of the Tri-Clamp, Inc. Wilden® is a registered Trademark of Wilden Pump and Engineering Co.

VERSA-DOME® DIAPHRAGMS

- The simple, smooth design eliminates complex angles allowing for 3 to 4 times the flex life of standard diaphragms.
- So flexible they can be installed and removed without the use of pry bars
- Has lower start up pressure than standard diaphragm.
- Available Neoprene, Buna-N, Hytrel, Nordel®, Viton® and XL.
- For use in Versa-Matic and Wilden 1/2", 2", 3" pumps.

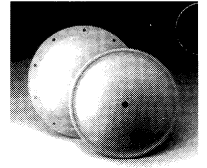

VERSA-TUFF TEFLON DIAPHRAGMS

- Single piece diaphragm combining the chemical resistance of Teflon with the flex life of rubber.*
- Three times the burst strength of ordinary Teflon overlays
- More flexible and 100% bonded to the reinforced rubber backing
- Diaphragms can be placed into Wilden® M4 and M8 pumps

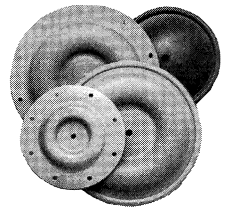

GENUINE VERSA-MATIC REPLACEMENT PARTS AND RETRO FIT CENTER SECTIONS

- Upgrade V-series and Wilden® M4, M8, and M15 pumps with an Elima-Matic retro fit center section
- For complete repair of Versa-Matic pumps and Wilden® M4, M8 and M15 metallic pumps
- Cost-saving elastomer kits for any Versa-Matic pump or Wilden® M1, M2, M4, M8 and M15 pumps
- Diaphragm and elastomer repair kits available in Buna-N, Neoprene, Nordel®, Teflon®, Viton®, Thermo Plastics Hytrel®, and XL

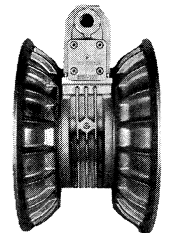

Your local authorized distributor:

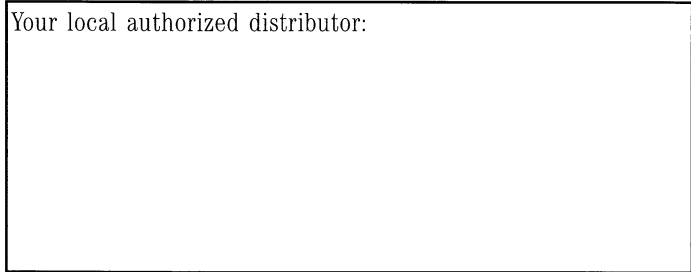

Specifications and Performance

Volumes indicated on charts were determined by flow meter tests.

Versa-Matic Model E4

Flow Rate Adjustable to.....0-70 gpm
(0-265 lpm)

Port Size:

Inlet.....1.5" NPT (BSP)
Discharge.....1.25" NPT (BSP)
Air Inlet.....1/2" NPT
Air Exhaust.....3/4" NPT
Suction Lift.....15' (4.57m) Dry/
25' (7.62m) Wet
Teflon.....10' (3.05m) Dry/
20' (6.09m) Wet

Max. Particle Size

(Diameter)..... 0.1875" (4.76mm)

Shipping Weights

Aluminum.....41 lbs (18.61 kg)
Cast Iron, Hastelloy C,
Stainless.....57 lbs (25.87 kg)

Caution: Do not exceed 125
psig (8.5 bar) air supply or
liquid pressure.

Teflon® is a registered tradename of E.I.
DuPont

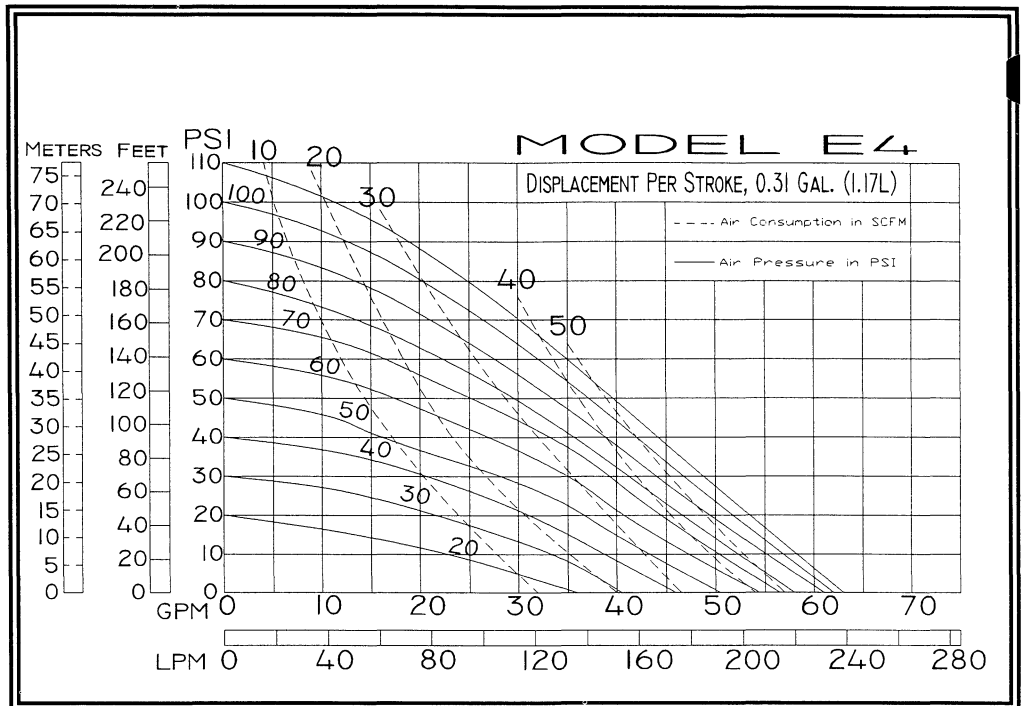

Note:

For E4 pumps fitted with Tef-Matic™ diaphragms, reduce water discharge figures by 20%.

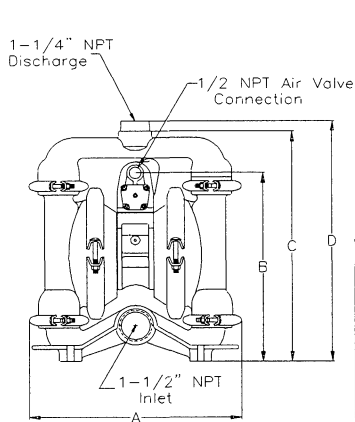

NOTE: Cast-in-place Nipple, Aluminum Pump Only. Female Threaded on others.

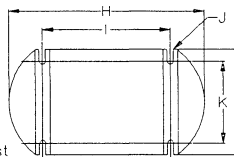
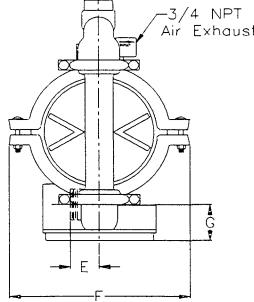

SCREEN BASE
(ALUMINUM PUMPS ONLY)

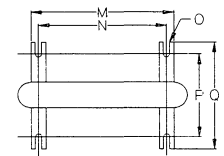

FOOTED BASE

DIMENSIONS MODEL E4

ITEM	INCHES	METRIC MM
A	14.25	361
B	13.5	343
C	16.75*	425*
D	18**	457**
E	2	51
F	11.5	292
G	2.37	60
H	13.25	337
I	8.75	222
J	0.437	11
K	WIDE SLOT	WIDE SLOT
L	6	152
M	7.625	194
N	10	254
O	8.75	222
P	0.437	11
Q	WIDE SLOT	WIDE SLOT
	6	152
	7	178

* Cast Iron, Hastelloy C and Stainless Steel Pumps
** Aluminum Pumps



6017 Enterprise Drive
Export, PA 15632
Phone (724) 327-7867
Fax (724) 327-4300

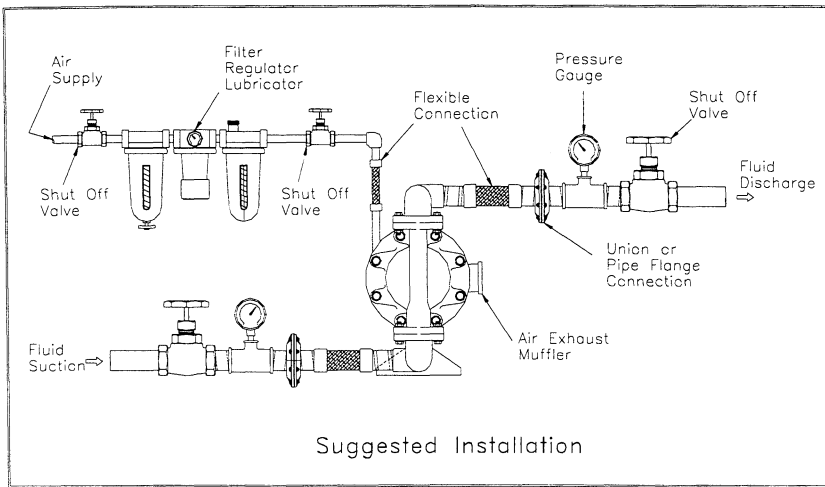

Caution
Do Not Exceed
125 psig air supply
pressure

Installation

The E4 pump comes with a footed base for easy mounting in permanent installations. The pump should be mounted in a vertical position. In permanent installations, the pump should be attached to plant piping using a flexible coupling on both the intake and discharge connections to reduce vibration to the pump and piping. To further reduce vibration, a surge suppresser next to the pump may be used.

Suction pipe size should be at least 1 ½ inches in diameter or even larger if highly viscous fluid is to be pumped. If suction hose is used, it must be of a non-collapsible reinforced type. Discharge piping should be of at least 1 ¼ inches. It is critical, especially on the suction side of the pump, that all fittings and connections are air tight or pumping efficiency will be reduced and priming will be difficult.

The air supply line should be at least ½ inch diameter. Make certain the supplying line and compressor are capable of supplying the required pressure and volume of air to operate the pump at the desired flow rate. The quality of the compressed air source should be considered. Air that is contaminated with moisture and dirt may result in erratic pump performance and increased maintenance cost as well as frequent process “down time” when the pump fails to operate properly.

Pump Operation

The pump is powered by compressed air. Compressed air is directed to the pump air chamber by the main air valve. The compressed air is separated from the fluid by a membrane called a diaphragm. The diaphragm in turn applies pressure on the fluid and forces it out of the pump discharge. While this is occurring, the opposite air chamber is de-pressurized and exhausted to atmosphere and fluid is drawn into the pump suction. The cycle again repeats, thus creating a constant reciprocating action which maintains flow through the pump. The flow is always in through the bottom suction connection and out through the top discharge connection. Since the air pressure acts directly on the diaphragms, the pressure applied to the fluid roughly approximates the air supply pressure supplied to the main air valve.

Trouble Shooting

The pump will not run, or runs slowly:

1. Examine the air inlet screen for dirt.
2. Check for a sticking air valve. Remove air valve from the pump and flush with solvent to remove dirt and debris. Check the Spool and Sleeve for nicks and scratches. If the spool is shiny instead of dull black, the spool and sleeve may be worn out and may need to be replaced. Clean all ports and airways and replace worn out gaskets and O-Rings.
3. Check Pilot Shaft and Main Shaft for scoring and scratches; replace if needed. Replace the Pilot Shaft and Main Shaft O-Rings if they are worn, flat or torn.

The pump runs, but little or no material flows:

1. Check for pump cavitation, slow the pump speed down to match the thickness of the material being pumped.
2. Look for sticking ball checks. If the material being pumped is not compatible with the ball material, the elastomer may swell. Replace the balls and seats with a compatible elastomer type.
3. Make sure all the suction line fittings and connections are air tight.

Air bubbles in pump discharge:

1. Look for ruptured diaphragm.
2. Check for suction leaks in pump manifolds and piping.

Material comes out of the pump air exhaust:

1. Inspect the diaphragm for rupture.
2. Check the tightness of the diaphragm plates to the pump shaft.

Safety Warnings

This equipment should only be used by experienced professional mechanics. Observe all safety warnings. Read all safety warnings and operating manuals before using or repairing this Air Operated Diaphragm Pump. (A.O.D. pump)

General Safety

This equipment may generate fluid pressures equal to the air supply pressure. Therefore DO NOT exceed the recommended air supply pressure. 100 psi (6.8 bar) for plastic pumps, 125 psi (8.5 bar) for metallic pumps.

ALWAYS wear safety glasses when using power tools to repair this equipment.

When the pumping system contains dangerous fluids wear protective gloves, glasses etc. when working on or around this equipment.

ALWAYS shut off the air supply and disconnect it from the pump before performing maintenance or repair to the pump.

Do Not put your face or body near the pump air exhaust while the pump is operating.

Bleed all pressure from discharge and suction lines before disconnecting the fluid suction or fluid discharge lines from the pump.

DO NOT operate a pump that is leaking, damaged, corroded or otherwise unable to contain the internal fluid pressure.

ALWAYS make sure safety shut off valves, regulators, pressure relief valves, gauges etc. are working properly before starting the pump.

DO NOT pump incompatible fluids through the pump. Consult your distributor or the factory if you are not sure of compatibility of fluids with the castings and elastomers.

Versa-Matic pumps are designed to operate on compressed air. Other compressed gases have not been tested and may be unsafe to use in A.O.D. pumps.

Before starting a pump make certain the discharge point of the piping system is clear and safe and all person have been warned to stand clear.

Equipment Misuse Hazard

General Safety

Any misuse of this equipment such as over pressurization, modifying parts, pumping incompatible chemicals and fluids, using worn or damaged parts or using gasses other than compressed air to power the pump is not recommended. Any of these circumstance could result in splashing or spraying into the eyes, skin or possible serious bodily injury, fire, explosion or property damage.

Over pressurization

Never exceed the operating pressure recommended for the model pump being used.

Noise

Wear Proper Ear protection when working or standing near A.O.D. pumps. IT IS recommended that a Air Exhaust Muffler is used on this equipment at all time.

Installation Hazards

Do not submerge the pump in liquids that are incompatible with the wetted or non-wetted parts of the pump. If installing in a submerged location extend the air exhaust port above the liquid surface with suitable pipe or hose.

Route exhaust line to safe location away from people and install a Air Exhaust Muffler.

Pump Diaphragm Failure

A.O.D. pumps utilize a elastomeric membrane to separate the pumping liquid from the air supply. When this membrane ruptures pumping fluid may be expelled from the air exhaust port. Always pipe the air exhaust port to a safe location or suitable container if dangerous or volatile liquids are being pumped.

Installation

Never allow the piping system to be supported by the pump manifolds or valve housing. The manifolds and valve housings are not designed to support any structural weight and failure of the pump may result. The use of flexible piping connections is highly recommended.

Temperature limits

Do not exceed the recommended operating temperatures of the pump or pump failure may result.

Moving Parts Hazard

The diaphragm plates (sometimes referred to as piston plates) located inside the pump on either side of the main shaft move when air pressure is supplied to the pump. Therefore, Never attempt to operate the pump with the liquid chambers removed. Moving parts inside the pump can pinch or seriously injure your fingers or other body parts.

Fire or Explosion Hazard

Static electricity can be created by the flow of fluid through the pump or by the reciprocating action of A.O.D. pumps. If the pump is not properly grounded, sparking may occur, and the system may become hazardous. Sparks can ignite fumes or vapor and cause an explosion.

If you experience static sparking or even a slight shock when using the pump do not continue to operate the pump until the pump is properly grounded.

Proper Grounding

Pump, Valves, Discharge and supply lines as well as containers must be grounded. These items must be grounded when handling flammable fluids and when static electricity discharge is a hazard.

1. To ground plastic pumps connect a ground wire to all metallic clamps as well as the air valve body & piston assembly. The ground wire should be connected to a suitable ground location. (figure 1)
2. To ground metallic pumps, connect a ground wire to any accessible point of attachment such as clamp band bolt or mounting base.

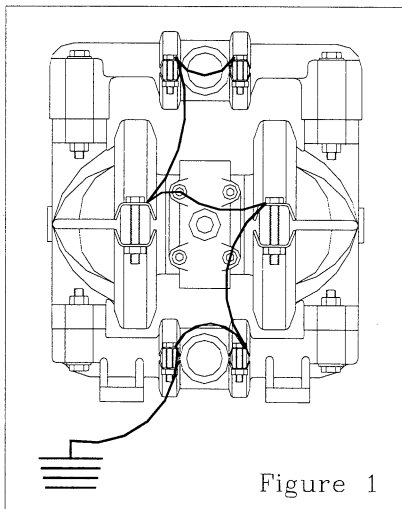

Figure 1

Sound Level Ratings, dB(A)

The following table lists the sound level ratings of Versa-Matic Pumps equipped with factory installed Air Exhaust Mufflers. The readings were obtained with a Pacer Industries model SL-120, sound level indicator "A" scale. Readings were made at a distance of 1 meter from the pump and a height of 1.6 meters above the floor. It is assumed the pumps will be installed at floor level.

Pump Series	dB(A) reading
E5, 1/2" pump	71.7 dB(A)
E1, 1" pump	76.5 dB(A)
V4, 1-1/4" pump	76.5 dB(A)
V2, 2" pump	74.3 dB(A)
V3, 3" pump	67.1 dB(A)
E2, 2" pump	74.3 dB(A)
E3, 3" pump	67.1 dB(A)
E4, 1-1/4" pump	76.5 dB(A)

Temperature Limitations

Maximum Temperature limitation are based on mechanical stress only. Certain chemicals will reduce the maximum safe operating temperatures of A.O.D pumps. Consult your dealer or Chemical Resistance guide for compatibility and temperature limits.

Metallic Pumps

Metallic pumps can operate past 212°F (100°C). However if you are operating above these limits, consult the factory for assistance.*

Plastic Pumps

Plastic pumps can operate within the following limits:*

Polypropylene:	32°(0°C) to 175°F(79°C)
PVDF (Kynar):	10°F(-12°C) to 225°F(107°C)
Teflon PFA:	-20°F(-29°C) to 200°F(93°C)

*Do not exceed the maximum temperature limits of the elastomer type (diaphragms, balls, seats) that is used in your pump.

Temperature limits of various elastomer types

Neoprene:	0°F(-18°C) to 200°F(93°C)
Buna-N:	10°F(-12°C) to 180°F(82°C)
Nordel:	-60°F(-51°C) to 280°F(138°C)
Viton:	-40°F(-40°C) to 350°F(176°C)
Teflon:	40°F(4°C) to 220°F(105°C)
Polyurethane:	10°F(-12°C) to 170°F(77°C)
XL TPE:	-20°F(-29°C) to 300°F(149°C)
FDA Hytrel:	-20°F(-29°C) to 220°F(104°C)

Versa-Matic Pump Company
Model E4, Elima-Matic Metallic Pump Parts List (revised 1/98)

Item	Description	Qty.	Pump Model Number				
			E4BA Screen Mount Aluminum*	E4AA Foot Mount Aluminum	E4CA Foot Mount Cast Iron	E4SA Foot Mount Stainless Steel	E4HA Foot Mount Hastelloy C
			Applicable Part Number				
1	Elima-Matic Center Section	1	P31-401				
2	E4 Valve Assembly(items 3 thru 10)	1	P31-200				
3	E4 Valve Body	1	P31-201				
4	Spool	1	P50-104				
4a	Glyd-Ring Assembly	3	P50-104C				
5	Gasket, End Cap	2	P50-110				
6	Gasket, Valve	1	P31-202				
8	End Cap	2	P50-300				
9	Cap Screw	14	P24-208				
10	Stop Nut	2	P24-108				
11	Retainer, Pilot Shaft	2	P50-109				
12	Spacer, Pilot Shaft	2	P50-119				
13	O-Ring, Pilot Valve	6	P24-107				
14	Ring, Pilot Valve	5	P24-106				
15	Pilot Shaft	1	P50-112				
16	Shaft-Rubber Diaphragms	1	P31-103				
16A	Shaft-Teflon Diaphragms	1	P31-102				
17	Bushing O-Ring	2	P24-403				
18	Air Chamber Gasket	2	P31-109				
19	Bushing	1	P31-402				
20	Shaft Stud	2	V161F				
21	Inner Diaphragm Plate	2	V161C				
21A	Inner Diaphragm Plate (Teflon Fitted)	2	V161TI				
22	Outer Diaphragm Plate	2	VB161	WVB161	SVB161	HVB161	
22A	Outer Diaphragm Plate (Teflon Fitted)	2	V161TO	SV161TO		HV161TO	
23	Diaphragm (See below for Material Selection)	2	V163xx				
23A	Back-Up Diaphragm (Used with Teflon Fitted pumps only)	2	V163TFB (Hytre) or V163TFB-1 (Neoprene)				
24	Air Chamber	2	P31-101				
25	Air Chamber Bolt	8	P31-404				
26	Valve Ball	4	V171xx (SEE BELOW FOR MATERIAL SELECTION)				
27	Valve Seat	4	V170xx (SEE BELOW FOR MATERIAL SELECTION)				
27A	Valve Seat O-Ring, (Teflon Fitted only)	4	V170T				
28	Water Chamber	2	V165	WV165	SV165	HV165	
29	Inlet Manifold	1	V167	WV167	SV167	HV167	
30	Discharge Manifold	1	V166	WV166	SV166	HV166	
31	Small Clamp Band	4	V169		SV169		
32	Small clamp Band Bolt	8	V169B		SV169B		
33	Small clamp Band Nut	8	V169C		SV169C		
34	Large Clamp Band	2	P31-110		SP31-110		
35	Large Clamp Band Bolt	4	P31-110B		SP31-110B		
36	Large Clamp Band Nut	4	V164D		SV164D		
37	Air Exhaust Muffler	1	VM-0750				

Diaphragm Part Numbers & Material	Valve Ball Part Numbers & Material	Valve Seat Part Numbers & Material
V163N, Neoprene	V171N, Neoprene	V170A, Aluminum
V163BN, Buna-N	V171BN, Buna-N	V170B, Stainless Steel
V163ND, Nordel	V171ND, Nordel	V170BN, Buna-N
V163VT, Viton	V171VT, Viton	V170N, Neoprene
V163FG, Hytre	V171P, Polyurethane	V170CS, Carbon Steel
V163TX, One piece Teflon diaphragm (no back-up required)	V171SS, Stainless Steel	V170ND, Nordel
	V171TF, Teflon	V170VT, Viton
		V170TPEFG, Hytre
		V170TPEXL, Teflon XL

* For Screen Mount pumps add Screen V168 and (4) Bolts V302G

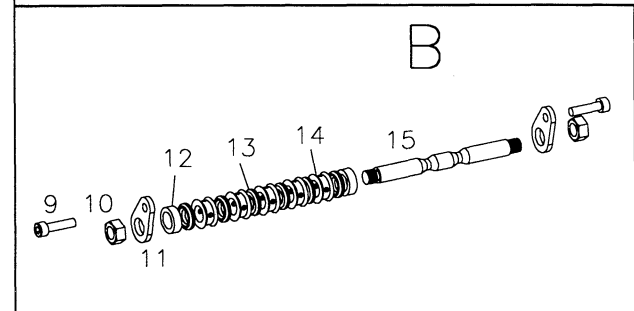
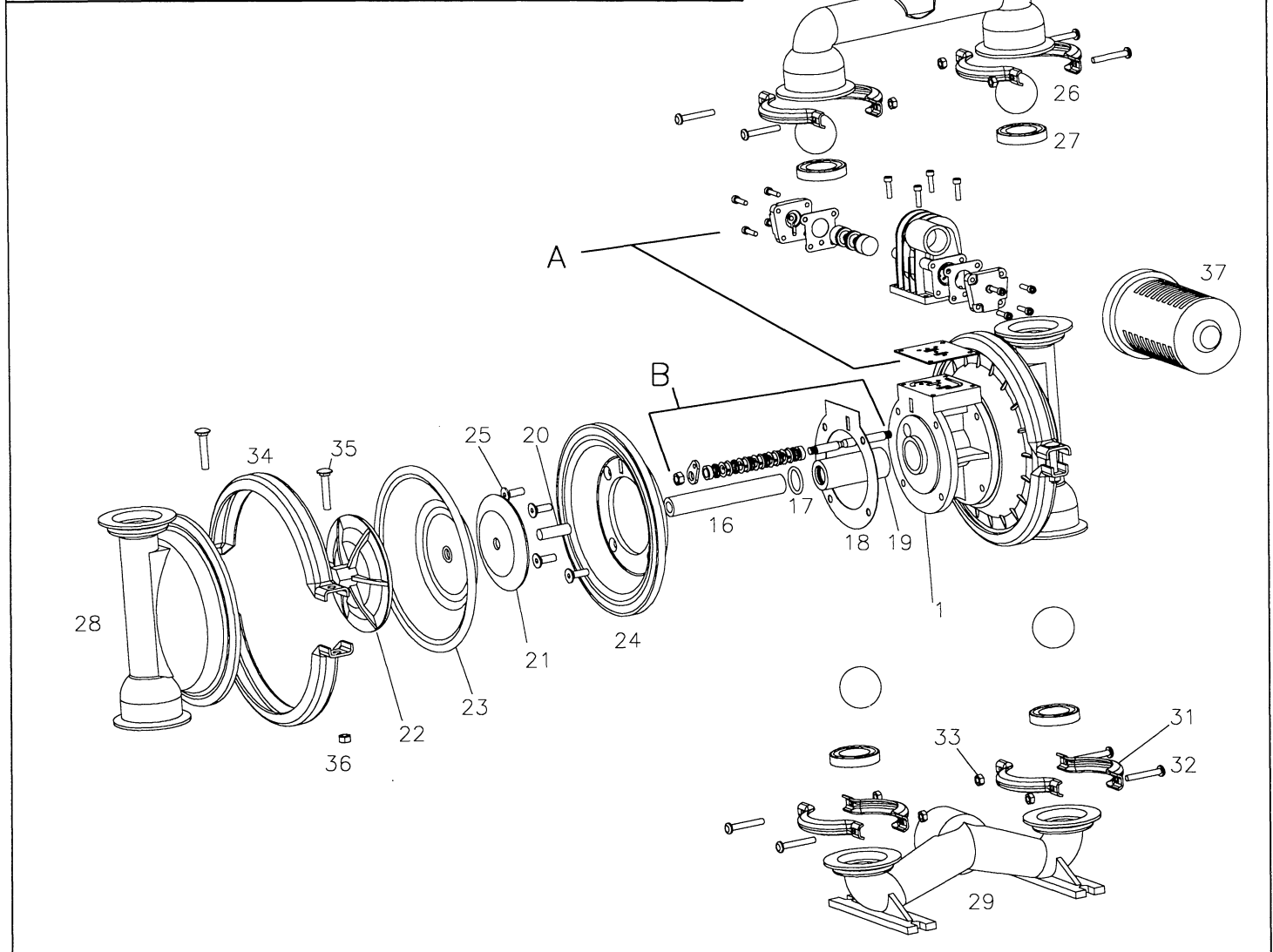
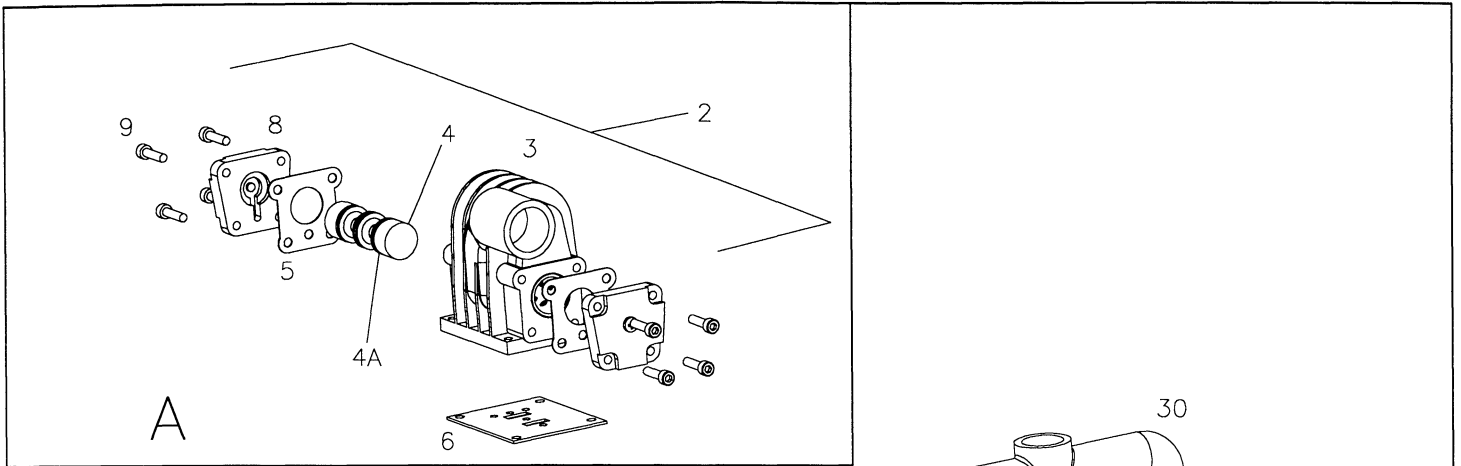

Versa-Matic Pump Company

6017 Enterprise Drive
Export, PA 15632-8969
(724) 327-7867
(724) 327-4300 – fax

www.versamatic.com

ATEX Information

**Products: E1AA Bolted, E1SA Bolted, E2AA Bolted, E2SA Bolted,
E2AA Clamped, E2SA Clamped, E3AA Bolted, E3SA Bolted,
E3AA Clamped, E3SA Clamped, E4SA Bolted, E4AA Clamped,
E4SA Clamped**

This includes the various elastomers and threading options. See Model Sheet for Details

Constructed in year 2003

II 2 G / II 3 G EEx c II T4/T5

Group II, category 2 and 3, Gas explosive atmosphere, constructional safety ignition protection, Temperature rating "T4" for fluids up to 130°C and "T5" for fluid up to 95°C. Temperatures are not to exceed the ATEX ratings.

Local authorized distributor:

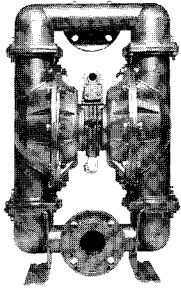

**ELIMA-MATIC®
ANTI-STALLING PUMPS**

- ☐ Virtually eliminates pump stalling caused by air valve system freeze-ups
- ☐ Anti-stalling, non-icing, lubrication-free air valve system.
- ☐ Available in 1/2", 1", 1 1/4", 2" and 3" sizes
- ☐ Wide selection of materials of construction—including 1/2", 1" and 2" plastic models

PLASTIC PUMPS FOR SOLVENTS AND CHEMICALS

- ☐ Exceptional corrosion resistance
- ☐ Wide selection of materials of construction for wetted and non-wetted parts
- ☐ Leak free bolted construction
- ☐ Also available in 1/2", 1", 1 1/2" and 2" with the Elima-Matic anti-stalling air valve system

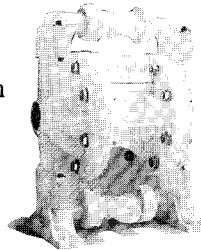

Elima-Matic 2:1 High Pressure Pump

- ☐ Cast in 150lbs ANSI/DIN flanges
- ☐ Constructed of 316 stainless steel
- ☐ Can create discharge pressure over 200 psi
- ☐ Leak-Free bolted design

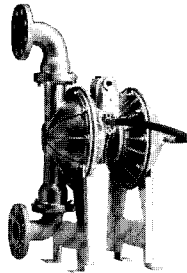

VERSA-DOME® DIAPHRAGMS

- ☐ The simple, smooth design eliminates complex angles allowing for 3 to 4 times the flex life of standard diaphragms.
- ☐ So flexible they can be installed and removed without the use of pry bars
- ☐ Has lower start up pressure than standard diaphragm.
- ☐ Available Neoprene, Buna-N, Hytrel, Nordel®, Viton® and XL.
- ☐ For use in Versa-Matic and Wilden 1/2", 2", 3" pumps.



VERSA-TUFF TEFLON DIAPHRAGMS

- ☐ Single piece diaphragm combining the chemical resistance of Teflon with the flex life of rubber.*
- ☐ Three times the burst strength of ordinary Teflon overlays
- ☐ More flexible and 100% bonded to the reinforced rubber backing
- ☐ Diaphragms can be placed into Wilden® M4 and M8 pumps

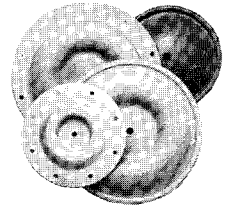

GENUINE VERSA-MATIC REPLACEMENT PARTS AND RETRO FIT CENTER SECTIONS

- ☐ Upgrade V-series and Wilden® M4, M8, and M15 pumps with an Elima-Matic retro fit center section
- ☐ For complete repair of Versa-Matic pumps and Wilden® M4, M8 and M15 metallic pumps
- ☐ Cost-saving elastomer kits for any Versa-Matic pump or Wilden® M1, M2, M4, M8 and M15 pumps
- ☐ Diaphragm and elastomer repair kits available in Buna-N, Neoprene, Nordel®, Teflon®, Viton®, Thermo Plastics Hytrel®, and XL

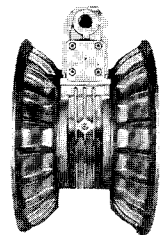

Your local authorized distributor:

FOOD AND SANITARY PUMPS

SANITARY PUMPS

- ☐ FDA approved for use with milk and milk products
- ☐ Constructed of 316 stainless steel
- ☐ Surface finish of 32 micro-inch or better
- ☐ Removable ball cages
- ☐ Easy clean Tri-clamp® connections

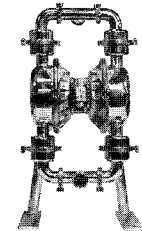

FOOD PROCESSING PUMPS

- ☐ Constructed of 316 stainless steel
- ☐ FDA approved
- ☐ Tri-clamp® connections
- ☐ Over-sized clamp wing nuts for disassembly

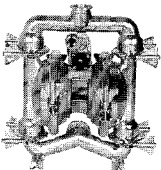

VERSA-MATIC PUMP

6017 Enterprise Drive
Export, PA 15632-8969
(724) 327-7867 • Fax: (724) 327-4300

www.versamatic.com

* Life cycle may vary according to extreme start-up conditions, chemicals and abrasive fluids. To prolong diaphragm life, Versa-Matic recommends a gradual increase in air supply on pump start-up.

Elima-Matic®, Versa-Dome®, Versa-Matic® and VR® are registered trademarks or trademarks of Versa-Matic Tool, Inc. Some Versa-Matic Tool, Inc. products are subject to patent pending applications and issued patents, Elima-Matic U.S. Patent No. 5,326,234. Hytrel®, Nordel®, Teflon® and Viton® are registered trademarks of DuPont. Tri-Clamp® is a registered Trademark of the Tri-Clamp, Inc. Wilden® is a registered Trademark of Wilden Pump and Engineering Co.

