

E8 Mini-Matic™ 3/8" Bolted Plastic Pumps Operating Instructions

**VERSA-MATIC
PUMP**

Member of
Hydraulic
INSTITUTE

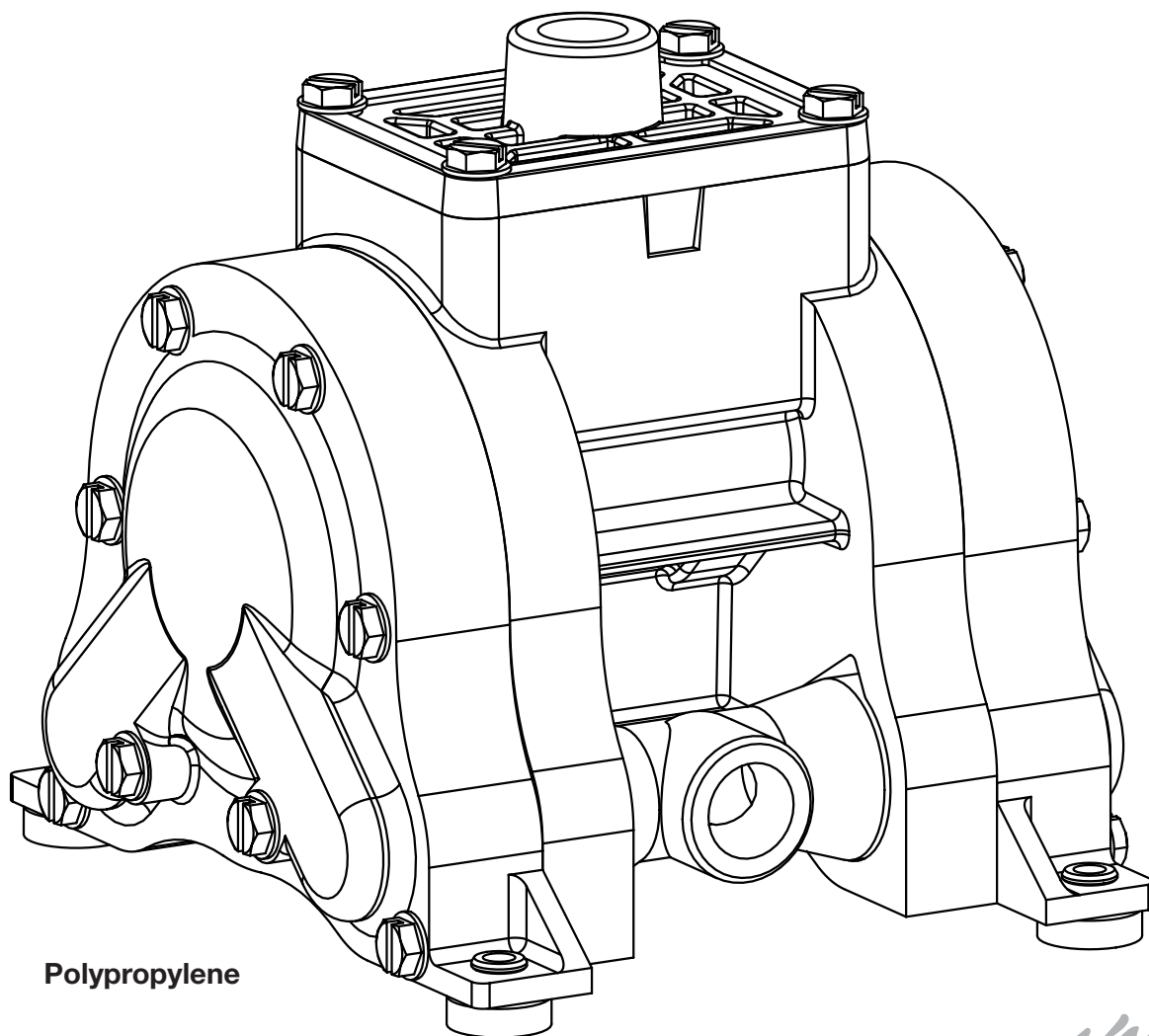

Polypropylene



IDEX
IDEX CORPORATION

SAFETY WARNINGS

Read these instructions completely before installation and start-up. It is the responsibility of the purchaser to retain this manual for reference. Failure to comply with the recommendations stated in this manual could result in death, serious bodily injury and/or property damage including damage to the pump and/or voiding the factory warranty.

Correct pump selection is crucial to the pump operation. Please assure pressure, temperature and chemical compatibility before installation. Please consult Versa-Matic Pump, Engineering Specifications, Chemical Compatibility Chart, or your distributor if in doubt about any application.

Operating Limitations for Various Elastomers

Neoprene	0°F (-18°C) to 200°F (93°C)
Buna-N	10°F (-12°C) to 180°F (82°C)
Nordel	-60°F (-51°C) to 280°F (138°C)
Viton	-40°F (-40°C) to 350°F (176°C)
Teflon	40°F (4°C) to 220°F (105°C)
Polyurethane	10°F (-12°C) to 170°F (77°C)
XL TPE	-20°F (-29°C) to 300°F (149°C)
Geolast	-40°F (-40°C) to 257°F (125°C)
FDA Hytrel	-20°F (-29°C) to 220°F (104°C)

Operating Limitations for Plastic Pumps

Kynar (PVDF)	10°F (-12°C) to 225°F (107°C)
Polypropylene	32°F (0°C) to 175°F (79°C)

Maximum temperature limits are based upon mechanical stress only. Certain chemicals and environment conditions significantly reduce maximum safe temperature limits.

Before pump operation, inspect all gasketed fasteners for looseness caused by gasket creep. Re-torque all loose fasteners to prevent leakage. Follow recommended torques stated in this manual. Failure of the sealing components creates the possibility of jetting or forceful discharge of pumped material at a potentially harmful velocity.

Be certain that approved eye protection and protective clothing are always worn during installation, service, maintenance or when in the vicinity of the pump. Failure to follow these recommendations may result in serious injury or death.

Never allow the piping system to be supported by the pump manifolds or valve housing. The manifolds and valve housing are not designed to support any structural weight and failure of the pump may result.

Take action to prevent static sparking. Fire or explosion can result, especially when handling flammable liquids. The pump, piping, valves, containers, or other miscellaneous equipment must be grounded.

Noise levels can exceed 85 dBA. Take precautions to prevent personal injury due to excessive pump noise.

Do not exceed pump maximum operating pressure (found on label and/or operating manual.)

Before doing any maintenance or repair on this pump, be certain all pressure is completely vented for the pump, suction, discharge, piping, and all other openings.

In the event of a diaphragm rupture, pumped material may enter the air end of the pump and be discharged into the atmosphere. If pumping a product that is hazardous or toxic, the air exhaust must be piped to an appropriate area for safe disposition.

SPECIFICATIONS AND PERFORMANCE

Versa-Matic Mini-Matic Model MM 3/8" Bolted Plastic Pump

Flow Rate

Adjustable to 0-8.2 gpm (31 lpm)

Port Size

Suction 3/8" Female NPT (BSP)

Discharge 3/8" Female NPT (BSP)

Air Inlet 0.25" Female NPT

Air Exhaust 0.25" Female NPT

Suction Lift 11' (3.4 m) Dry

Teflon 11' (3.4 m) Dry

Max. Particle Size (Dia.) . . 0.10" (2.5 mm)

dB(A) Reading 78 dB(A)

Shipping Weight

Polypropylene 3 lbs (1.4 kg)

Kynar 3 lbs (1.4 kg)

**Caution: do not exceed 100 psig
(6.8 bar) liquid or air supply pressure.**

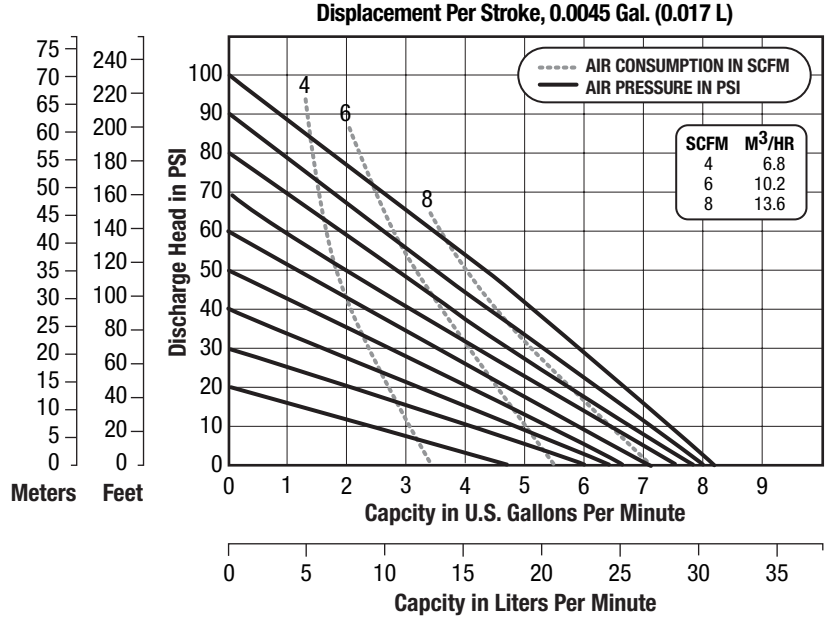

MM 3/8" Bolted Plastic Pump

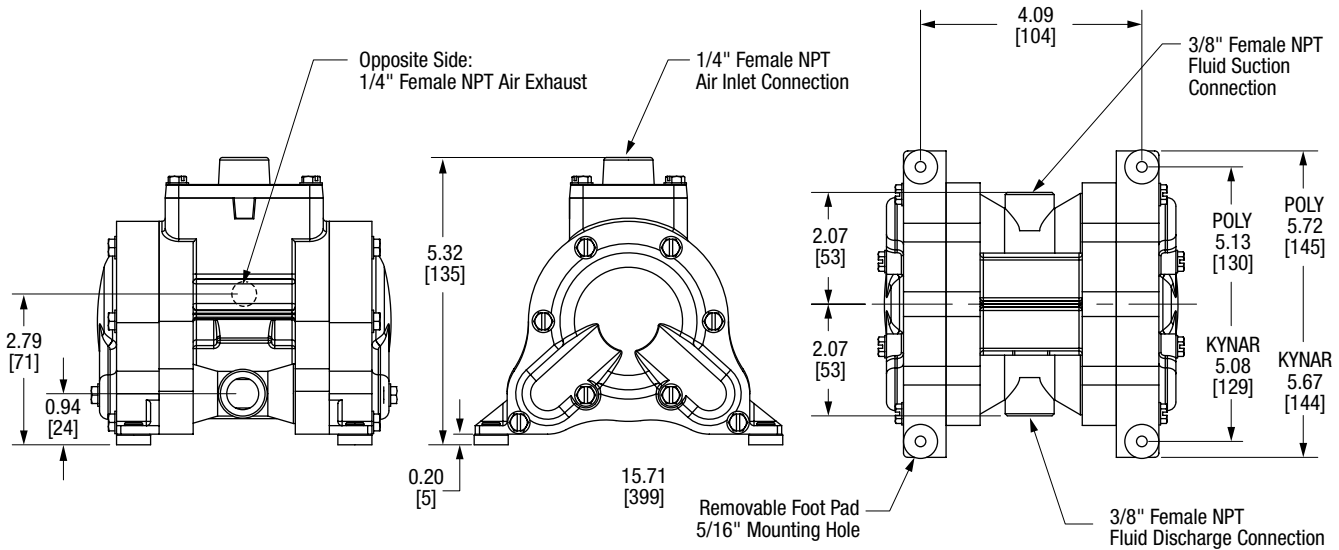

INSTALLATION, OPERATION AND MAINTENANCE

Installation

The pump should be mounted in a vertical position. In permanent installations, the pump should be attached to plant piping using a flexible coupling on both the intake and discharge connections to reduce vibration to the pump and piping. To further reduce vibration, a surge suppressor next to the pump may be used.

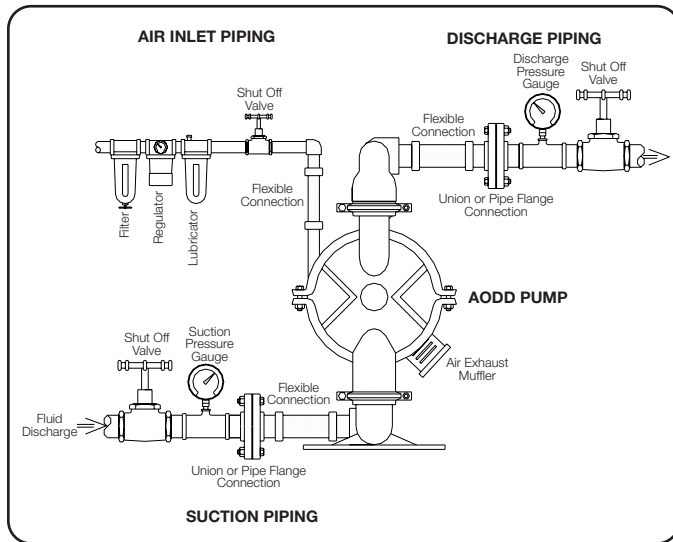

Suction pipe size should be at least the same diameter as the inlet connection size, even larger if highly viscous fluid is to be pumped. If suction hose is used, it must be of a non-collapsible reinforced type. Discharge piping should be of at least the same diameter as the discharge connection. It is critical,

especially on the suction side of the pump, that all fittings and connections are air tight or pumping efficiency will be reduced and priming will be difficult.

Make certain the air supply line and connections and compressor are capable of supplying the required pressure and volume of air to operate the pump at the desired flow rate. The quality of the compressed air source should be considered. Air that is contaminated with moisture and dirt may result in erratic pump performance and increased maintenance cost as well as frequent process “down time” when the pump fails to operate properly.

Pump Operation

The pump is powered by compressed air. Compressed air is directed to the pump air chamber by the main air valve. The compressed air is separated from the fluid by a membrane called a diaphragm. The diaphragm in turn applies pressure on the fluid and forces it out of the pump discharge. While this is occurring, the opposite air chamber is de-pressurized and exhausted to atmosphere and fluid is drawn into the pump suction. The cycle again repeats, thus creating a constant reciprocating action which maintains flow through the pump. The flow is always in through the bottom suction connection and out through the top discharge connection. Since the air pressure acts directly on the diaphragms, the pressure applied to the fluid roughly approximates the air supply pressure supplied to the main air valve.

Recommended Piping Connections

Pump Size	Minimum Air Line Size	Minimum Suction Line Size
1/4"	1/4"	1/4"
3/8"	1/4"	3/8"
1/2"	1/2"	1/2"
1"	1/2"	1"
1-1/2"	1/2"	1-1/2"
2"	1/2"	2"
3"	3/4"	3"

MM 3/8" Plastic Pump Torque Settings

Water Chamber Bolts	50 in-lbs (5.7 N-m)
Diaphragm Plates — Rubber	60 in-lbs (6.8 N-m)
Diaphragm Plates — Teflon	60 in-lbs (6.8 N-m)
Air Valve Cap Screws	35 in-lbs (3.9 N-m)

Elastomer Suffix Codes

Suffix Code	Material
A	Acetal
BN	Buna-N, Nitrile
N	Neoprene
ND	Nordel, EPDM
TF	Teflon
FG	Hytrell
XL	XL, Santoprene
VT	Viton
TX	Bonded Teflon

PARTS LIST

AIR VALVE ASSEMBLY				
Item	Description	Qty.	Standard: Polypropylene	
	Air Valve Assembly (Includes items 1-10)		E800	
1	Valve Body	1	E800A	
2	Valve Spool	1	E500B	
3	Valve Spool U-Cup	2	P98-104A	
4	End Cap	2	E800D	
5	End Cap O-Ring	2	E500E	
8	Air Diverter	1	E500G	
9	Valve Insert	1	E500H	
10	Valve Gasket	1	E800J	
11	Valve Screw	4	10-050	
AIR END ASSEMBLY				
Item	Description	Qty.	Standard: Polypropylene	
12	Center Section	1	E801A	
18	Pilot Shaft	1	E803A	
19	Pilot Shaft Spacer	5	E503C	
20	Pilot Shaft O-Ring	6	E503B	
21	Pilot Shaft Snap Ring	2	E503D	
22	Shaft Retainer	2	E801B	
25	Shaft Retainer Screw	4	E501C	
33	Muffler	1	06-034	
DIAPHRAGM ASSEMBLY				
Item	Description	Qty.	TPE	
34	Main Shaft O-Ring	2	E503B	
35	Main Shaft	1	10-028	
37	Inner Diaphragm Plate	2	C126	
38	Outer Diaphragm Plate	2	10-023(poly) 10-040(kynar)	
40	Diaphragm	2	10-032(XL) (10-033)Geolast	
41	Back-Up Diaphragm	2	NR	
WET END ASSEMBLY				
Item	Description	Qty.	Standard: Polypropylene	Option 1: Kynar
44	Water Chamber	2	10-002	10-036
45	Water Chamber Bolt (Long)	4	10-052	10-052
46	Water Chamber Bolt (Short)	12	10-051	10-051
50	Valve Seat	4	10-012(XL) 10-029(Geolast)	10-012(XL) 10-029(Geolast)
52	Valve Stem	4	10-005	10-005
53	Spring	4	10-030	10-030
60	Manifold	2	10-003	10-037
62	Foot Pad	4	10-035	10-035

EXPLODED VIEWS

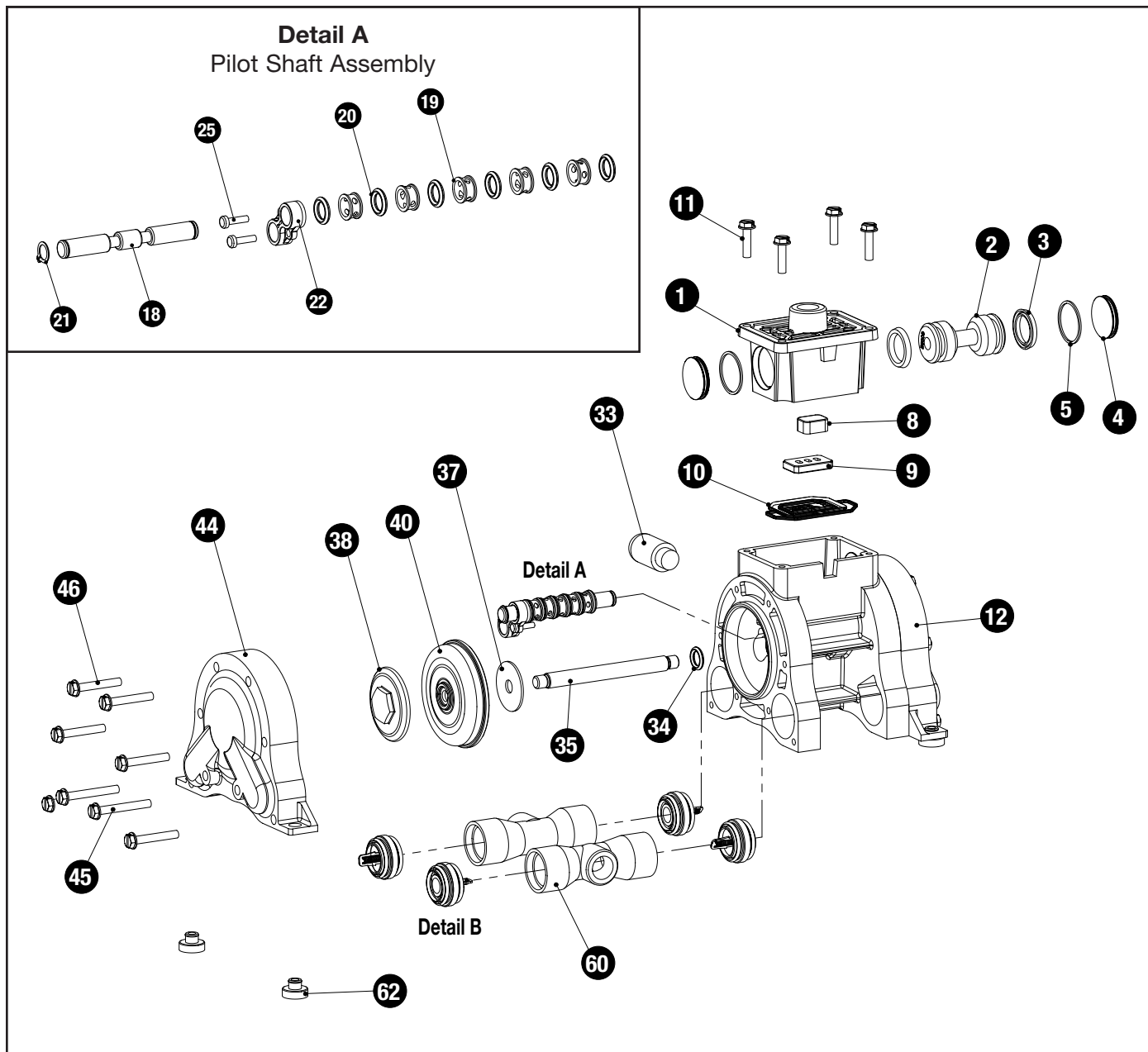

REPAIR & MAINTENANCE KITS

Air End Kit			
Item	Description	Qty	Part Number
3	Valve Spool U-Cup	2	P98-104A
5	End Cap O-Ring	2	E500E
8	Air Diverter	1	E500G
9	Valve Insert	1	E500H
10	Valve Gasket	1	E800J
20	Pilot Shaft O-Ring	6	E503B
34	Main Shaft O-Ring	2	E503B

Wetted End Kits	
Part #	Description
E8 XL KIT	XL Elastomer Kit
E8 G KIT	Geolast Elastomer Kit

