

Zenith® Pumps 9000 Series Gear Pumps

**Now with
Magnetic
Coupling
Drive**

A New Generation
of Metering Pump.



Precise, Pulseless, Repeatable
Performance In Industrial
Metering Applications

anything **Parker**
Possible.™

9000 Series

The Zenith 9000 Series was developed as a true precision metering gear pump for application into a variety of industrial processes. The design utilizes high AGMA standard external spur gears of optimum geometry, enclosed within a close tolerance housing assembly, resulting in a precise volume of fluid dispensed per shaft revolution.

The housing is constructed from a precision ground and lapped 3-plate assembly. The plate assembly is aligned with dowels to allow close control of operating clearances. This construction method in combination with several proprietary internal features is what ensures Precise, Pulseless and Reliable flow under varying process conditions.

Coupled with a pre-packaged integrated closed loop speed control and compact motor driver assembly (AC or DC), Zenith is able to provide the most precise and flexible metering gear pump on the market.

Zenith Pumps has been designing and manufacturing precision metering gear pumps since its inception in 1926. Over the years' Zenith has been distinguished as an innovator in the application of gear pump technology by a variety of industries and end-users. The 9000 series is Zenith's latest generation of industrial metering pumps that are based upon years of practical application knowledge, and pioneering research and development.

For years, engineers have relied on Zenith to provide Precision Fluid Handling Solutions for the most difficult pumping applications. This is why Zenith gear pumps can be found wherever Precise, Pulseless and Reliable fluid metering performance is required. Please review the following with this in mind, and be sure to contact us to discuss your specific needs — we are here to help make your metering applications simpler for you and your customers.

Application Samples from A to Z

Adhesives	Cereal	Inks	Polymers	Spraying
Additives	De-ionized Water	Inhibitors	Plastics	Tackifiers
Acids & Bases	Dyes	Injection	Polyurethanes	Tar
Abrasives	Defoamer	Juices	Plasticizers	Urethanes
Asphalt	Detergents	Kerosene	Polyols	Varnish
Beverages	Emulsions	Lubricants	Pigments	Viscose
Biotech	Epoxies	Mineral Oil	Potting	Vitamins
Bottoms	Fibers	Monomers	Pitch	Water Solutions
Bonding Agents	Flavorings	Nutrients	Quartz Slurries	Water Treatment
Calcium Stearate	Fragrances	Oils	Resins	Waxes
Candy	Fuels	Oligomers	Sealants	Xylene
Catalysts	Foodstuff	Oxide Slurries	Silicones	Yeast
Chemicals	Foams	Paints	Solvents	Zinc Oxide
Coatings	Gasketing	Perfumes	Surfactants	and many,
Colorants	Glycols	Pharmaceuticals	Slurries	many more...
Cosmetics	Hot Melts	Pill Coatings		

Benefits

High Accuracy: Stable repeatable flows are assured under varying conditions of temperature, viscosity and pressure.

Uniform Metered Flow: Unique design offers virtually pulseless flow, without valves or flexible elements that add complexities, increase cost and hinder performance.

Engineered Solutions: Proven Applications: A variety of pump heads and driver combinations have been pre-configured to provide a range of standard installation options, meeting OSHA, UL, EC and Din Standards.

Active Flowmeter Concept: Unparalleled mechanical precision, combined with closed loop accuracy, ensures exact volume per revolution without expensive flow meters.

Low Cost of Ownership: Only three moving parts, and hardened abrasion resistant materials provide excellent wear, corrosion and self-lubricating performance.

Proven Applications: Years of practical application experience, backed by a technical staff with a variety of technical credentials eliminates the guesswork.

Pump Head Options:

B-9000 Series: *General-purpose industrial duty* ***Constructed of through hardened 400 series stainless steel***

Capacities (cc/rev):	0.05, 0.3, 0.6, 1.2, 2.4, 4.5, 9.0, 15, 30, 45, 90	Seals:	Single Mechanical, Double Lip, Packed or Magnetic
Recommended Speed:	.05 to 30 cc/rev, up to 500 RPM 45 & 90 cc/rev, up to 300 RPM	Rotation:	Clockwise (CW) facing drive shaft
Flow Range:	up to 27,000 cc/Minute up to 7 gpm	Port Connections:	Metric thread or SAE 61 Standard
Inlet Pressure:	300 psi (20 Bar) Maximum	Optional Port Adapters:	M12 X 1/4" NPT..... 0.05 – 2.4 cc/rev 1/2" SAE X 1/2" NPT..... 4.5 – 9.0 cc/rev 3/4" SAE X 3/4" NPT..... 15 – 30 cc/rev 1-1/4" SAE X 1-1/4" NPT.. 45 – 90 cc/rev
Outlet Pressure:	1000 psi (70 Bar) Maximum	Optional Band heaters:	150 Watt, 115 VAC..... 0.05 – 2.4 cc/rev 325 Watt, 115 VAC..... 4.5 – 9.0 cc/rev 650 Watt, 230 VAC..... 15 – 30 cc/rev 1500 Watt, 230 VAC..... 45 – 90 cc/rev
Differential Pressure:	20 to 1000 psi. (viscosity dependent)		
Temperature:	0° F (-18° C) Minimum 400° F (205° C) Maximum (with magnetic coupling seal) 645° F (340° C) Maximum (dependant on shaft seal materials)		

C-9000 Series: *Corrosive & Poor Lubricating Fluids* ***Constructed of hardened 316SS and compatible materials***

Capacities (cc/rev):	0.3, 0.6, 1.2, 2.4, 4.5, 9.0	Seals:	Single Mechanical, Double Lip, or Magnetic
Recommended Speed:	up to 1000 rpm	Rotation:	Clockwise (CW) facing drive shaft
Flow Range:	up to 9,000 cc/Minute up to 2.4 gpm	Port Connections:	Metric thread or SAE 61 Standard
Inlet Pressure:	300 psi (20 Bar) Maximum	Optional Port Adapters:	M12 X 1/4" NPT..... 0.3 – 2.4 cc/rev 1/2" SAE X 1/2" NPT..... 4.5 – 9.0 cc/rev
Outlet Pressure:	1000 psi (70 Bar) Maximum	Optional Band heaters:	150 Watt, 115 VAC..... 0.3 – 2.4 cc/rev 325 Watt, 115 VAC..... 4.5 – 9.0 cc/rev
Differential Pressure:	20 to 1000 psi. (viscosity dependent)		
Temperature:	-40° F (- 40° C) Minimum 350° F (175° C) Maximum		

H-9000 Series: *High Temperature and Abrasive Fluids* ***Constructed of through-hardened high speed tool steels***

Capacities (cc/rev):	0.3, 0.6, 1.2, 2.4, 4.5, 9.0, 15, 30, 45, 90	Seals:	Single Mechanical, Double Lip seal or Packed configurations
Recommended Speed:	0.3 to 30 cc/rev, up to 500 RPM 45 & 90 cc/rev, up to 300 RPM	Rotation:	Clockwise (CW) facing drive shaft
Flow Range:	up to 27,000 cc/Minute up to 7 gpm	Port Connections:	Metric thread or SAE 61 Standard
Inlet Pressure:	1000 psi (70 Bar) Maximum	Optional Port Adapters:	M12 X 1/4" NPT..... 0.3 – 2.4 cc/rev 1/2" SAE X 1/2" NPT..... 4.5 – 9.0 cc/rev 3/4" SAE X 3/4" NPT..... 15 – 30 cc/rev 1-1/4" SAE X 1-1/4" NPT.. 45 – 90 cc/rev
Outlet Pressure:	2500 psi (175 Bar) Maximum	Optional Band heaters:	150 Watt, 115 VAC..... 0.3 – 2.4 cc/rev 325 Watt, 115 VAC..... 4.5 – 9.0 cc/rev 650 Watt, 230 VAC..... 15 - 30 cc/rev 1500 Watt, 230 VAC 45 - 90 cc/rev
Differential Pressure:	20 to 2500 psi. (viscosity dependent)		
Temperature:	32° F (0.0° C) Minimum 950° F (510° C) Max. (With packing seal and high temperature fasteners)		

Standard Metering Systems (shown with ZVD AC Controller)

- 1/2 - 2 HP AC Vector Drive
- 230 VAC, 1 or 3 phase (1/2 – 2 HP)
- 460 VAC 3 phase
- Closed loop PID control
- Engineering unit or frequency setpoint
- Jog
- 5 standard inputs
- 6 multifunction inputs
- 1 form C relay multifunction output
- 3 open collector multifunction outputs
- Password protection
- Adjustable current limit
- RS-485 Modbus serial communications
- Analog I/O

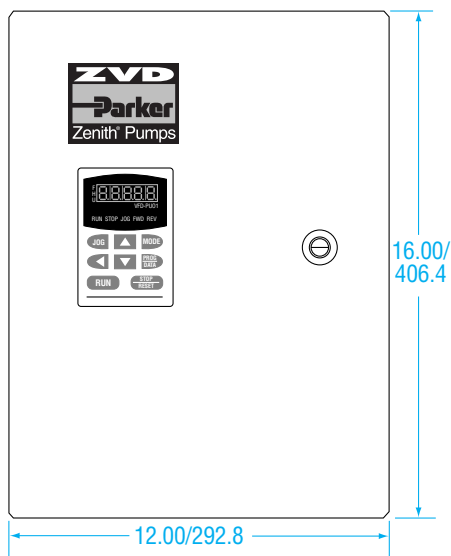

Note: All standard systems include NPT port adapters. See dimensions "L" and "Z" in the chart below for details. If the NPT adapters are removed, refer to individual pump drawings for information on port connections.

Note: ZeDrive™ DC controllers and motors are also available. For more information, please visit www.zenithpumps.com

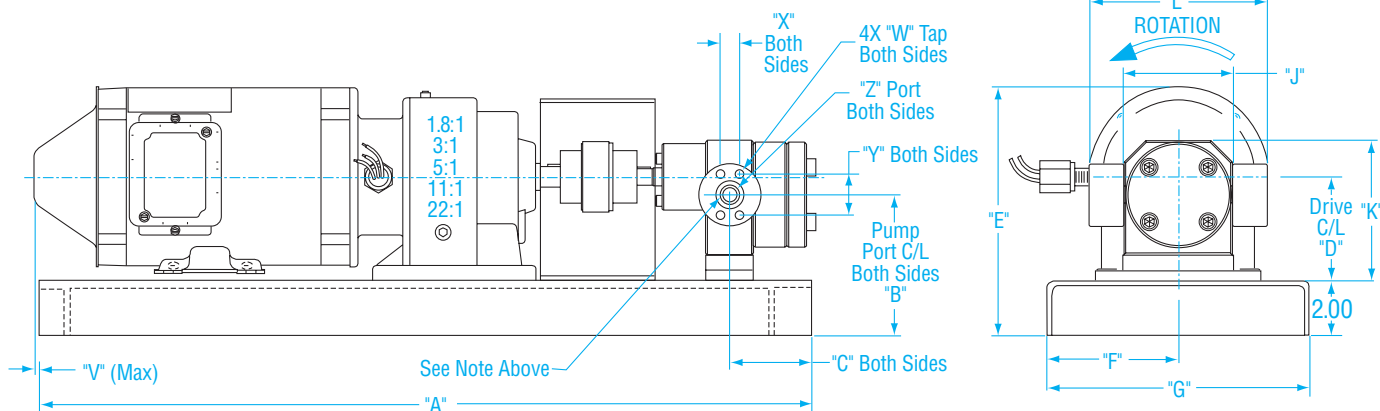
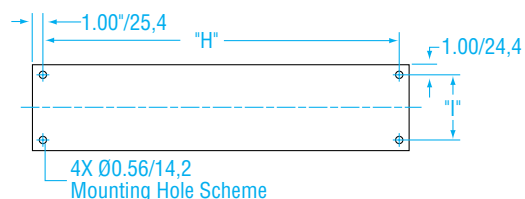

System/Dim.	A	B	C	D	E	F	G	H	I	J	K	L	V	W	X	Y	Z	NEMA IEC
1/2 hp 05-2.4cc/rev*	28.00 711.2	5.28 134.1	3.39 86.1	3.74 95.0	9.00 228.6	4.75 120.7	9.50 241.3	26.00 660.4	7.50 190.5	2.76 70.1	4.65 118.1	4.40 111.8	0.17 4.3	N/A N/A	N/A N/A	N/A N/A	1/4 NPT 1/4 NPT	56C 71
1/2 hp 4.5-9cc/rev*	28.00 711.2	5.11 129.8	2.98 75.7	4.11 104.4	9.00 228.6	4.75 120.7	9.50 241.3	26.00 660.4	7.50 190.5	3.94 100.1	5.07 128.8	6.44 163.6	0.17 4.3	M8 x 12DP M8 x 12DP	0.69 17.5	1.50 38.1	1/2 NPT 1/2 NPT	56C 71
1 hp 4.5-9cc/rev*	36.00 914.4	5.86 148.8	8.22 208.8	4.51 114.6	10.01 254.3	5.00 127.0	10.00 254.0	34.00 863.6	8.00 203.2	3.94 100.1	5.82 147.8	6.44 163.6	N/A N/A	M8 x 12DP M8 x 12DP	0.69 17.5	1.50 38.1	1/2 NPT 1/2 NPT	56C 80
2 hp 4.5-9cc/rev*	36.00 914.4	5.86 148.8	8.22 208.8	4.51 114.6	10.01 254.3	5.00 127.0	10.00 254.0	34.00 863.6	8.00 203.2	3.94 100.1	5.82 147.8	6.44 163.6	3.37 85.6	M8 x 12DP M8 x 12DP	0.69 17.5	1.50 38.1	1/2 NPT 1/2 NPT	145TC 90
1/2 hp 15-30cc/rev†	36.00 914.4	5.19 131.8	7.63 193.8	4.11 104.4	9.61 244.1	5.00 127.0	10.00 254.0	34.00 863.6	8.00 203.2	5.00 127.0	5.69 144.5	7.50 190.5	N/A N/A	M10 x 22DP M10 x 22DP	0.88 22.4	1.88 47.8	3/4 NPT 3/4 NPT	56C 71
1 hp 15-30cc/rev†	36.00 914.4	5.60 142.2	7.55 191.8	4.51 114.6	10.01 254.3	5.00 127.0	10.00 254.0	34.00 863.6	8.00 203.2	5.00 127.0	6.10 154.9	7.50 190.5	N/A N/A	M10 x 22DP M10 x 22DP	0.88 22.4	1.88 47.8	3/4 NPT 3/4 NPT	56C 80
2 hp 15-30cc/rev†	36.00 914.4	5.60 142.2	7.55 191.8	4.51 114.6	10.01 254.3	5.00 127.0	10.00 254.0	34.00 863.6	8.00 203.2	5.00 127.0	6.10 154.9	7.50 190.5	N/A N/A	M10 x 22DP M10 x 22DP	0.88 22.4	1.88 47.8	3/4 NPT 3/4 NPT	145TC 90
1 hp 45-90cc/rev†	36.00 914.4	6.14 156.0	6.12 155.4	5.38 136.7	10.89 276.6	5.00 127.0	10.00 254.0	34.00 863.6	8.00 203.2	6.89 175.0	7.59 192.8	9.37 238.0	N/A N/A	M12 x 24DP M12 x 24DP	1.19 30.2	2.31 58.7	1-1/4 NPT 1-1/4 NPT	56C 80
2 hp 45-90cc/rev†	36.00 914.4	6.14 156.0	6.12 155.4	5.38 136.7	10.89 276.6	5.00 127.0	10.00 254.0	34.00 863.6	8.00 203.2	6.89 175.0	7.59 192.8	9.37 238.0	N/A N/A	M12 x 24DP M12 x 24DP	1.19 30.2	2.31 58.7	1-1/4 NPT 1-1/4 NPT	145TC 9

*Available for B-9000, C-9000 and H-9000, †Available for B-9000 and H-9000

9000 MD Systems (shown with ZeDrive™ DC Controller)

- 1 / 4 – 2 HP SCR DC Drive
- 115 VAC, 1 phase (90 VDC Motors)
- 230 VAC, 1 phase (180 VDC Motors)
- Master or Follower Modes
- Closed loop PID control
- 4 engineering unit setpoints
- Jog
- 13 standard inputs
- 5 open collector outputs
- Keypad lockout
- Adjustable current limit
- RS-422 serial communications
- Optional Analog I/O (12 bit)

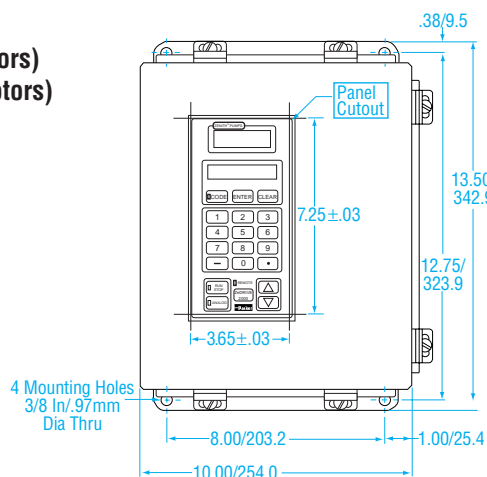

Note: All standard systems include NPT port adapters. See dimensions "L" and "Z" in the chart below for details. If the NPT adapters are removed, refer to individual pump drawings for information on port connections.

Note: ZVD AC controllers and motors are also available. For more information, please visit www.zenithpumps.com

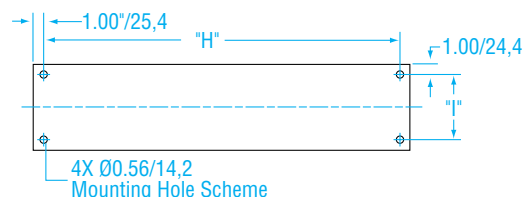

9000MD Direct Drive Magnetic Coupling

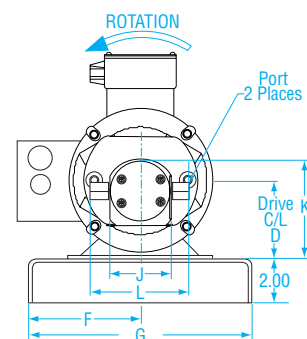
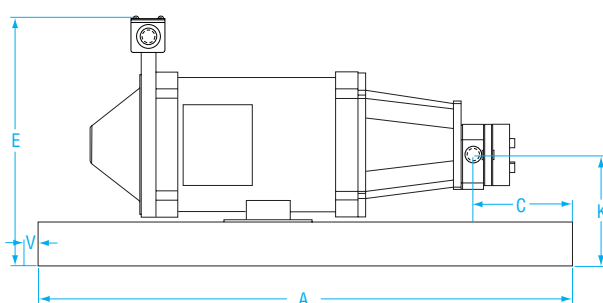

9000MD Magnetic Coupling with reducer

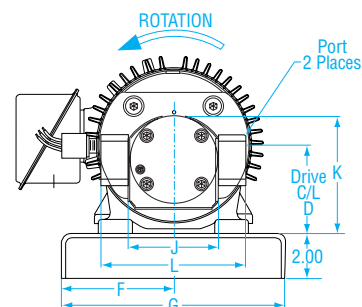
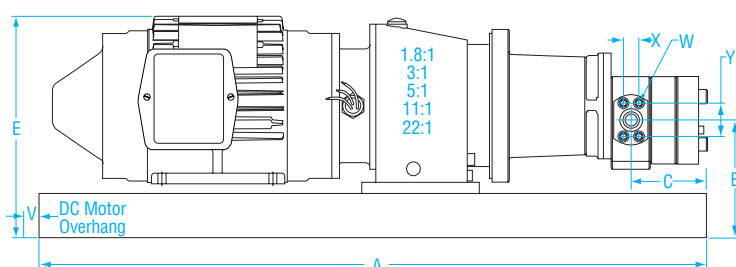

System Configuration	Coupling Torque	"A"	"B"	"C"	"D"	"E"	"F"	"G"	"H"	"I"	"J"	"K"	"L"	"V"	"W"	"X"	"Y"	"Z"	NEMA IEC	
0.05 - 2.4 cc/rev 1/2 HP Direct Drive	23 in-lb	24.00	5.01	4.50	5.47	11.20	5.00	10.00	22.00	8.00	2.76	4.38	4.45	N/A	N/A	N/A	N/A	1/4 NPT	56-C	
	609.60	127.25	114.30	138.94	284.48	127.00	254.00	558.80	203.20	70.10	111.25	113.03	N/A	N/A	N/A	N/A	N/A	1/4 NPT	71	
0.05 - 2.4 cc/rev 1/2 HP with Reducer	23 in-lb	30.00	5.47	4.50	5.94	11.70	5.00	10.00	28.00	8.00	2.76	4.85	4.45	N/A	N/A	N/A	N/A	1/4 NPT	56-C	
	762.00	138.94	114.30	150.88	297.18	127.00	254.00	711.20	203.20	70.10	123.19	113.03	N/A	N/A	N/A	N/A	N/A	1/4 NPT	71	
0.05 - 2.4 cc/rev 1 HP Direct Drive	55 in-lb	24.00	5.01	4.50	5.47	11.20	5.00	10.00	22.00	8.00	2.76	4.38	4.45	N/A	N/A	N/A	N/A	1/4 NPT	56-C	
	609.60	127.25	114.30	138.94	284.48	127.00	254.00	558.80	203.20	70.10	111.25	113.03	N/A	N/A	N/A	N/A	N/A	1/4 NPT	80	
0.05 - 2.4 cc/rev 1 HP with Reducer	55 in-lb	30.00	5.47	4.50	5.94	11.70	5.00	10.00	28.00	8.00	2.76	4.85	4.45	0.09	N/A	N/A	N/A	N/A	1/4 NPT	56-C
	762.00	138.94	114.30	150.88	297.18	127.00	254.00	711.20	203.20	70.10	123.19	113.03	2.29	N/A	N/A	N/A	N/A	1/4 NPT	80	
4.5 - 9.0 cc/rev 1/2 HP Direct Drive	110 in-lb	24.00	4.84	4.00	5.47	11.20	5.00	10.00	22.00	8.00	3.94	4.81	6.50	N/A	M8 x 12DP	0.69	1.50	1/2 NPT	56-C	
	609.60	122.94	101.60	138.94	284.48	127.00	254.00	558.80	203.20	100.08	122.17	165.10	N/A	M8 x 12DP	17.53	38.10	1/2 NPT	71		
4.5 - 9.0 cc/rev 1/2 HP with Reducer	110 in-lb	30.00	5.28	3.44	5.94	11.70	5.00	10.00	28.00	8.00	3.94	5.25	6.50	N/A	M8 x 12DP	0.69	1.50	1/2 NPT	56-C	
	762.00	134.11	87.38	150.88	297.18	127.00	254.00	711.20	203.20	100.08	133.35	165.10	N/A	M8 x 12DP	17.53	38.10	1/2 NPT	71		
4.5 - 9.0 cc/rev 1 HP Direct Drive	110 in-lb	24.00	4.84	4.00	5.47	11.20	5.00	10.00	22.00	8.00	3.94	4.81	6.50	0.06	M8 x 12DP	0.69	1.50	1/2 NPT	56-C	
	609.60	122.94	101.60	138.94	284.48	127.00	254.00	558.80	203.20	100.08	122.17	165.10	1.52	M8 x 12DP	17.53	38.10	1/2 NPT	80		
4.5 - 9.0 cc/rev 1 HP with Reducer	110 in-lb	30.00	5.28	3.44	5.94	11.70	5.00	10.00	28.00	8.00	3.94	5.25	6.50	0.17	M8 x 12DP	0.69	1.50	1/2 NPT	56-C	
	762.00	134.11	87.38	150.88	297.18	127.00	254.00	711.20	203.20	100.08	133.35	165.10	4.32	M8 x 12DP	17.53	38.10	1/2 NPT	80		
4.5 - 9.0 cc/rev 2 HP Direct Drive	110 in-lb	24.00	4.84	4.00	5.47	11.20	5.00	10.00	22.00	8.00	3.94	4.81	6.50	3.36	M8 x 12DP	0.69	1.50	1/2 NPT	140TC	
	609.60	122.94	101.60	138.94	284.48	127.00	254.00	558.80	203.20	100.08	122.17	165.10	85.34	M8 x 12DP	17.53	38.10	1/2 NPT	9		
4.5 - 9.0 cc/rev 2 HP with Reducer	110 in-lb	30.00	5.28	3.44	5.94	11.70	5.00	10.00	28.00	8.00	3.94	5.25	6.50	2.77	M8 x 12DP	0.69	1.50	1/2 NPT	140TC	
	762.00	134.11	87.38	150.88	297.18	127.00	254.00	711.20	203.20	100.08	133.35	165.10	70.36	M8 x 12DP	17.53	38.10	1/2 NPT	9		

1) Select Pump Model

		B-9000	C-9000	H-9000
Typical Service	General Chemical	✓	—	—
	Corrosive/Poor Lubricity	—	✓	—
Materials	Abrasive/High Temperature	—	—	✓
	400 Series Stainless Steel	✓	—	—
	316 Stainless Steel	—	✓	—
Outlet Pressure	Tool Steel	—	—	✓
	≤ 1000 psi	✓	✓	✓
Inlet Pressure	1000 ≤ 2500 psi	—	—	✓
	≤ 300 psi	✓	✓	✓
Temperature	300 ≤ 1000 psi	—	—	✓
	≤ 350 F	✓	✓	✓
	≤ 645 F	✓	—	✓
Viscosity	≤ 950 F	—	—	✓
	≤ 1 cps	—	✓	—
Flow Rate	≥ 1 cps	✓	✓	✓
	≤ 9000 cc/min	✓	✓	✓
Lubricity	≤ 27000 cc/min	✓	—	✓
	Abrasive (TiO ₂ etc.)	—	—	✓
	Poor (Solvents etc.)	—	✓	—
pH	Good (Polyols etc.)	✓	✓	✓
	Excellent (Oils etc.)	✓	✓	✓
	Low (< 7)	—	✓	—
	Neutral (7)	✓	✓	✓
	High (> 7)	✓	✓	—

2) Select Maximum Operating Speed

Operating Conditions		Suggested Maximum Speed (RPM)		
Lubricity	Viscosity	B-9000	C-9000	H-9000
Excellent	< 1,000 cps	< 500	< 1000	< 500
Good to Excellent	1000 < 10,000 cps	< 300	< 500	< 300
Poor to Excellent	> 10,000 cps	< 150	< 150	< 150
Abrasive (Consult Zenith)	> 1 cps	—	—	< 75

3) Select Pump Size

- 1) Maximum Flow (cc/min) ÷ Maximum Operating Speed = Pump Capacity (cc/rev).
- 2) Round up to the next largest pump size. See page 3 for available sizes.
- 3) Calculate Minimum Operating Speed (rpm) = Minimum Flow (cc/min) ÷ Pump Capacity (cc/rev).

4) Select Reducer Ratio (All Systems) or Direct Drive (Magnetic Drive Systems Only)

Select a reducer ratio and speed range that best fits the maximum and minimum operating speeds calculated in steps 2 and 3.

Pump Speed Range with 1800 rpm Motor, 20:1 Turndown						
Speed Range (n - N)	90 - 1800*	50 - 1000	30 - 600	18 - 360	8 - 164	4 - 82
Reducer Ratio	1:1 (Direct)	1.8:1	3:1	5:1	11:1	22:1

* **Note:** maximum recommended pump speed is 1000 rpm or less.

5) Calculate Maximum Pump Torque Requirements

- 1) Pump Torque: T (in-lbs) = $(K_1 \cdot \Delta P \text{ (psi)}) + (K_2 \cdot N \cdot \mu / 100,000)$ or
 T (Nm) = $(K_3 \cdot \Delta P \text{ (kg/cm}^2\text{)}) + (K_4 \cdot N \cdot \mu / 100,000)$

K_1, K_2, K_3 & K_4 = Constants from adjacent chart

ΔP = Differential Pressure (Outlet Pressure – Inlet Pressure)

N = Maximum Pump Speed, based on Reducer Ratio. See step 4.

μ = Viscosity (cps). **Note:** for shear thinning fluids, consult Zenith.

- 2) Compare the calculated torque to the maximum torque shown in the adjacent chart. The calculated torque must not exceed the maximum torque.
- 3) For magnetic drive systems, the calculated torque cannot exceed the maximum torque rating of the magnetic coupling. See page 5 for torque limits and available system configurations.

Capacity (cc/rev)	K_1/K_2	K_3/K_4	Max. Torque (in-lbs/NM)
0.05	0.0005/0.85	0.0008/0.096	7.5/.85
0.3	0.003/2.11	0.004/0.24	90/10
0.6	0.006/2.34	0.010/0.26	350/40
1.2	0.012/2.82	0.018/0.32	350/40
2.4	0.023/3.78	0.037/0.43	350/40
4.5	0.044/6.85	0.070/0.77	880/100
9.0	0.087/8.56	0.141/0.97	880/100
15.0	0.146/14.66	0.233/1.66	1100/125
30.0	0.291/18.57	0.468/2.10	1100/125
45.0	0.437/32.78	0.701/3.70	2400/275
90.0	0.873/30.61	1.404/3.46	2400/275

6) Calculate System HP

$$1) \text{ HP} = T / (35 \cdot .85 \cdot R)$$

T = Maximum Torque (in-lbs) from Step 5

R = Reducer Ratio from Step 4 (For example, if 3:1 use 3)

$$\text{or } \text{KW} = T / (5.3 \cdot .85 \cdot R)$$

T = Maximum Torque (Nm) from Step 5

R = Reducer Ratio from Step 4 (for example, if 3:1 use 3)

- 2) Round up to the next highest motor horsepower available i.e. calculated HP = .33, select 1/2 HP motor. See page 4 for standard system configurations available based on pump size and horsepower.

7) Check Pump Efficiency

Based on application conditions, verify that the efficiency of the pump is acceptable. For high pressure and low viscosity applications, it may be necessary to increase pump speed or pump capacity. Contact Zenith for assistance.

- 1) Use the formula shown below the X-axis to calculate a value.
- 2) Using the value calculated, trace a line vertically until the appropriate pump curve is intersected.
- 3) Trace a line horizontally to the left to obtain a value for the derating factor.
- 4) Multiply the derating factor by the theoretical flow, N (rpm) • Pump Size (cc/rev), to obtain estimated actual flow (cc/min).

8) Check Inlet Pressure Requirements

In order to prevent cavitation and ensure successful operation, sufficient inlet pressure must be available at the inlet of the pump. Based on maximum application conditions, verify that the inlet pressure available exceeds the inlet pressure loss.

$$\text{Inlet Pressure Loss (psi)} = \text{Viscosity(cps)} \cdot \text{Displacement(cc/rev)} \cdot \text{Shaft Speed(rpm)} \cdot [(\text{Specific Gravity} \cdot W1) + W2]$$

cc/rev	W1	W2
0.3	4.29E-06	2.32E-06
0.6	1.93E-06	2.47E-06
1.2	1.21E-06	2.77E-06
2.4	9.34E-07	3.38E-06
4.5	3.00E-07	3.46E-07
9.0	2.24E-07	4.19E-07
15.0	1.11E-07	7.47E-08
30.0	8.61E-08	9.28E-08
45.0	3.38E-08	1.65E-08
90.0	2.49E-08	2.02E-08

Note: This sizing procedure should be used as a guideline for estimating pump type, pump size and system requirements. Please consult Zenith to confirm pump and system selection prior to placing a purchase order.

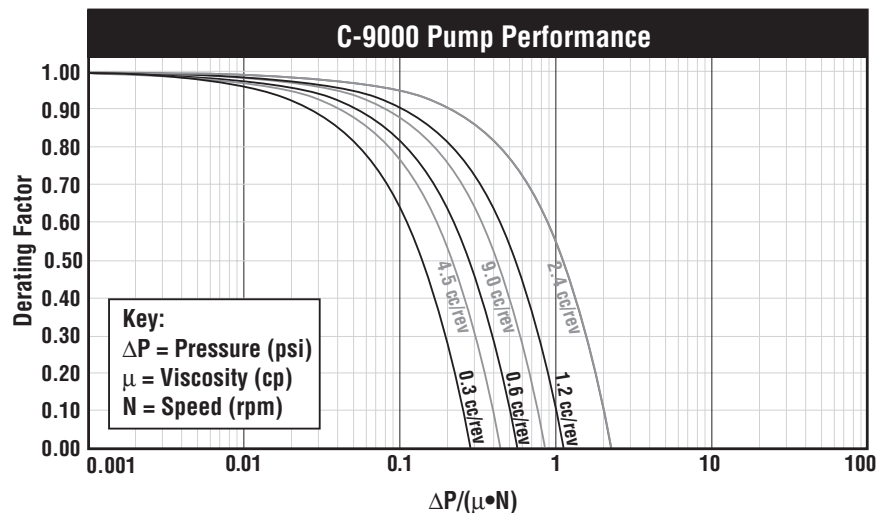
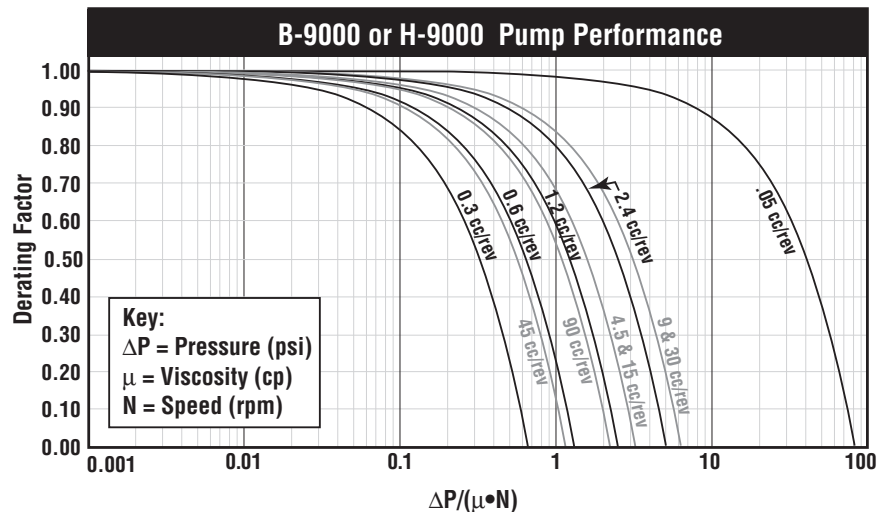

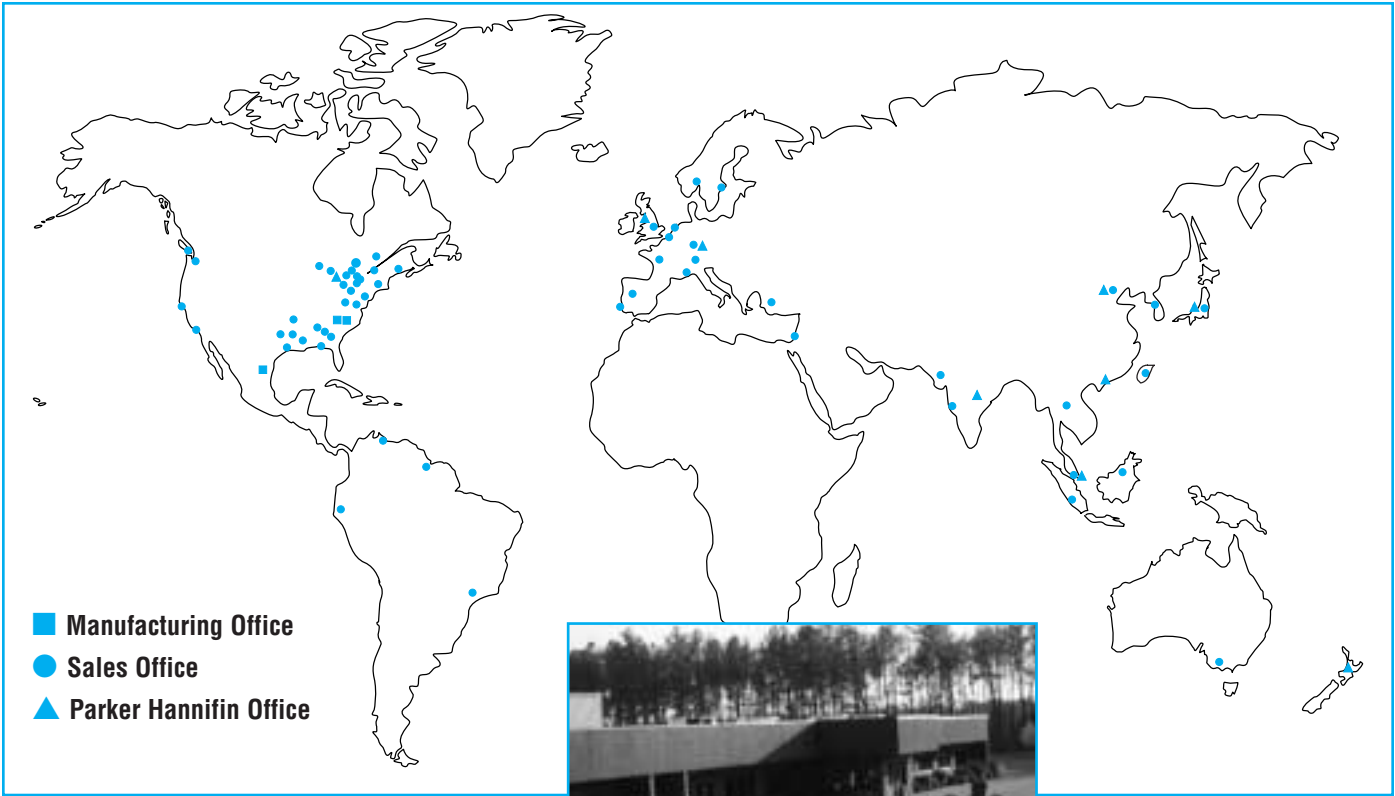

Sanford, NC



Aberdeen, NC



Monterrey, Mexico



Warwick England



WARNING

FAILURE, IMPROPER SELECTION OR IMPROPER USE OF THE PRODUCTS AND/OR SYSTEMS DESCRIBED HEREIN OR RELATED ITEMS CAN CAUSE DEATH, PERSONAL INJURY AND PROPERTY DAMAGE.

This document and other information from Parker Hannifin Corporation, its subsidiaries and authorized distributors provide product and/or system options for further investigation by users having technical expertise. It is important that you analyze all aspects of your application and review the information concerning the product or system in the current product catalog. Due to the variety of operating conditions and applications for these products or systems, the user, through its own analysis and testing, is solely responsible for making the final selection of the products and systems and assuring that all performance, safety and warning requirements of the application are met.

The products described herein, including without limitation, product features, specifications, designs, availability and pricing, are subject to change by Parker Hannifin Corporation and its subsidiaries at any time without notice.

Parker Hannifin Corporation

Zenith® Pumps
 5910 Elwin Buchanan Drive
 Sanford, NC 27330-9551 USA
 Phone: 919-774-7667 • Fax: 919-774-5952
 www.zenithpumps.com • e-mail: zenithpumps@parker.com

anything **Parker**
Possible.™



Certificate QSR-065

