

# Husky<sup>®</sup> 1050 Air-Operated Diaphragm Pump

312877A

**1-inch pump with modular air valve for fluid transfer applications**

125 psi (0.86 MPa, 8.6 bar) Maximum Fluid Working Pressure

125 psi (0.86 MPa, 8.6 bar) Maximum Air Input Pressure



### Important Safety Instructions

Read all warnings and instructions in this manual. Save these instructions.

See page 3 for model information, including approvals.

**1050P Polypropylene**  
**1050C Conductive Polypropylene**

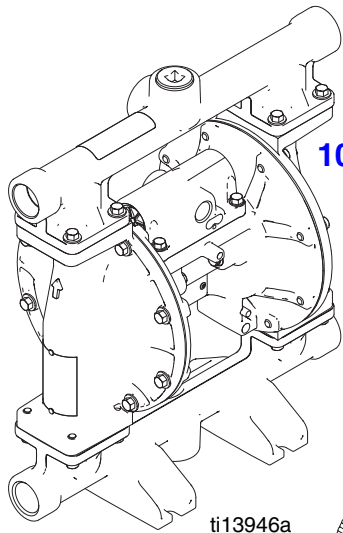

**1050A Aluminum**

ti13946a

with End Flange

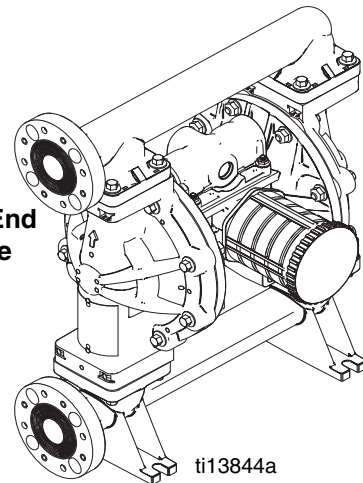

ti13844a

**1050S Stainless Steel**

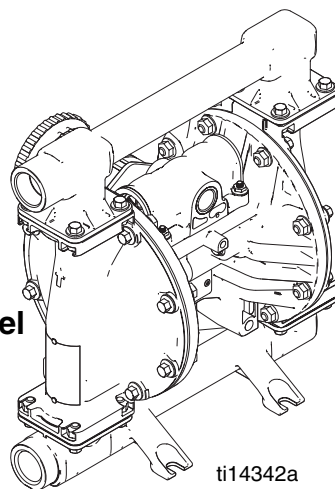

ti14342a

with Center Flange

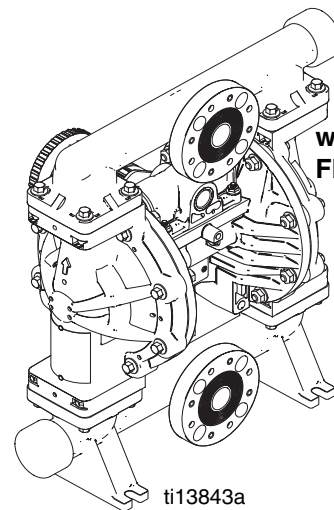

ti13843a



# Contents

<b>Related Manuals</b> .....	<b>2</b>	<b>Operation</b> .....	<b>14</b>
<b>Pump Matrix</b> .....	<b>3</b>	Pressure Relief Procedure .....	14
ATEX Certifications .....	3	Flush the Pump Before First Use .....	14
<b>Warnings</b> .....	<b>4</b>	Tighten Fasteners Before Setup .....	14
<b>Installation</b> .....	<b>6</b>	Starting and Adjusting the Pump .....	14
Tighten Fasteners Before Setup .....	6	DataTrak Operation .....	15
Mounting .....	6	Pump Shutdown .....	15
Grounding .....	7	<b>Maintenance</b> .....	<b>15</b>
Air Line .....	8	Maintenance Schedule .....	15
Reed Switch .....	8	Lubrication .....	15
Air Exhaust Ventilation .....	8	Flushing and Storage .....	15
Fluid Supply Line .....	9	Torque Instructions .....	16
Fluid Outlet Line .....	9	<b>Dimensions and Mounting</b> .....	<b>18</b>
Fluid Inlet and Outlet Ports .....	12	Aluminum (1050A) .....	18
Fluid Pressure Relief Valve .....	13	Polypropylene (1050P) and Conductive Polypropylene (1050C) .....	19
		Stainless Steel (1050S) .....	20
		<b>Performance Charts</b> .....	<b>21</b>
		<b>Technical Data</b> .....	<b>22</b>
		<b>Graco Standard Warranty</b> .....	<b>24</b>
		<b>Graco Information</b> .....	<b>24</b>

## Related Manuals

Manual	Description
<b>313435</b>	Husky 1050 Air-Operated Diaphragm Pump, Repair/Parts
<b>313597</b>	Husky 1050A UL-Listed Diaphragm Pump, Operation
<b>313598</b>	Husky 1050A CSA-Certified Diaphragm Pump, Operation
<b>313840</b>	DataTrak, Instructions/Parts
<b>406824</b>	Pulse Count Kits, Instructions

# Pump Matrix

Check the identification plate (ID) for the 20-digit part number of your pump. Use the following matrix to define the components of your pump. For example, pump number **1050A-A01AA1SSBNBNPT** represents a Husky 1 inch, 50 gpm aluminum pump (**1050A**), with aluminum center section (**A01**), a standard air valve (**A**), aluminum fluid covers (**A**) and manifolds with standard ports in inches (**1**). The pump has stainless steel seats (**SS**), buna-N check balls (**BN**), buna-N diaphragms (**BN**), and PTFE manifold o-rings (**PT**).

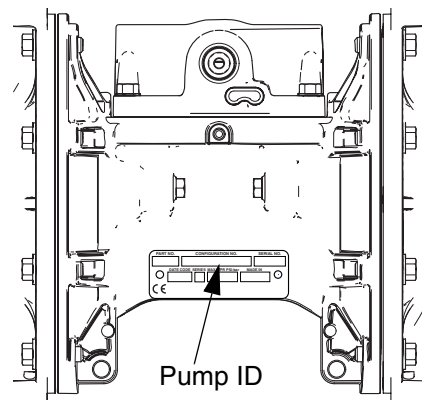

ti14103a

**NOTE:** Options for seats, check balls, diaphragms, and seals vary for the 1050A, 1050C, 1050P, and 1050S pump models. To build a pump, use the selector tool at [www.graco.com](http://www.graco.com) or speak with your distributor.

Pump (1 inch ports, 50 gpm)	Center Section and Air Valve Material	Air Valve/Monitoring	Fluid Covers and Manifolds
<b>1050A</b> ★ Aluminum	Aluminum	<b>A01A</b> Standard	<b>A1</b> Aluminum, standard ports, inch
		<b>A01B</b> Pulse Count✳	<b>A2</b> Aluminum, standard ports, metric
		<b>A01C</b> DataTrak✳	<b>C1</b> Conductive polypropylene, center flange
<b>1050C</b> ★ Conductive Polypropylene	Conductive Polypropylene	<b>C01A</b> Standard	<b>C2</b> Conductive polypropylene, end flange
		<b>C01B</b> Pulse Count✳	<b>P1</b> Polypropylene, center flange
		<b>C01C</b> DataTrak✳	<b>P2</b> Polypropylene, end flange
<b>1050P</b> Polypropylene	Polypropylene	<b>P01A</b> Standard	<b>S1</b> Stainless steel, standard ports, inch
<b>1050S</b> ‡ Stainless Steel		<b>P01B</b> Pulse Count✳	<b>S2</b> Stainless steel, standard ports, metric
		<b>P01C</b> DataTrak✳	
★, ‡, or ✳: See <b>ATEX Certifications</b> below.			

Check Valve Seats		Check Valve Balls		Diaphragm		Manifold O-Rings	
<b>AC</b> Acetal	<b>AC</b> Acetal	<b>BN</b> Buna-N	<b>BN</b> Buna-N	<b>CO</b> Polychloroprene Overmolded	<b>CO</b> Polychloroprene Overmolded	<b>—</b> None	<b>—</b> None
<b>AL</b> Aluminum	<b>BN</b> Buna-N	<b>CR</b> Polychloroprene Standard	<b>CR</b> Polychloroprene Standard	<b>FK</b> FKM Fluoroelastomer	<b>FK</b> FKM Fluoroelastomer	<b>PT</b> PTFE	<b>PT</b> PTFE
<b>BN</b> Buna-N	<b>CW</b> Polychloroprene Weighted	<b>GE</b> Geolast	<b>GE</b> Geolast	<b>PO</b> PTFE/EPDM Overmolded	<b>PO</b> PTFE/EPDM Overmolded		
<b>FK</b> FKM Fluoroelastomer	<b>FK</b> FKM Fluoroelastomer	<b>PT</b> PTFE/EPDM Two-Piece	<b>PT</b> PTFE/EPDM Two-Piece	<b>SP</b> Santoprene	<b>SP</b> Santoprene		
<b>GE</b> Geolast®	<b>PT</b> PTFE	<b>TP</b> TPE	<b>TP</b> TPE				
<b>PP</b> Polypropylene	<b>SP</b> Santoprene						
<b>PV</b> PVDF	<b>SS</b> 316 Stainless Steel						
<b>SP</b> Santoprene®	<b>TP</b> TPE						
<b>SS</b> 316 Stainless Steel							
<b>TP</b> TPE							

## ATEX Certifications

★ All **1050A** (Aluminum) and **1050C** (Conductive Polypropylene) pumps are certified:

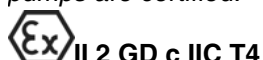

‡ **1050S** (Stainless Steel) pumps with aluminum or conductive polypropylene centers are certified:



✳ DataTrak and Pulse Count are certified:

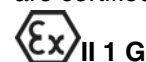

EEx ia IIA T3  
Nemko  
06ATEX1124

# Warnings

The following warnings are for the setup, use, grounding, maintenance, and repair of this equipment. The exclamation point symbol alerts you to a general warning and the hazard symbol refers to procedure-specific risk. Refer back to these warnings. Additional, product-specific warnings may be found throughout the body of this manual where applicable.

## WARNING



### FIRE AND EXPLOSION HAZARD

Flammable fumes, such as solvent and paint fumes, in **work area** can ignite or explode. To help prevent fire and explosion:

- Use equipment only in well ventilated area.
- Eliminate all ignition sources; such as pilot lights, cigarettes, portable electric lamps, and plastic drop cloths (potential static arc).
- Keep work area free of debris, including solvent, rags and gasoline.
- Do not plug or unplug power cords, or turn power or light switches on or off when flammable fumes are present.
- Ground all equipment in the work area. See **Grounding** instructions.
- Use only grounded hoses.
- Hold gun firmly to side of grounded pail when triggering into pail.
- If there is static sparking or you feel a shock, **stop operation immediately**. Do not use equipment until you identify and correct the problem.
- Keep a working fire extinguisher in the work area.

Static charge may build up on plastic parts during cleaning and could discharge and ignite flammable materials and gases. To help prevent fire and explosion:

- Clean plastic parts in a well ventilated area.
- Do not clean with a dry cloth.



## WARNING



### EQUIPMENT MISUSE HAZARD

Misuse can cause death or serious injury.

- Do not operate the unit when fatigued or under the influence of drugs or alcohol.
- Do not exceed the maximum working pressure or temperature rating of the lowest rated system component. See **Technical Data** in all equipment manuals.
- Use fluids and solvents that are compatible with equipment wetted parts. See **Technical Data** in all equipment manuals. Read fluid and solvent manufacturer's warnings. For complete information about your material, request MSDS from distributor or retailer.
- Do not leave the work area while equipment is energized or under pressure. Turn off all equipment and follow the **Pressure Relief Procedure** in this manual when equipment is not in use.
- Check equipment daily. Repair or replace worn or damaged parts immediately with genuine manufacturer's replacement parts only.
- Do not alter or modify equipment.
- Use equipment only for its intended purpose. Call your distributor for information.
- Route hoses and cables away from traffic areas, sharp edges, moving parts, and hot surfaces.
- Do not kink or over bend hoses or use hoses to pull equipment.
- Keep children and animals away from work area.
- Comply with all applicable safety regulations.



### PRESSURIZED EQUIPMENT HAZARD

Fluid from the gun/dispense valve, leaks, or ruptured components can splash in the eyes or on skin and cause serious injury.

- Follow **Pressure Relief Procedure** in this manual, when you stop spraying and before cleaning, checking, or servicing equipment.
- Tighten all fluid connections before operating the equipment.
- Check hoses, tubes, and couplings daily. Replace worn or damaged parts immediately.



### PRESSURIZED ALUMINUM PARTS HAZARD





Use of fluids that are incompatible with aluminum in pressurized equipment can cause serious chemical reaction and equipment rupture. Failure to follow this warning can result in death, serious injury, or property damage.

- Do not use 1,1,1-trichloroethane, methylene chloride, other halogenated hydrocarbon solvents or fluids containing such solvents.
- Many other fluids may contain chemicals that can react with aluminum. Contact your material supplier for compatibility.



### PLASTIC PARTS CLEANING SOLVENT HAZARD

Use only compatible water-based solvents to clean plastic structural or pressure-containing parts. Many solvents can degrade plastic parts and cause them to fail, which could cause serious injury or property damage. See **Technical Data** in this and all other equipment instruction manuals. Read fluid and solvent manufacturer's warnings.

 <b>WARNING</b>	
	<p><b>TOXIC FLUID OR FUMES HAZARD</b></p> <p>Toxic fluids or fumes can cause serious injury or death if splashed in the eyes or on skin, inhaled, or swallowed.</p> <ul style="list-style-type: none"> <li>• Read MSDS's to know the specific hazards of the fluids you are using.</li> <li>• Route exhaust away from work area. If diaphragm ruptures, fluid may be exhausted with air.</li> <li>• Store hazardous fluid in approved containers, and dispose of it according to applicable guidelines.</li> <li>• Always wear impervious gloves when spraying or cleaning equipment.</li> </ul>
	<p><b>BURN HAZARD</b></p> <p>Equipment surfaces and fluid that's heated can become very hot during operation. To avoid severe burns:</p> <ul style="list-style-type: none"> <li>• Do not touch hot fluid or equipment.</li> <li>• Wait until equipment/fluid has cooled completely.</li> </ul>
	<p><b>PERSONAL PROTECTIVE EQUIPMENT</b></p> <p>You must wear appropriate protective equipment when operating, servicing, or when in the operating area of the equipment to help protect you from serious injury, including eye injury, inhalation of toxic fumes, burns, and hearing loss. This equipment includes but is not limited to:</p> <ul style="list-style-type: none"> <li>• Clothing and respirator as recommended by the fluid and solvent manufacturer</li> <li>• Protective eyewear, gloves, and hearing protection</li> </ul>

## Installation

The Typical Installations shown in FIG. 3 and FIG. 4 are only guides for selecting and installing system components. Contact your Graco distributor for assistance in planning a system to suit your needs.

## Tighten Fasteners Before Setup

Before using the pump for the first time, check and retorque all external fasteners. Follow **Torque Instructions**, page 16.

## Mounting



- The pump exhaust air may contain contaminants. Ventilate to a remote area. See **Air Exhaust Ventilation** on page **8**.
- Never move or lift a pump under pressure. If dropped, the fluid section may rupture. Always follow the **Pressure Relief Procedure** on page **14** before moving or lifting the pump.

1. Be sure the mounting surface can support the weight of the pump, hoses, and accessories, as well as the stress caused during operation.
2. For all mountings, be sure the pump is bolted directly to the mounting surface.
3. For ease of operation and service, mount the pump so air valve, air inlet, fluid inlet and fluid outlet ports are easily accessible.
4. Rubber Foot Mounting Kit 236452 is available to reduce noise and vibration during operation.

## Grounding

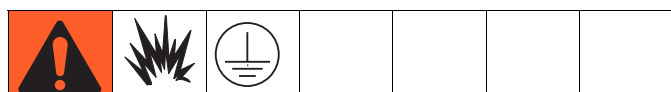

The equipment must be grounded. Grounding reduces the risk of static and electric shock by providing an escape wire for the electrical current due to static build up or in the event of a short circuit.

**Pump:** See FIG. 1. Loosen the grounding screw (GS). Insert one end of a 12 ga. minimum ground wire (R) behind the grounding screw and tighten the screw securely. Connect the clamp end of the ground

wire to a true earth ground. A ground wire and clamp, Part 238909, is available from Graco.

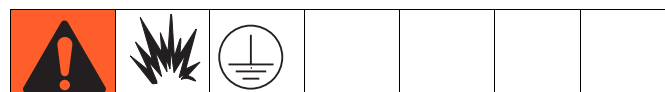

**Polypropylene:** Only conductive polypropylene pumps have a ground screw. Standard polypropylene pumps are **not** conductive. **Never** use a non-conductive polypropylene pump with non-conductive flammable fluids. Follow your local fire codes. When pumping conductive flammable fluids, **always** ground the entire fluid system as described.

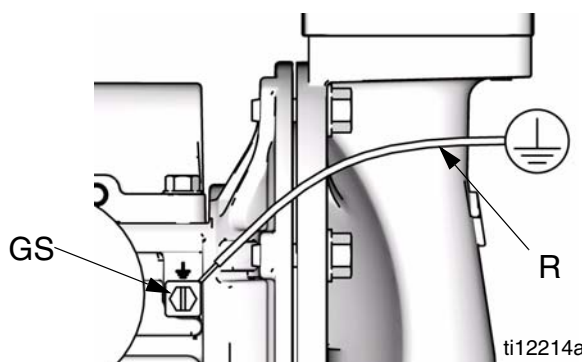

**FIG. 1. Grounding screw and wire**

**Air and fluid hoses:** Use only grounded hoses with a maximum of 500 ft (150 m) combined hose length to ensure grounding continuity.

**Air compressor:** Follow manufacturer's recommendations.

**Fluid supply container:** Follow local code.

**Solvent pails used when flushing:** Follow local code. Use only conductive metal pails, placed on a grounded surface. Do not place the pail on a nonconductive surface, such as paper or cardboard, which interrupts grounding continuity.

Check your system electrical continuity after the initial installation, and then set up a regular schedule for checking continuity to be sure proper grounding is maintained.

## Air Line

See FIG. 3 and FIG. 4, pages 10 and 11.

1. Install an air regulator (C) and gauge to control the fluid pressure. The fluid stall pressure will be the same as the setting of the air regulator.
2. Locate a bleed-type master air valve (B) close to the pump and use it to relieve trapped air. Be sure the valve is easily accessible from the pump and located downstream from the regulator.

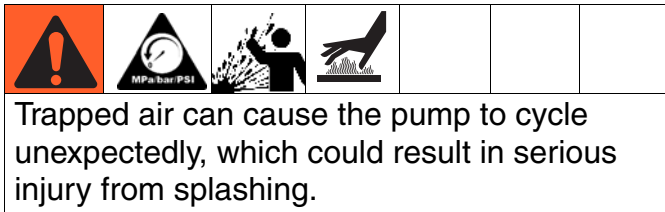

3. Locate another master air valve (E) upstream from all air line accessories and use it to isolate them during cleaning and repair.
4. An air line filter (F) removes harmful dirt and moisture from the compressed air supply.
5. Install a grounded, flexible air hose (A) between the accessories and the 1/2 npt(f) pump air inlet (D). Use a minimum 3/8 in. (10 mm) ID air hose.

## Reed Switch

Pulse Count models are intended for use with customer-supplied fluid management or inventory tracking systems. Attach an M12, 5-pin female cable to connect the reed switch to your data monitoring system. *See Manual 406824.*

## Air Exhaust Ventilation



The air exhaust port is 3/4 npt(f). Do not restrict the air exhaust port. Excessive exhaust restriction can cause erratic pump operation.

To provide a remote exhaust:

1. Remove the muffler (T) from the pump air exhaust port.
2. Install a grounded air exhaust hose (U) and connect the muffler (T) to the other end of the hose. The minimum size for the air exhaust hose is 3/4 in. (19 mm) ID. If a hose longer than 15 ft (4.57 m) is required, use a larger diameter hose. Avoid sharp bends or kinks in the hose.
3. Place a container at the end of the air exhaust line to catch fluid in case a diaphragm ruptures. If the diaphragm ruptures, the fluid being pumped will exhaust with the air.



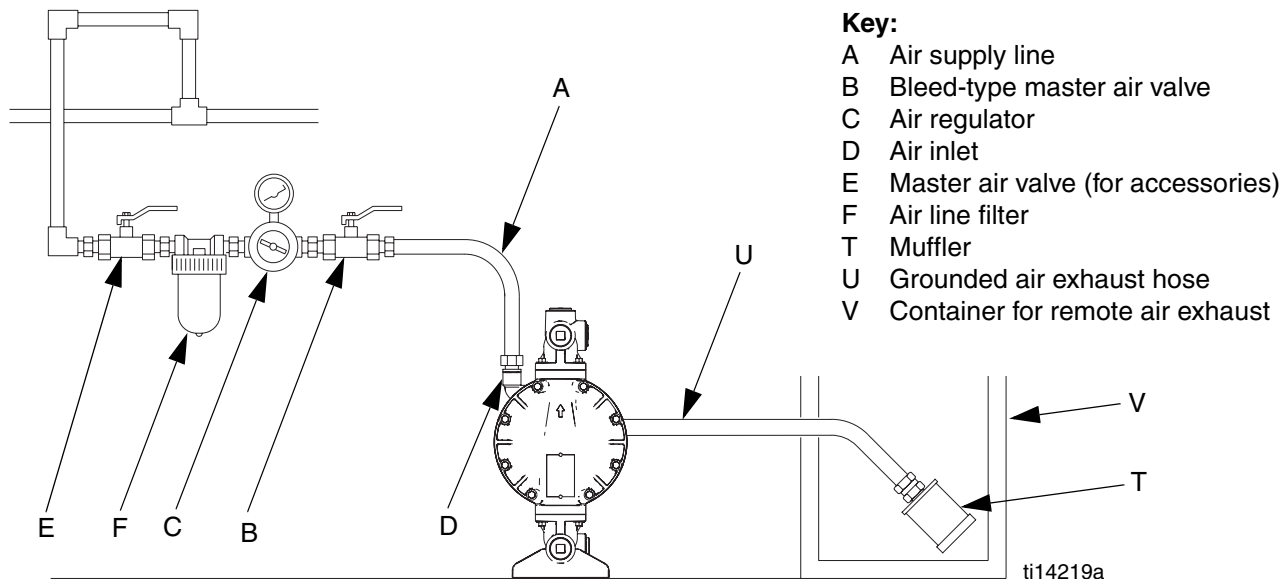

**FIG. 2. Vent exhaust air**

## Fluid Supply Line

See FIG. 3 and FIG. 4, pages 10 and 11.

1. Use grounded fluid supply lines (G). See **Grounding**, page 7.
2. If the inlet fluid pressure to the pump is more than 25% of the outlet working pressure, the ball check valves will not close fast enough, resulting in inefficient pump operation.
3. At inlet fluid pressures greater than 15 psi (0.1 MPa, 1 bar), diaphragm life will be shortened.
4. For maximum suction lift (wet and dry), see **Technical Data**, page 22.

## Fluid Outlet Line

See FIG. 3 and FIG. 4, pages 10 and 11.

1. Use grounded fluid hoses (L). See **Grounding**, page 7.
2. Install a fluid drain valve (J) near the fluid outlet.
3. Install a shutoff valve (K) in the fluid outlet line.

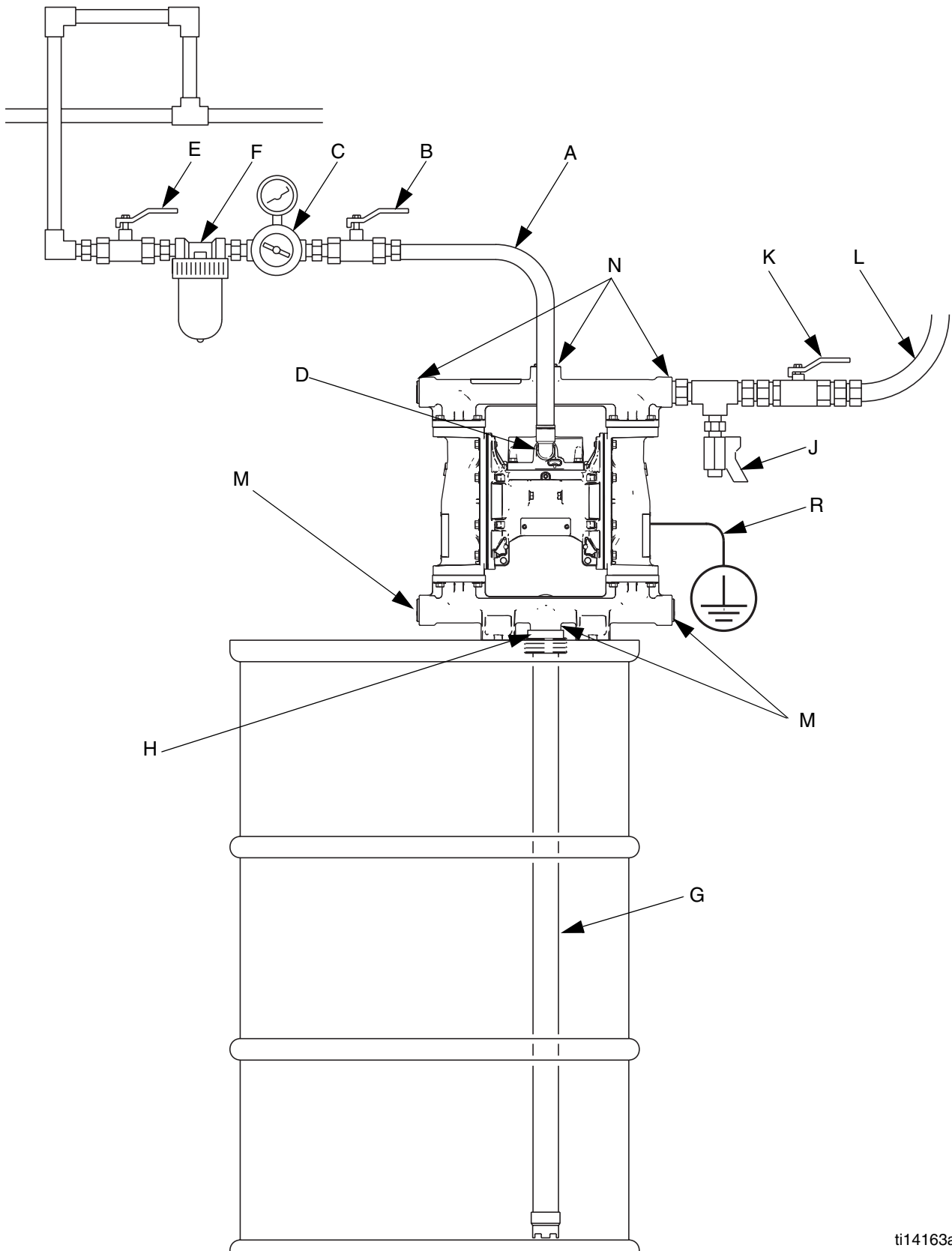

ti14163a

**Fig. 3. Typical bung-mount installation (aluminum, 1050A, pump shown)**

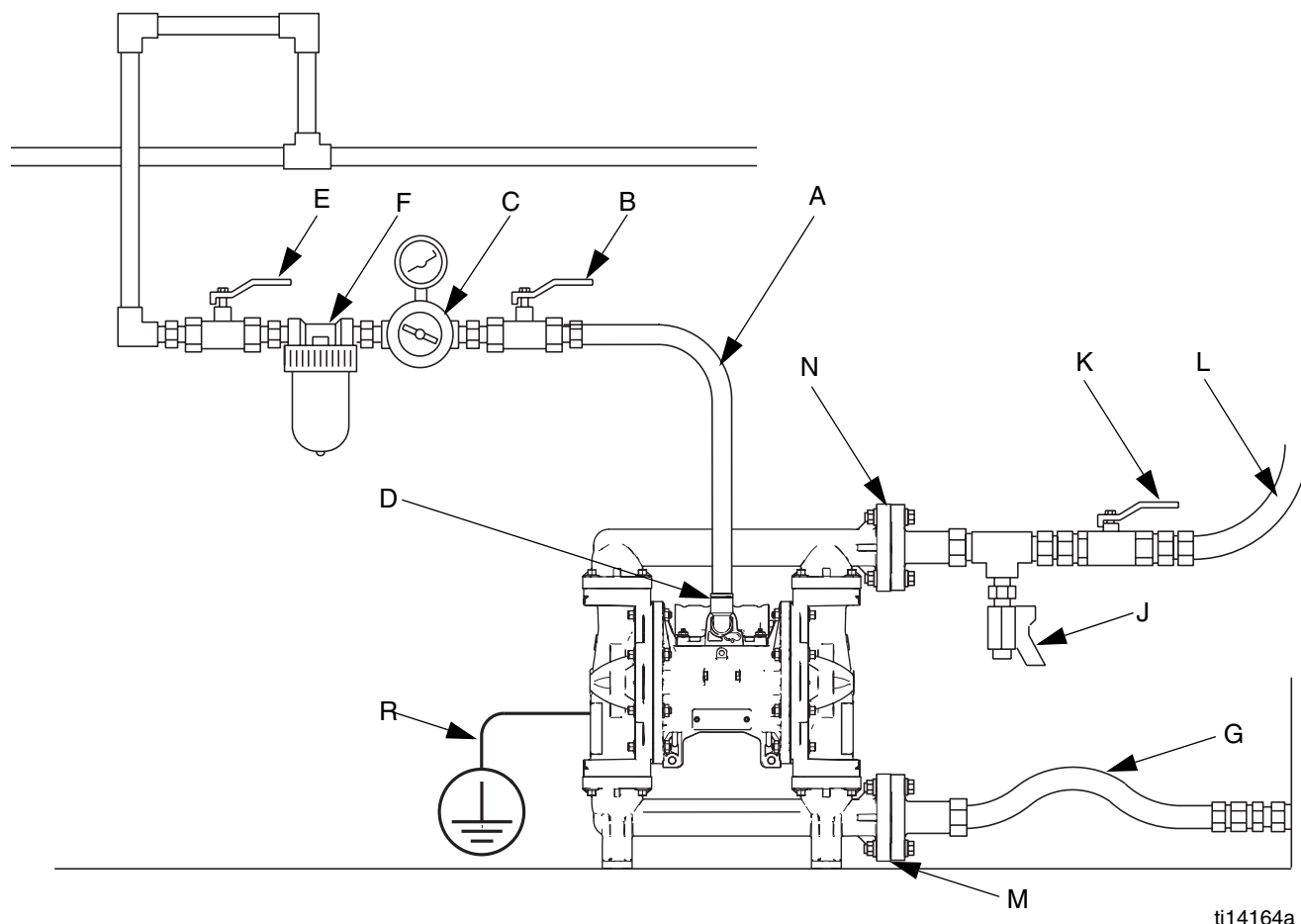

**FIG. 4. Typical floor-mount installation (polypropylene, 1050P, pump shown)**

**Key for FIG. 3 and FIG. 4:**

- A Air supply line
- B Bleed-type master air valve (required for pump)
- C Air regulator
- D Air inlet
- E Master air valve (for accessories)
- F Air line filter
- G Fluid suction line
- H Bung adapter
- J Fluid drain valve (required)
- K Fluid shutoff valve
- L Fluid line
- M Fluid inlet (Aluminum, FIG. 3, four ports, one not visible; Plastic, FIG. 4, center or end flanges available; Stainless Steel, not pictured, one port)

- N Fluid outlet (Aluminum, FIG. 3, four ports, one not visible; Plastic, FIG. 4, center or end flanges available; Stainless Steel, not pictured, one port)
- R Ground wire (required for aluminum, conductive polypropylene, and stainless steel pumps; see page 7 for installation instructions)

## Fluid Inlet and Outlet Ports

**NOTE:** Remove and reverse the manifold(s) to change the orientation of inlet or outlet port(s). Follow **Torque Instructions** on page 16.

### Aluminum (1050A)

The fluid inlet and outlet manifolds each have four 1 in. npt(f) or bspt threaded ports (FIG. 3, M, N). Close off the unused ports, using the supplied plugs.

### Plastic (1050P, 1050C)

The fluid inlet and outlet manifolds each have a 1 in. raised face ANSI/DIN flange (FIG. 4, M, N) in either a center or end location. Connect 1 in. standard flanged plastic pipe to the pump. See FIG. 5.

Graco standard pipe flange kits are available in polypropylene (239005), stainless steel (239008), and PVDF (239009). These kits include:

- the pipe flange
- a PTFE gasket
- four 1/2 in. bolts, spring lock washers, flat washers and nuts.

Be sure to lubricate the threads of the bolts and torque to 10-15 ft-lb (14-20 N•m). Follow the bolt tightening sequence and **do not over-torque**.

### Stainless Steel (1050S)

The fluid inlet and outlet manifolds each have one 1 in. npt (f) or bspt threaded port.

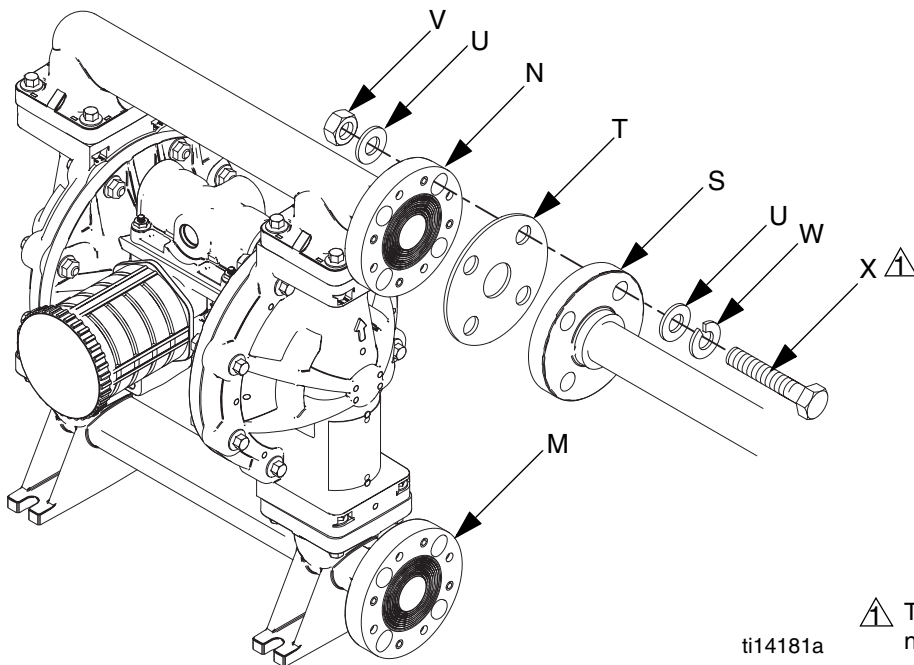

### Bolt tightening sequence

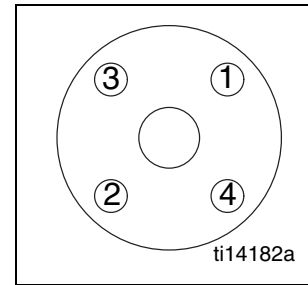

### Key:

- M 1 in. fluid inlet flange
- N 1 in. fluid outlet flange
- S 1 in. standard pipe flange
- T PTFE gasket
- U Flat washer
- V Nut
- W Lock washer
- X Bolt

 Torque to 10-15 ft-lb (14-20 N•m). Do not over-torque.

ti14181a

**FIG. 5. Flange connections (plastic pumps only, 1050P and 1050C models)**

## Fluid Pressure Relief Valve



Some systems may require installation of a pressure relief valve at the pump outlet to prevent overpressurization and rupture of the pump or hose.

Thermal expansion of fluid in the outlet line can cause overpressurization. Thermal expansion can occur when using long fluid lines exposed to sunlight or ambient heat, or when pumping from a cool to a warm area (for example, from an underground tank).

Overpressurization also can occur if the Husky pump is used to feed fluid to a piston pump, and the intake valve of the piston pump does not close, causing fluid to back up in the outlet line.

FIG. 6 shows Fluid Pressure Relief Kit 238428 for aluminum pumps. Use Fluid Pressure Relief Kit 112119, not shown, for plastic pumps.

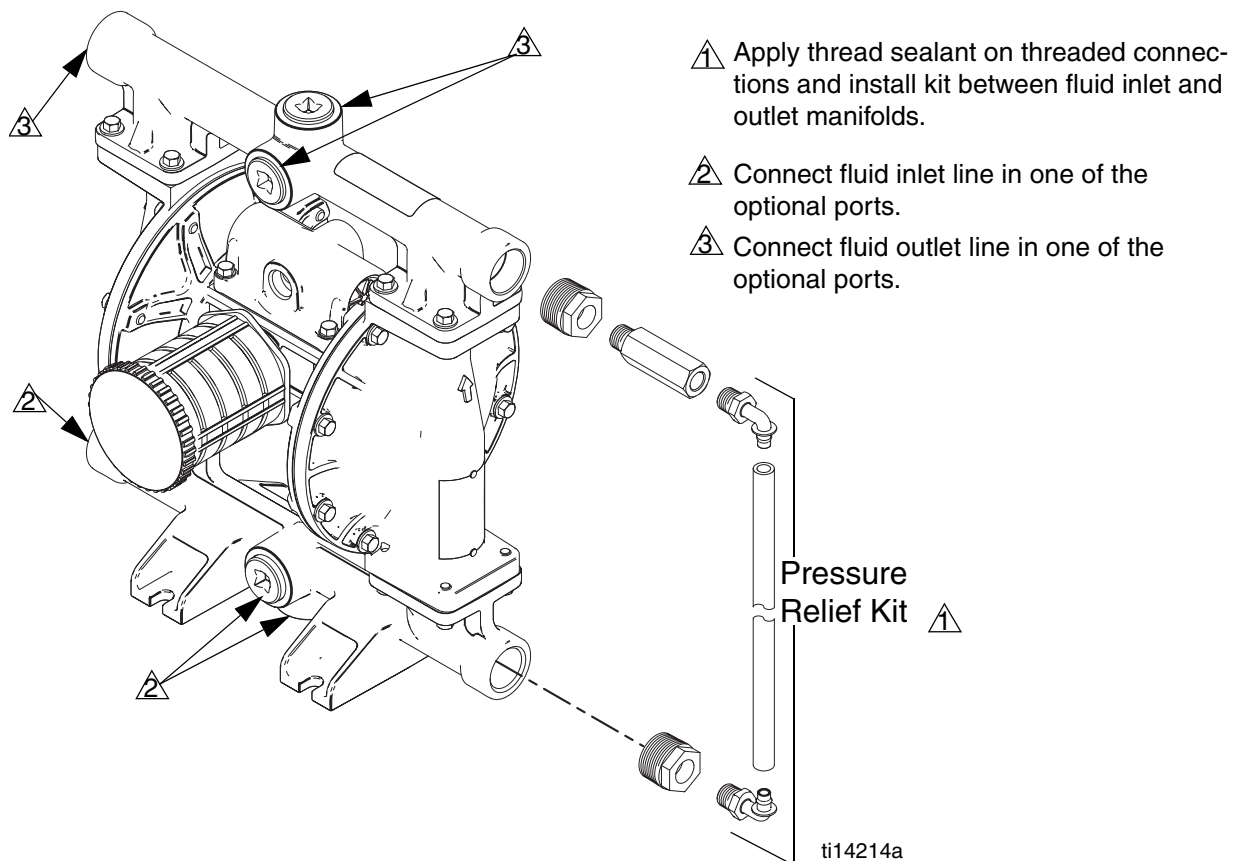

**FIG. 6. Fluid pressure relief kit (Aluminum pumps only, 1050A models)**

# Operation

## Pressure Relief Procedure

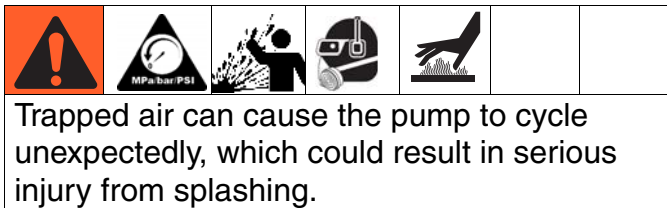

1. Shut off the air supply to the pump.
2. Open the dispensing valve, if used.
3. Open the fluid drain valve to relieve fluid pressure. Have a container ready to catch the drainage.

## Flush the Pump Before First Use

The pump was tested in water. If water could contaminate the fluid you are pumping, flush the pump thoroughly with a compatible solvent. See **Flushing and Storage**, page 15.

## Tighten Fasteners Before Setup

Before using the pump for the first time, check and retorque all external fasteners. Follow **Torque Instructions**, page 16. After the first day of operation, retorque the fasteners.

## Starting and Adjusting the Pump

1. Be sure the pump is properly grounded. Refer to **Grounding** on page 7.
2. Check fittings to be sure they are tight. Use a compatible liquid thread sealant on male threads. Tighten fluid inlet and outlet fittings securely.
3. Place the suction tube (if used) in fluid to be pumped.

**NOTE:** If fluid inlet pressure to the pump is more than 25% of outlet working pressure, the ball check valves will not close fast enough, resulting in inefficient pump operation.

4. Place the end of the fluid hose into an appropriate container.
5. Close the fluid drain valve.
6. Back out the air regulator knob, and open all bleed-type master air valves.
7. If the fluid hose has a dispensing device, hold it open.
8. *Pumps with runaway protection:* Enable the prime/flush function by pushing the prime/flush button on the DataTrak.
9. Slowly increase air pressure with the air regulator until the pump starts to cycle. Allow the pump to cycle slowly until all air is pushed out of the lines and the pump is primed.

10. If you are flushing, run the pump long enough to thoroughly clean the pump and hoses.
11. Close the dispensing valve, if used.
12. Close the bleed-type master air valve.
13. *Pumps with runaway protection:* Disable the prime/flush function by pushing the prime/flush button on the DataTrak.

## DataTrak Operation

See DataTrak manual 313840 for all DataTrak information and parts, including detailed operation instructions.

## Pump Shutdown



At the end of the work shift and before you check, adjust, clean or repair the system, follow **Pressure Relief Procedure**, page 14.

# Maintenance

## Maintenance Schedule

Establish a preventive maintenance schedule, based on the pump's service history. Scheduled maintenance is especially important to prevent spills or leakage due to diaphragm failure.

## Lubrication

The pump is lubricated at the factory. It is designed to require no further lubrication for the life of the pump.

## Flushing and Storage



- Flush before fluid can dry in the equipment, at the end of the day, before storing, and before repairing equipment.
- Flush at the lowest pressure possible. Check connectors for leaks and tighten as necessary.
- Flush with a fluid that is compatible with the fluid being dispensed and the equipment wetted parts.

Flush the pump often enough to prevent the fluid you are pumping from drying or freezing in the pump and damaging it. Use a compatible solvent.

Always flush the pump and relieve the pressure before storing it for any length of time.

## Torque Instructions

**NOTE:** Fluid cover and manifold fasteners have a thread-locking adhesive patch applied to the threads. If this patch is excessively worn, the fasteners may loosen during operation. Replace screws with new ones or apply medium-strength (blue) Loctite or equivalent to the threads.

If fluid cover or manifold fasteners have been loosened, it is important to torque them using the following procedure to improve sealing.

**NOTE:** Always completely torque fluid covers before torquing manifolds.

Start all fluid cover screws a few turns. Then turn down each screw just until head contacts cover. Then turn each screw by 1/2 turn or less working in a crisscross pattern until each screw is torqued to 100 in-lb (11.3 N•m). Repeat for manifolds. See FIG. 7.

Retorque the air valve fasteners (V) in a crisscross pattern to specified torque.

**Plastic center sections:** 55 in-lb (6.2 N•m)  
**Metal center sections:** 80 in-lb (9.0 N•m)

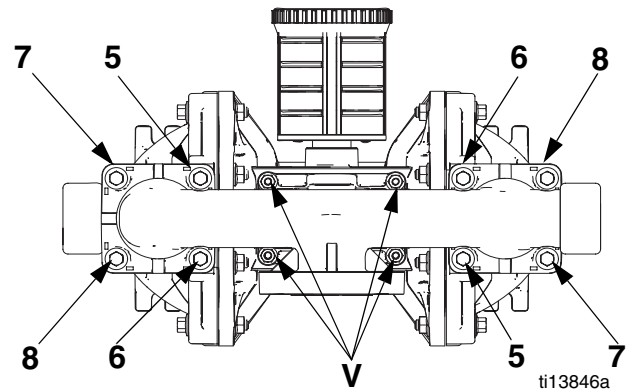
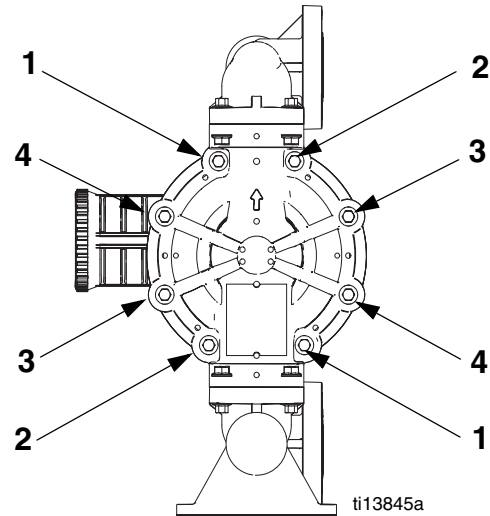

**FIG. 7. Torque sequence**





# Dimensions and Mounting

## Aluminum (1050A)

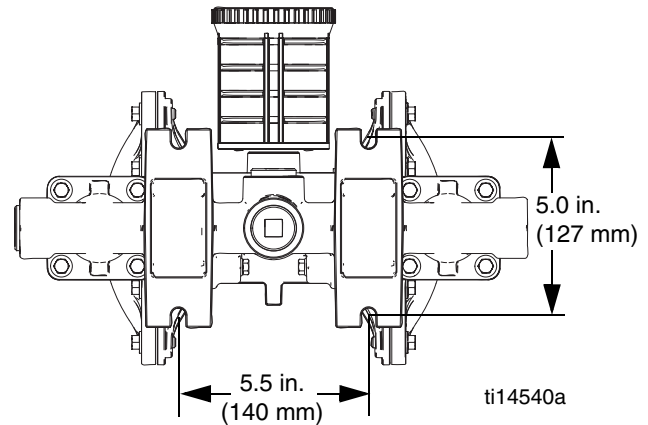
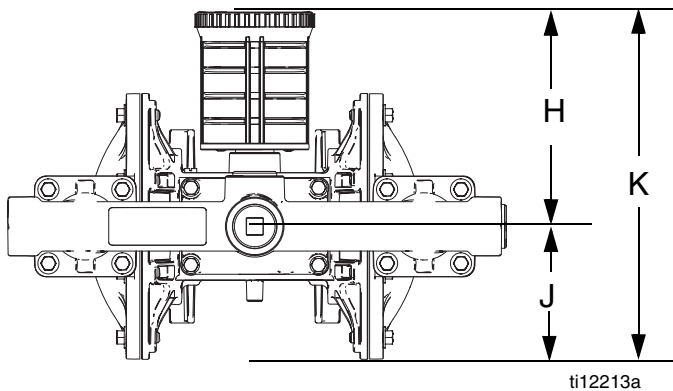
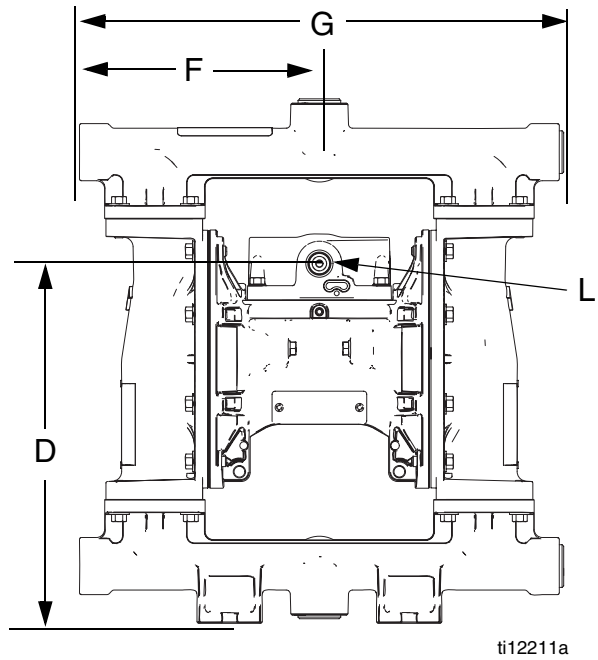
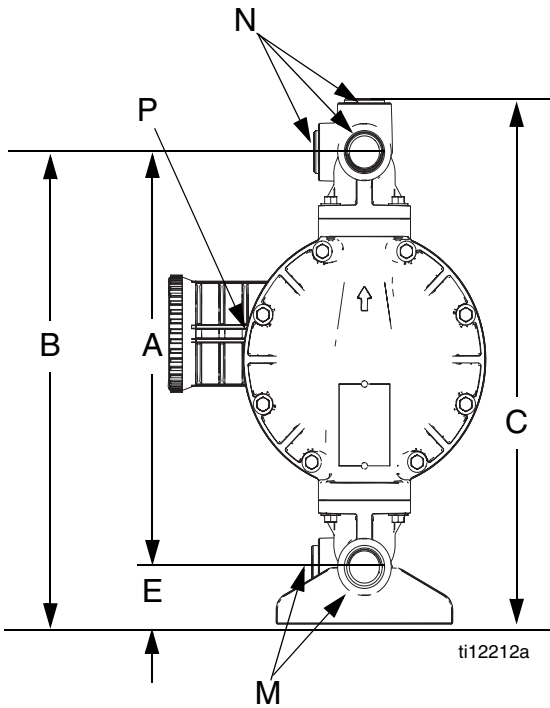

- A** ..... 12.7 in. (323 mm)
- B** ..... 14.4 in. (366 mm)
- C** ..... 15.9 in. (404 mm)
- D** ..... 10.9 in. (277 mm)
- E**..... 1.8 in. (46 mm)
- F**..... 7.3 in. (185 mm)
- G** ..... 14.7 in. (373 mm)
- H** ..... 6.1 in. (155 mm)

- J** ..... 3.9 in. (99 mm)
- K**..... 10.0 in. (254 mm)
- L**..... 1/2 npt(f) air inlet
- M** .... 1 in. npt(f) or 1 in. bspt fluid inlet ports (4)
- N**..... 1 in. npt(f) or 1 in. bspt fluid outlet ports (4)
- P**..... 3/4 npt(f) air exhaust port

## Polypropylene (1050P) and Conductive Polypropylene (1050C)

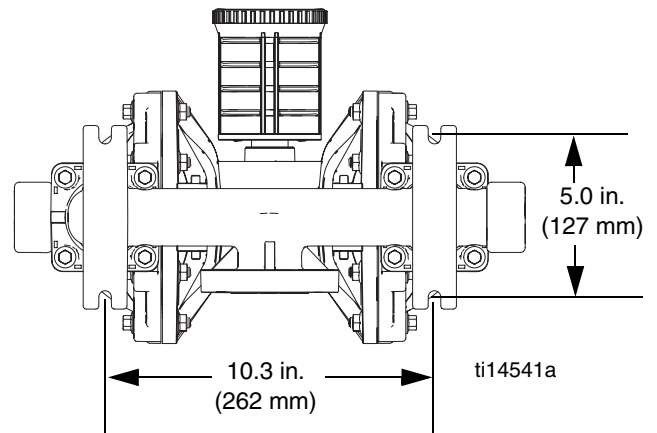
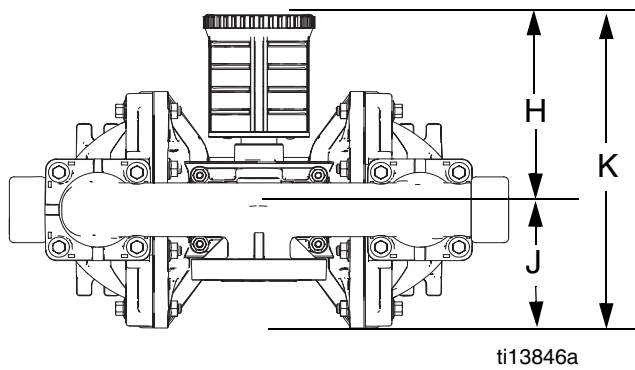
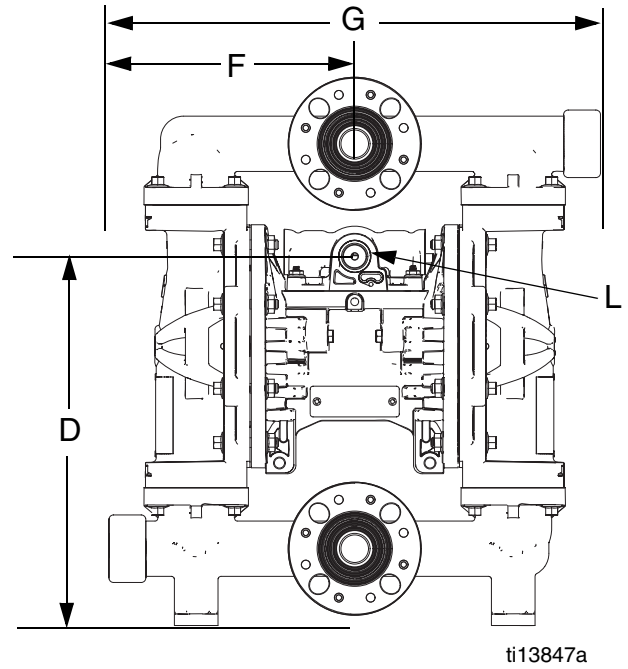
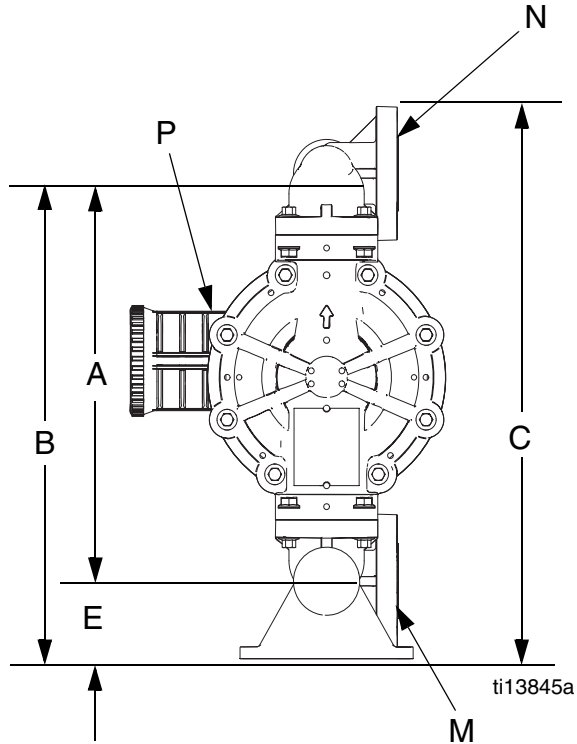

- A** ..... 13.2 in. (335 mm)
- B** ..... 15.7 in. (399 mm)
- C** ..... 17.8 in. (452 mm)
- D** ..... 12.0 in. (305 mm)
- E** ..... 2.5 in. (63.5 mm)
- F** ..... 8.0 in. (203 mm)
- G** ..... **Center Flange:** 16.0 in. (406 mm)  
**End Flange:** 15.2 in. (386 mm)
- H** ..... 5.6 in. (142 mm)

- J** ..... 3.9 in. (99 mm)
- K** ..... 9.6 in. (244 mm)
- L** ..... 1/2 npt(f) air inlet
- M** ..... 1 in. ANSI/DIN flange
- N** ..... 1 in. ANSI/DIN flange
- P** ..... 3/4 npt(f) air exhaust port

## Stainless Steel (1050S)

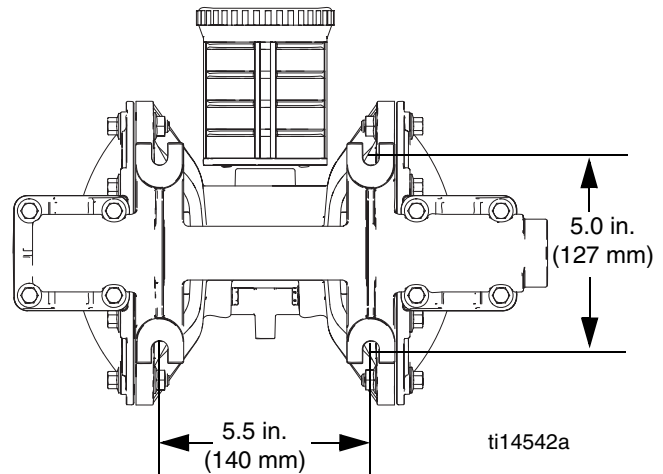
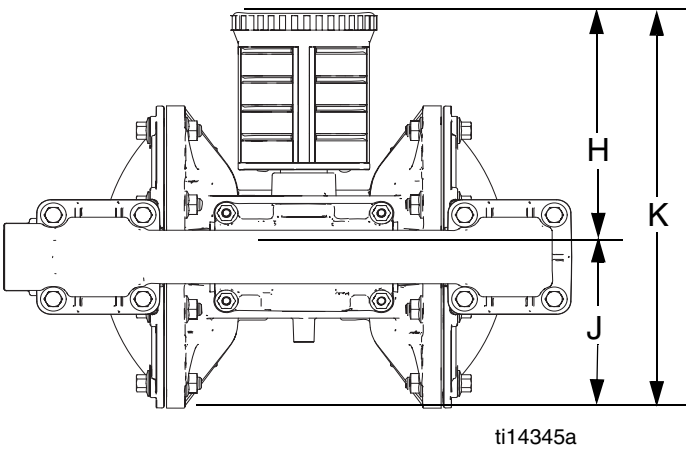
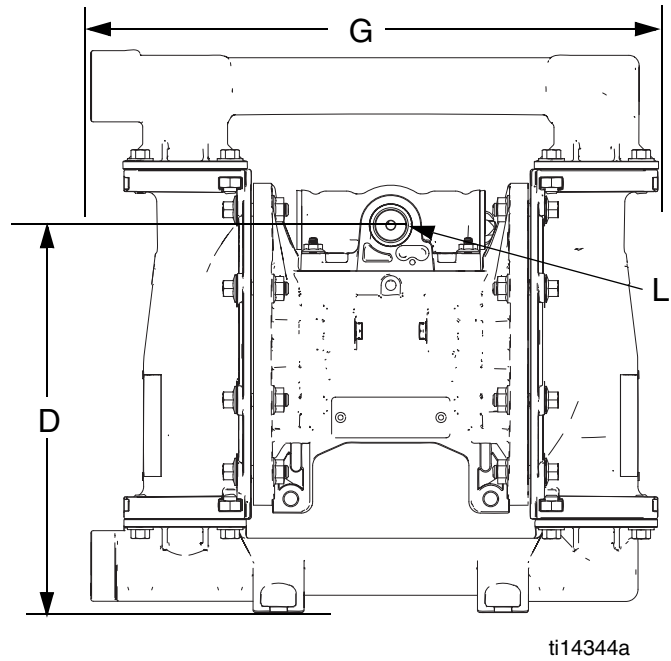
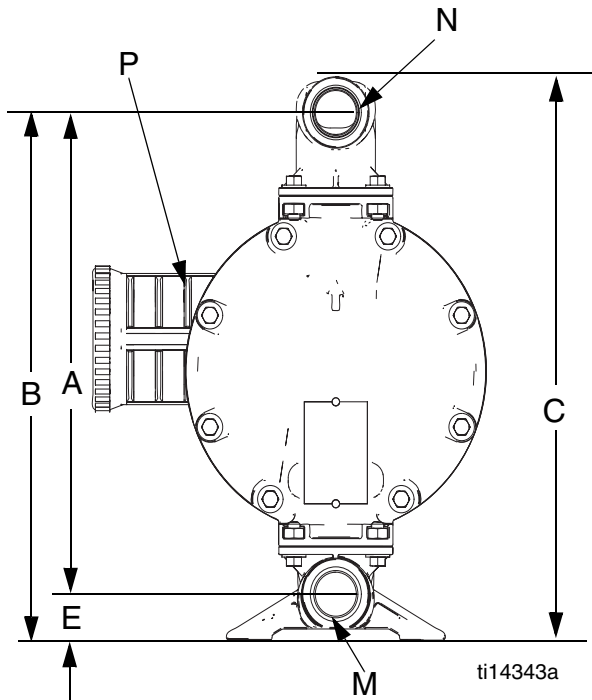

- A** ..... 11.8 in. (300 mm)
- B** ..... 12.9 in. (328 mm)
- C** ..... 13.7 in. (348 mm)
- D** ..... 9.5 in. (241 mm)
- E** ..... 1.1 in. (28 mm)
- G** ..... 13.9 in. (353 mm)
- H** ..... 5.7 in. (145 mm)
- J** ..... 4.0 in. (102 mm)
- K** ..... 9.6 in. (245 mm)

- L** ..... 1/2 npt(f) air inlet
- M** .... 1 in. npt(f) or 1 in. bspt fluid inlet ports (4)
- N** ..... 1 in. npt(f) or 1 in. bspt fluid outlet ports (4)
- P** ..... 3/4 npt(f) air exhaust port

# Performance Charts

**Test Conditions:** Pump tested in water with inlet submerged.

### Operating Air Pressure

- A**  
125 psi (0.83 MPa, 8.3 bar)
- B**  
100 psi (0.7 MPa, 7.0 bar)
- C**  
70 psi (0.48 MPa, 4.8 bar)
- D**  
40 psi (0.28 MPa, 2.8 bar)

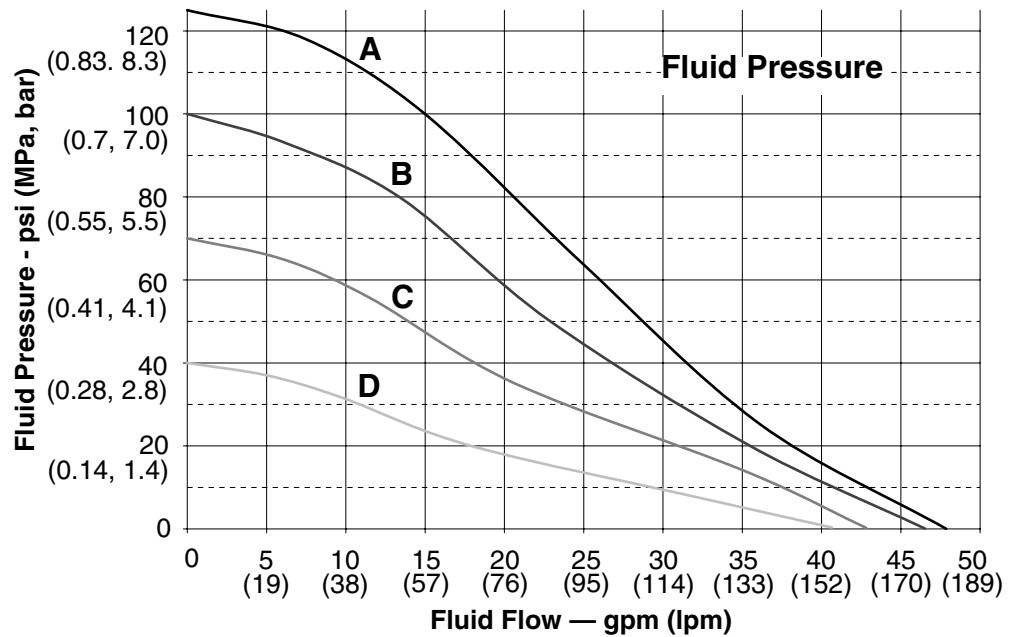

### How to Read the Charts

1. Locate fluid flow rate along bottom of chart.
2. Follow vertical line up to intersection with selected operating air pressure curve.
3. Follow left to scale to read **fluid outlet pressure** (top chart) or **air consumption** (bottom chart).

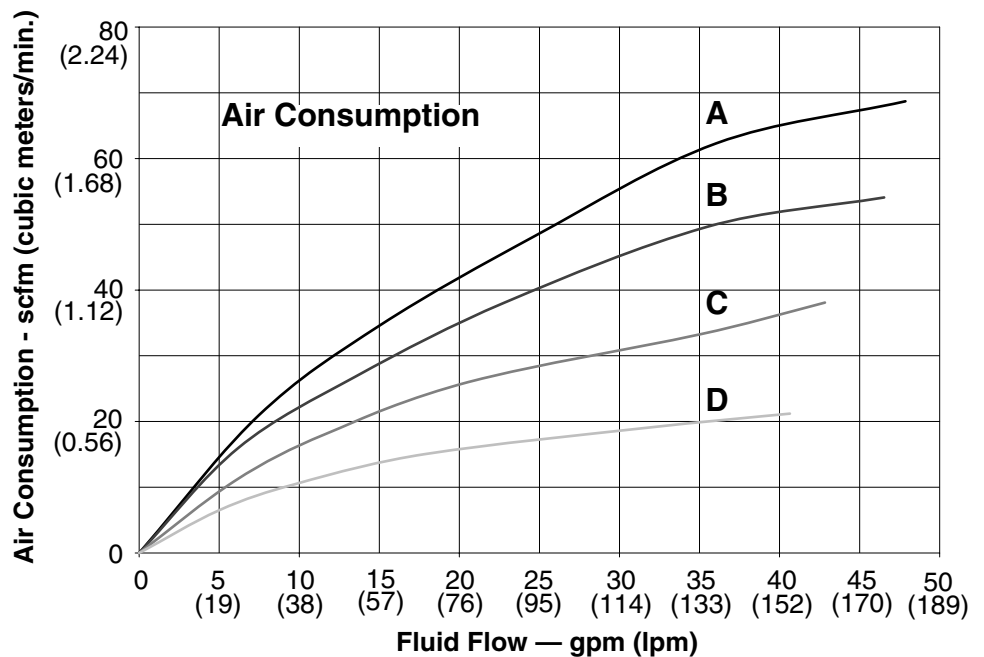

# Technical Data

Maximum fluid working pressure . . . . .	125 psi (0.86 MPa, 8.6 bar)
Air pressure operating range . . . . .	20-125 psi (0.14-0.86 MPa, 1.4-8.6 bar)
Maximum air consumption . . . . .	67 scfm
Air consumption at 70 psi (0.48 MPa, 4.8 bar),	
20 gpm (76 lpm) . . . . .	25 scfm
Maximum free-flow delivery . . . . .	50 gpm (189 lpm)
Maximum pump speed . . . . .	280 cpm
Fluid displacement per cycle . . . . .	0.17 gal. (0.64 liters)
Maximum suction lift . . . . .	16 ft (4.9 m) dry, 29 ft (8.8 m) wet
Maximum size pumpable solids . . . . .	1/8 in. (3.2 mm)
Sound Power*	
at 70 psi (0.48 MPa, 4.8 bar) and 50 cpm . . . . .	78 dBa
at 100 psi (0.7 MPa, 7.0 bar) and full flow . . . . .	90 dBa
Sound Pressure**	
at 70 psi (0.48 MPa, 4.8 bar) and 50 cpm . . . . .	84 dBa
at 100 psi (0.7 MPa, 7.0 bar) and full flow . . . . .	96 dBa
Operating temperature range . . . . .	see page 23
Air inlet size . . . . .	1/2 npt(f)
Fluid inlet size	
Aluminum (1050A) . . . . .	1 in. npt(f) or 1 in. bspt
Plastic (1050P and 1050C) . . . . .	1 in. raised face ANSI/DIN flange
Stainless Steel (1050S) . . . . .	1 in. npt(f) or 1 in. bspt
Fluid outlet size	
Aluminum (1050A) . . . . .	1 in. npt(f) or 1 in. bspt
Plastic (1050P and 1050C) . . . . .	1 in. raised face ANSI/DIN flange
Stainless Steel (1050S) . . . . .	1 in. npt(f) or 1 in. bspt
Weight	
Aluminum (1050A) . . . . .	23 lb. (10.5 kg)
Plastic (1050P and 1050C) . . . . .	18 lb. (8.2 kg)
Stainless Steel (1050S)	
with conductive polypropylene center . . . . .	36.3 lb. (16.5 kg)
with polypropylene center . . . . .	37.3 lb. (16.9 kg)
with aluminum center . . . . .	41.4 lb. (18.8 kg)
Wetted parts	
Aluminum (1050A) . . . . .	aluminum and material(s) chosen for seat, ball, and diaphragm options
Plastic (1050P and 1050C) . . . . .	polypropylene and material(s) chosen for seat, ball, and diaphragm options
Stainless Steel (1050S) . . . . .	stainless steel and material(s) chosen for seat, ball, and diaphragm options
Non-wetted external parts	
Aluminum (1050A) . . . . .	aluminum, coated carbon steel
Plastic (1050P and 1050C) . . . . .	stainless steel, polypropylene
Stainless Steel (1050S) . . . . .	stainless steel, polypropylene or aluminum (if used in center section)

\* Sound power measured per ISO-9614-2.

\*\* Sound pressure was tested 3.28 ft (1 m) from equipment.

All trademarks mentioned in this manual are the property of their respective owners.

## Operating Temperature Range

**NOTICE**

Temperature limits are based on mechanical stress only. Certain chemicals will further limit the maximum operating temperature range. Stay within the temperature range of the most-restricted wetted component. Operating at a temperature that is too high or too low for the components of your pump may cause equipment damage.

Diaphragm/Ball/Seat Material	Operating Temperature Range			
	Aluminum or Stainless Steel Pumps		Polypropylene or Conductive Polypropylene Pumps	
	Fahrenheit	Celsius	Fahrenheit	Celsius
Acetal (AC)	10° to 180°F	-12° to 82°C	32° to 180°F	0° to 82°C
Buna-N (BN)	10° to 180°F	-12° to 82°C	32° to 180°F	0° to 82°C
FKM Fluoroelastomer (FK)*	-40° to 275°F	-40° to 135°C	32° to 180°F	0° to 82°C
Geolast® (GE)	-40° to 150°F	-40° to 66°C	32° to 150°F	0° to 66°C
Neoprene overmolded diaphragm (CO) or Neoprene check balls (CR or CW)	0° to 180°F	-18° to 82°C	32° to 180°F	0° to 82°C
Polypropylene (PP)	32° to 180°F	0° to 82°C	32° to 180°F	0° to 82°C
PTFE overmolded diaphragm (PO)	40° to 180°F	4.0° to 82°C	40° to 180°F	4° to 82°C
PTFE check balls or two-piece PTFE/EPDM diaphragm (PT)	40° to 220°F	4° to 104°C	40° to 180°F	4° to 82°C
PVDF (PV)	10° to 225°F	-12° to 107°C	32° to 180°F	0° to 82°C
Santoprene® (SP)	-40° to 180°F	-40° to 82°C	32° to 180°F	0° to 82°C
TPE (TP)	-20° to 150°F	-29° to 66°C	32° to 150°F	0° to 66°C

\* The maximum temperature listed is based on the ATEX standard for T4 temperature classification. If you are operating in a non-explosive environment, FKM fluoroelastomer's maximum operating temperature in aluminum or stainless steel pumps is 320°F (160°C).

# Graco Standard Warranty

Graco warrants all equipment referenced in this document which is manufactured by Graco and bearing its name to be free from defects in material and workmanship on the date of sale to the original purchaser for use. With the exception of any special, extended, or limited warranty published by Graco, Graco will, for a period of twelve months from the date of sale, repair or replace any part of the equipment determined by Graco to be defective. This warranty applies only when the equipment is installed, operated and maintained in accordance with Graco's written recommendations.

This warranty does not cover, and Graco shall not be liable for general wear and tear, or any malfunction, damage or wear caused by faulty installation, misapplication, abrasion, corrosion, inadequate or improper maintenance, negligence, accident, tampering, or substitution of non-Graco component parts. Nor shall Graco be liable for malfunction, damage or wear caused by the incompatibility of Graco equipment with structures, accessories, equipment or materials not supplied by Graco, or the improper design, manufacture, installation, operation or maintenance of structures, accessories, equipment or materials not supplied by Graco.

This warranty is conditioned upon the prepaid return of the equipment claimed to be defective to an authorized Graco distributor for verification of the claimed defect. If the claimed defect is verified, Graco will repair or replace free of charge any defective parts. The equipment will be returned to the original purchaser transportation prepaid. If inspection of the equipment does not disclose any defect in material or workmanship, repairs will be made at a reasonable charge, which charges may include the costs of parts, labor, and transportation.

**THIS WARRANTY IS EXCLUSIVE, AND IS IN LIEU OF ANY OTHER WARRANTIES, EXPRESS OR IMPLIED, INCLUDING BUT NOT LIMITED TO WARRANTY OF MERCHANTABILITY OR WARRANTY OF FITNESS FOR A PARTICULAR PURPOSE.**

Graco's sole obligation and buyer's sole remedy for any breach of warranty shall be as set forth above. The buyer agrees that no other remedy (including, but not limited to, incidental or consequential damages for lost profits, lost sales, injury to person or property, or any other incidental or consequential loss) shall be available. Any action for breach of warranty must be brought within two (2) years of the date of sale.

**GRACO MAKES NO WARRANTY, AND DISCLAIMS ALL IMPLIED WARRANTIES OF MERCHANTABILITY AND FITNESS FOR A PARTICULAR PURPOSE, IN CONNECTION WITH ACCESSORIES, EQUIPMENT, MATERIALS OR COMPONENTS SOLD BUT NOT MANUFACTURED BY GRACO.** These items sold, but not manufactured by Graco (such as electric motors, switches, hose, etc.), are subject to the warranty, if any, of their manufacturer. Graco will provide purchaser with reasonable assistance in making any claim for breach of these warranties.

In no event will Graco be liable for indirect, incidental, special or consequential damages resulting from Graco supplying equipment hereunder, or the furnishing, performance, or use of any products or other goods sold hereto, whether due to a breach of contract, breach of warranty, the negligence of Graco, or otherwise.

## **FOR GRACO CANADA CUSTOMERS**

The Parties acknowledge that they have required that the present document, as well as all documents, notices and legal proceedings entered into, given or instituted pursuant hereto or relating directly or indirectly hereto, be drawn up in English. Les parties reconnaissent avoir convenu que la rédaction du présente document sera en Anglais, ainsi que tous documents, avis et procédures judiciaires exécutés, donnés ou intentés, à la suite de ou en rapport, directement ou indirectement, avec les procédures concernées.

# Graco Information

For the latest information about Graco products, visit [www.graco.com](http://www.graco.com).

**TO PLACE AN ORDER**, contact your Graco distributor or call to identify the nearest distributor.  
**Phone: 612-623-6921 or Toll Free: 1-800-328-0211 Fax: 612-378-3505**

*All written and visual data contained in this document reflects the latest product information available at the time of publication.  
Graco reserves the right to make changes at any time without notice.*

*This manual contains English. MM 312877*

**Graco Headquarters:** Minneapolis  
**International Offices:** Belgium, China, Japan, Korea

**GRACO INC. P.O. BOX 1441 MINNEAPOLIS, MN 55440-1441**

Copyright 2009, Graco Inc. is registered to ISO 9001

[www.graco.com](http://www.graco.com)